



Donaldson[®]
Filtration Solutions

ENGINE AIR CLEANERS, SERVICE PARTS AND ACCESSORIES

DONALDSON DELIVERS CLEAN AIR WHEN
YOUR ENGINE NEEDS IT MOST



Our innovative products are solving complex filtration challenges that improve people's lives, enhance engine and equipment performance and protect our environment.

Donaldson has the technical expertise, superior customer support and vast network of locations around the world to meet your toughest filtration needs - from initial system design through replacement products.



Improve



Enhance



Protect

Engine Air Cleaners, Accessories & Service Parts

Table of Contents

Introduction

| | |
|---------------------------------------|----|
| Invented by Donaldson | 2 |
| Our Customers | 8 |
| Warranty | 9 |
| Simple Facts on Air Filtration | 10 |
| Air Cleaner Models by Flow Direction | 12 |
| 5 Easy Steps to Air Cleaner Selection | 14 |
| Air Cleaner Selection Chart | 16 |
| Conversion Factors | 17 |

Air Cleaner Models

PowerCore® Series

| | |
|----------------------------|----|
| PSD (Medium to Heavy Dust) | 19 |
| PSD Service Instructions | 34 |

Light Dust

| | |
|-------------------------------|----|
| DuraLite™ ECB, ECC, ECD | 38 |
| DuraLite Service Instructions | 42 |
| EPB-ERB2 | 43 |
| EPB-ERB2 Service Instructions | 48 |

Medium Dust

| | |
|--|----|
| FKB | 50 |
| FKB Service Instructions | 54 |
| XRБ | 55 |
| XRБ Service Instructions | 59 |
| EPB-ERB2 with Full-View Pre-Cleaner | 60 |
| EPB-ERB2 with TopSpin™ Pre-Cleaner | 62 |
| FPG | 64 |
| FPG Alexin™ | 70 |
| FPG + FPG Alexin™ Service Instructions | 76 |
| FPG + FPG Alexin™ Mounting Bands | 77 |
| FTG Cycloflow™ | 78 |
| FTG Service Instructions | 81 |
| FRG2 | 82 |
| FRG2 Service Instructions | 88 |

Heavy Dust

| | |
|-------------------------------------|-----|
| FLB | 90 |
| FLB Service Instructions | 92 |
| EPB-ERB2 with Donaspin™ Pre-Cleaner | 93 |
| EPB-ERB2 with Strata™ Pre-Cleaner | 95 |
| SPB2 | 97 |
| SRB | 100 |
| SPB2-SRB Service Instructions | 103 |
| SSG Donaclone™ | 104 |
| SSG Service Instructions | 110 |
| STG Donaclone™ | 111 |
| STG Service Instructions | 117 |

Accessories

| | |
|---------------------------------------|-----|
| Clamps, Worm-Drive Hose & T-Bolt | 120 |
| Clamps, SealClamps™ | 121 |
| Drop Down Tube Extension (Dust Dumpa) | 122 |
| Exhaust Ejectors | 124 |
| In-Line Check Valve | 126 |
| In-Line Separators | 127 |
| Moisture Skimmer & Eliminator | 128 |
| Mounting Bands, Metal | 129 |
| Pre-Cleaners, DonaSpin™ | 130 |
| Pre-Cleaners, Full-View | 131 |
| Pre-Cleaners, TopSpin™ | 132 |
| Rain Caps | 134 |
| Restriction Indicators | 135 |
| Rubber Elbows, Humps & Reducers | 137 |
| Silicone Charge Air Connectors | 140 |
| Vacuator™ Valves | 141 |

Maintenance And Servicing

| | |
|-----------------------|-----|
| Air Filter Cleaning | 144 |
| Air Filter Inspection | 145 |
| General Tips | 146 |

Service Parts

Parts Listing

For a variation or a custom designed intake system, please call your current supplier of Donaldson products.

Designed to Fit Manufactured to Perform



... solve complex filtration challenges that improve people's lives, enhance engine and equipment performance and protect our environment.

Ultra-Web® Nanofiber Filtration Technology

Donaldson has developed Ultra-Web media for usage in applications that operate in the highest level of protection.

Ultra-Web media, a web-like filtering layer applied over specially-formulated cellulose media, traps submicron contaminant on the surface of the filter. This surface loading

prevents the contaminant from dispersing throughout the media and substantially increases the filter's efficiency. In field test, filters using Ultra-Web technology hold up to five times more contaminant compared to cellulose air filters

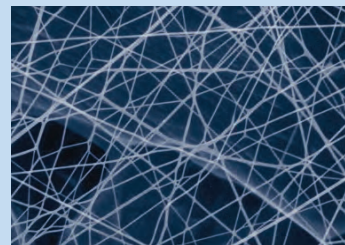

Scanning Electron Microscope image of Ultra-Web media magnified 1000 times.

Ultra-Web® Nanofiber Filtration Technology - a proven filter media with over 25 years in heavy-duty air filtration applications!

Over 90 million m² Ultra-Web media sold

Ultra-Web®
Nanofiber Filtration by Donaldson

Ultra-Web® and Cellulose Media at Same Magnification

Red circles represent the diameter of a 2 micron and a 5 micron particle. Cellulose media is used in most air filters.

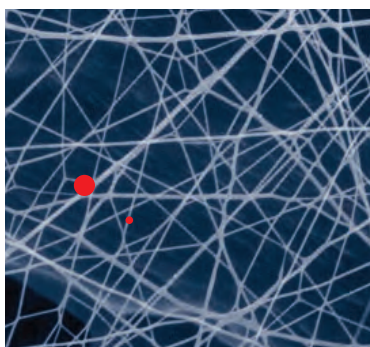

Ultra-Web fibers have submicron diameters and small interfiber spaces, which result in more contaminant being captured on the surface of the media and low restriction.

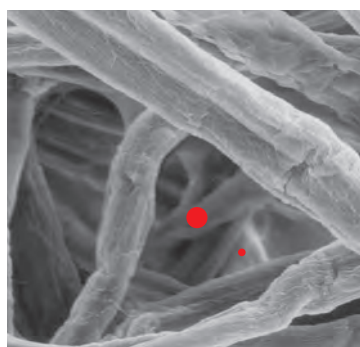

Cellulose fibers are larger than Ultra-Web fibers, and have larger spaces between the fibers, causing contaminant to load in the depth of the media and plug the airflow path; resulting in higher restriction and less capacity.



Designed to Fit Manufactured to Perform



... solve complex filtration challenges that improve people's lives, enhance engine and equipment performance and protect our environment.

PSD PowerCore® Air Cleaners, Peak performance in Half the Space

Air cleaners with original PowerCore filtration technology offer maximum design flexibility. You gain equal performance in significantly less space, freedom to design unique configurations to fit tight spots, and overall design simplicity.

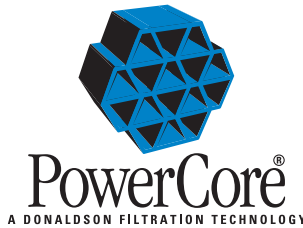

PSD08, PSD09, PSD10 and PSD12 housings

See the PSD PowerCore® air cleaner section for all the details.

PowerCore® G2 Filtration Technology Big Performance, Small Footprint

The second generation of Donaldson PowerCore Filtration Technology is now available for engine air intake systems. PowerCore G2 Filtration Technology offers size reduction and geometric flexibility to overcome the tight space constraints resulting from today's complex emissions systems. In addition to size reduction, its customizable filtration performance also features lower restriction and longer filter life. For more information on PowerCore G2, please contact your Donaldson representative.



A
Conventional
Cellulose Air Cleaner



B
Original
PowerCore® Air Cleaner



C
PowerCore G2
60% smaller than A
30% smaller than B

Designed to Fit Manufactured to Perform



... solve complex filtration challenges that improve people's lives, enhance engine and equipment performance and protect our environment.

RadialSeal™ Sealing Technology The best, most reliable choice for your engine

Filters using Donaldson RadialSeal Technology are lighter weight and easier to service than other filter designs. Invented by Donaldson in the 1980s, the urethane seal compresses radially on the outside surface of the outlet tube to create a seal around the tube.

In most applications, a safety element inside the main element seals radially to the inside of the outlet tube to provide an extra measure of protection. Filters equipped with RadialSeal Technology are easy to replace and provide leak-free seal even in adverse operating conditions such as extreme heat or cold.



XRB Air Cleaners Smaller, Lightweight Alternative Two-Stage Air Cleaner

The XRB family is ideal for light- to medium-duty diesel engine trucks, agriculture, construction, mining and industrial engine applications. The XRB air cleaner is smaller, lighter and easier to install and it effectively reduces contaminants, providing a high level of engine protection. Available in three diameter sizes.

See the XRB air cleaner section for all the details.



New XRB Housings: left XRB08; middle XRB12; and right XRB10 (filters shown from XRB12 model).

FKB Air Cleaners Smaller, Lightweight Alternative Two-Stage Air Cleaner

For smaller sizes of the XRB family, check out the FKB air cleaner family.

See the FKB air cleaner section for all the details.



FKB Housings and Filters: top center, FKB06; bottom left, FKB05; and bottom right, FKB04

Designed to Fit Manufactured to Perform

Invented by
Donaldson

... solve complex filtration challenges that improve people's lives, enhance engine and equipment performance and protect our environment.

Drop Down Tube Extension (Dust Dumpa) Replacement to Your Existing Dust Cup Assembly

Air cleaners operate in extreme dust conditions (mining, construction and quarrying). In some cases, the dust is so concentrated that maintenance personnel have to empty the dust cups or check the Vacuator™ Valves more frequently than they like.

These two new drop tube accessory incorporates rubber connections that improve dust evacuation from the housing during normal vehicle vibration. The clear tube allows you to easily see what's happening during daily inspections without climbing up to open or check out the Vacuator Valve.

Available for SSG and PSD PowerCore® air cleaner and also works on all other air cleaners with 76 mm drop tube. See the Accessories Section for more details.



New Dust Dumpa ship fully assembled.
Left: Part No. X006561 / Part No. X006562 right.



SSG



PSD

Go Twice the Distance with Donaldson Endurance™ Air Filters

Donaldson Endurance™ high efficiency air filters, made using Donaldson's advanced Ultra-Web® nanofiber technology, deliver cost saving benefits:

- Longer filter life with submicron contaminant
- Ideal for extended maintenance intervals
- Longer engine life
- Lower operating costs

Donaldson Endurance™ air filters are available for many popular Donaldson air cleaner housing models. Filters with Ultra-Web technology are easily recognized because of the blue filter media.

Finding a Donaldson Endurance air filter in this catalogue. If available for an air cleaner model, the Endurance air filters are listed in the service parts list with ES, Extended Service and HE, High Efficiency.



Designed to Fit Manufactured to Perform

Invented by
Donaldson

... solve complex filtration challenges that improve people's lives, enhance engine and equipment performance and protect our environment.

Don't forget Intake Accessories

Engine Air Accessories are designed to solve our customer's specific problems - such as excessive moisture or noise - or simply help maintain your systems.

- Inlet Hoods - protect air intake from large debris
- Pre-cleaners - extend air filter life and boost system efficiency
- Filter Gauges and Indicators - maximize filter life and reduce maintenance costs
- Rubber Elbows and Connectors - minimize air intake flow resistance, reduce noise levels in severe operating condition
- Vacuator™ Valves - automatically dispel dust and water from the air cleaner
- Stack Caps - protects the exhaust stack from water and debris.

See the Accessories Section for all the details.



Donaldson TopSpin™ Pre-Cleaner Extend Filter Life in Heavy Dust Conditions

We recently upgraded the cover material of the TopSpin Pre-Cleaner to **increase impact resistance**. Before it was a see-through unit, now it is **black**.

This new design will even more extend your primary air filter life, boost your system efficiency and extend your engine life!

Donaldson TopSpin requires no maintenance and works great on all types of equipment, from crawler tractors to farm tractors to skid steer loaders.

See the Accessories Section for all the details.



Designed to Fit Manufactured to Perform

Invented by
Donaldson

... solve complex filtration challenges that improve people's lives, enhance engine and equipment performance and protect our environment.

A New Generation of Hybrid Air Cleaners
featuring Donaldson's Unique Design Concept

**UNIQUE
DESIGN
CONCEPT**

Air Cleaners equipped with Donaldson's Unique Design Concept ensure you

1) The best protection for your Engine:

- Via a unique fit of the element into the access cover, rotation of the element is prevented which improves durability of the radial seal.
- The unique interface between the primary element and access cover assures best fit and function and is achieved only with the Donaldson original elements, discouraging use of low quality will-fit elements.
- New moulded polymer closed end cap works in conjunction with the element retention system resulting in outstanding durability and safer manipulation of your element.
- A plastic liner outer instead of a metal one prevents media pleat tip wear and improves handling protection.

2) The best protection for our Environment:

- Reduced metal content.

See the ERB2, FRG2 and SPB2 Air Cleaner Section for more details on these next generation products.

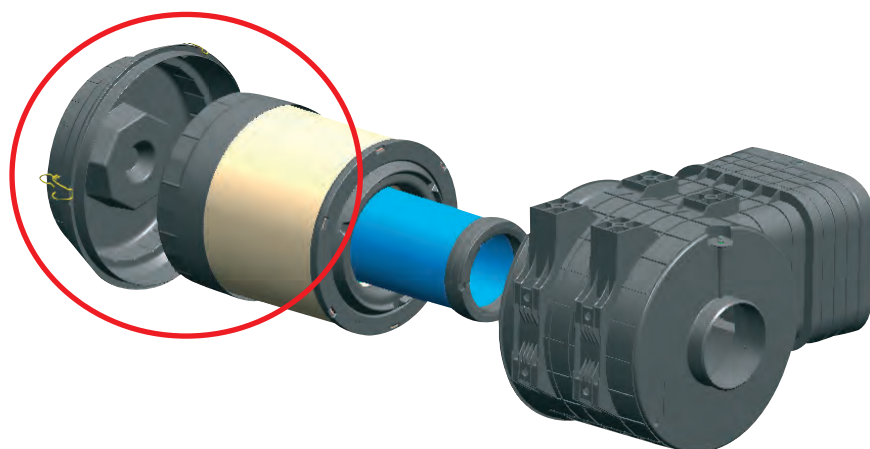

**Built with
Donaldson Technology.**

Designed to Fit Manufactured to Perform

**the following customers
rely on Donaldson**



Agco, Case New Holland, Claas, Deutz, Fendt,
John Deere, Landini, Manitou, Massey Ferguson,
McCormick, Renault Agriculture, SAME, Valtra...



BMC, Carrier Transicold, DAF, Daimler, EvoBus, FIAT,
Ford Otosan, Freightliner, International, Isuzu, Iveco, MAN,
Paccar, Renault Truck, Scania, Thermo-King,
Vanhool, VDL Bus, Volvo...



AtlasCopco, Bobcat, Case New Holland,
Daewoo, Doosan, Dynapac, Fermecc, Fiat-Kobelco,
Furukawa, Hitachi, JCB, Komatsu, Liebherr, Linde,
MCFE, Merlo, Sandvik, Terex, Toyota, Volvo CE...



Cummins, Detroit Diesel, Honda, Isuzu,
Iveco, John Deere, KHD, Komatsu, Kubota, MAN
Engines, Mercedes Benz, Perkins, Scania, Sisu,
Steyr Motors, Yanmar Diesel...



Manitou, Hyster, JCB, Jungheinrich,
Komatsu, Linde, Toyota...

Donaldson Engine Aftermarket Warranty for Filtration and Exhaust Products

Donaldson warrants its Aftermarket products against failure due to defects in materials and workmanship for the period specified under Terms and Conditions for the particular product.

Donaldson's obligation under this warranty covers replacing the failed product, including transportation charges, only. If the Donaldson product failure is the sole and direct cause of damage to the equipment on which the product was properly installed, Donaldson will reimburse reasonable costs to restore the equipment to the condition it was in immediately before the failure.

This warranty does not cover failure due to misapplication, misuse, abuse, neglect, rust through and corrosion (mufflers), improper service practices or non-Donaldson approved modifications. Engine and equipment manufacturers' warranties remain in effect when Donaldson products are used.

Donaldson must be notified in writing of any claims covered by this warranty within one year of the date of failure. Donaldson, at its discretion, will either physically visit the site where the alleged failure has been found or, request that all parts, Donaldson and other relevant parts, be shipped prepaid to its General Office, in care of the Product Lab or as otherwise specified.

Terms & Conditions

Warranty coverage begins at the date of installation to the original end-user, and expires after the indicated period or kilometres, whichever occurs first.

More detailed information can be found in the Donaldson Europe Operating Guide or can be received upon request.

Warranty Length by Product

Filtration Products

Air Cleaner Housing & Accessories
Liquid Filter Assemblies & Accessories
Air & Liquid Filters

Warranty Period

1 year
1 year
Maximum 1 year

Exhaust Products

Exhaust Assemblies On-Road
Exhaust Assemblies Off-Road
Exhaust Accessories

Warranty Period

2 years - 300.000 kilometers
1 year - 1500 working hours
1 year

Brochure No. F116006 (11/08)

Simple Facts on Air Filtration

... common terms and definitions.

Why an Air Intake System?

Air is a critical component of combustion for a diesel engine. If the air reaching the engine is not clean, the engine will lose efficiency and have engine wear. The engine will run longer and more efficiently with a proper air intake system that is designed to keep the engine intake air as clean as possible by removing particulate matter or debris that would cause engine wear and ultimately failure.

Components Air Intake System

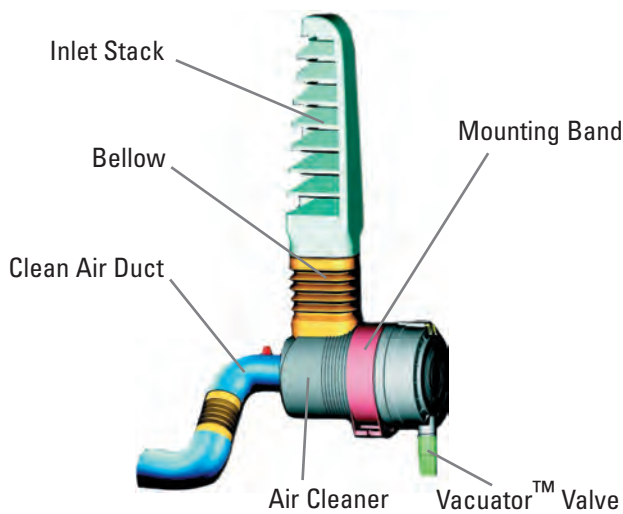

Air Cleaner Types

One-Stage Air Cleaners

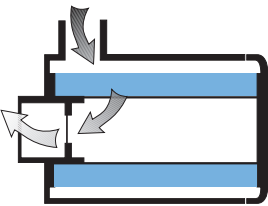

Air Cleaners in which the air goes through the inlet and directly to the main element are considered one-stage air cleaners. One-stage air cleaners are typically used where there is less contaminate in the environment, such as in on-road applications.

Two-stage Air Cleaners

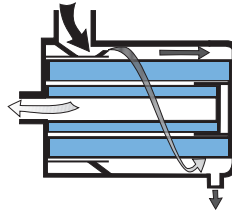

Air entering a two-stage air cleaner is first pre-cleaned before reaching the main element. The air may either be sent through pre-cleaner tubes or cleaned by centrifugal flow around the filter. Depending on the type of pre-cleaner, the pre-cleaner removes between 75-98% of the contaminate from the air before the air reaches the main element. Two stage air cleaners are recommended for use in medium- and heavy dust environments, such as in agricultural, construction, and mining applications.

Element types

Main Element

Is the filter element in the air cleaner that removes around 99,9%+ of the air's dust. The air flows through the main element first.

Safety Element

Is an optional element that protects the engine during servicing of the main element and in case of a leak in the main element.

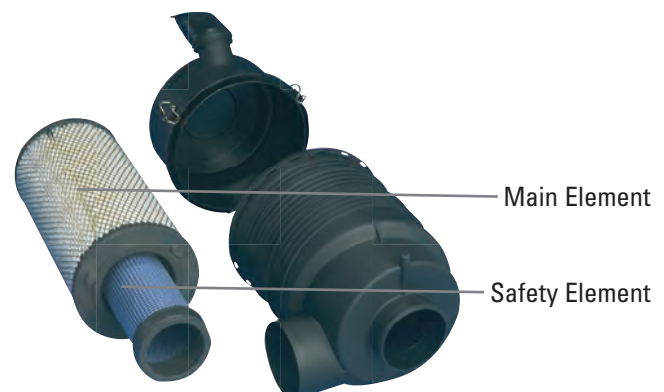

Simple Facts on Air Filtration

... common terms and definitions.

Technologies

RadialSeal™

RadialSeal refers to Donaldsons sealing technology, which uses the urethane end caps and the cleaners outlet tube to create the seal. This is the preferred method of sealing.



Axial Seal

The Axial Seal sealing method requires a force between air filter and air cleaner that provides enough compression on the gasket between the parts to create a seal.



Filtration Terms

Dust Capacity

Dust capacity is the amount of contaminant that will be collected on a filter before final restriction level - as set by the engine manufacturer - is reached.

Efficiency

Efficiency is the percentage of dust that the air cleaner with a filter removed from intake air. Donaldson air cleaners have a 99,7% efficiency level.

Restriction

Restriction represents the resistance to the flow of air through the air cleaner system. Typical unit is kilopascal (kPa). Air cleaners with clean filters should have restrictions between 0,5 and 4 kPa.

Filter media

Filter media is the material in the filter that removes the contaminate. Conventional media is made from cellulose fibers combined with resins to keep the fibers together.



Dust Concentration

Dust concentration expresses the mass of dust in a specified volume of air. Typical ambient conditions are around 0,1 milligrams per cubic meter (mg/m^3). Dirt road conditions are around 10 milligrams per cubic meter (mg/m^3).

Laboratory Life

This is the life of an air filter, until a defined restriction, tested at a constant dust concentration (mg/m^3) following an ISO 5011 laboratory test procedure to determine performance and allow comparison with other air filter models.

Field Life

This is the life of an air filter, till a defined final restriction, during its usage in the field.

Differential Pressure

The difference in pressure between two points, generally between the inlet and outlet of an air cleaner. To be measured in pascal (Pa).

Pascal

The SI unit to express a pressure, to be used instead of mm H₂O.

Pa (pascal) - kPa (kilopascal) - mbar (millibar) - daPa (decapascal)

| | |
|-----------------------|--------------|
| 1 mm H ₂ O | = 9,80665 Pa |
| 1000 Pa | = 1 kPa |
| 100 Pa | = 1 mbar |
| 10 Pa | = 1 daPa |

Airflow Requirements

Air is as critical to the operation of an engine as it is to the working of the human body. Like lungs, an engine draws air from the atmosphere. The amount of air required by engine depends on the type of engine, whether there is a turbocharger, and the amount of horsepower of the engine. The airflow requirement is a specification of the engine that should be given by the engine manufacturer.

Air Cleaner Selection by Flow Direction

Donaldson has air cleaner housings that work in a variety of dust conditions and air flow patterns (A - D, and G). For improved filtration reliability and quicker filter service compared to older axial seal style air cleaners, Donaldson recommends installing either PowerCore air cleaners or radial seal style air cleaners whenever possible.

Flow Direction Legend

B = Air in the Side, Out the End

C = Air in the End, Out the Same End

D = Air in the End, Out the Opposite End

G = Air in the Side, Out the End

B Airflow

Air in the Side, Out the End

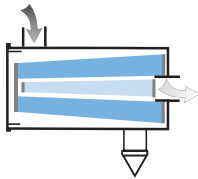

Light and Medium Dust - FKB

A compact housing high dust holding capacity, and comparable airflow to FPG. Two-stage filtration, side inlet, horizontal installation. Body diameters in 4", 5" and 6". Mount under hood or behind cab. Handles airflows from 2-6 m³/min. Used on off-road equipment operating in medium-dust conditions. Page 50-54.

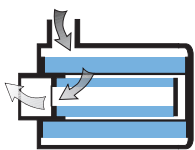

Light, Medium & Heavy Dust - EPB

One-stage full-plastic air cleaner. Body diameters in 7" and 8". Handles airflows of 2-7 m³/min. Used on light-, medium- and heavy-duty applications, always combined with a pre-cleaner. Page 43-48.

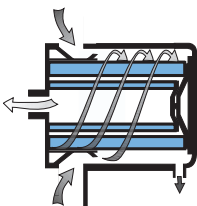

Heavy Dust - FLB

Two-stage air cleaner with scavange exhaust system. Body diameters in 6", 8", 10" and 12". Handles airflows of 3-17 m³/min. Designed for heavy-duty equipment. To be used with an exhaust ejector. Page 90-92.

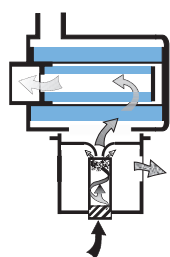

Heavy Dust - SRB

Two-stage hybrid air cleaner with built-in high efficiency pre-cleaner. Body diameters in 9", 10", 11" and 13". Handles airflows of 4-18 m³/min. Designed for heavy-duty equipment. To be used with an exhaust ejector. Page 100-103.

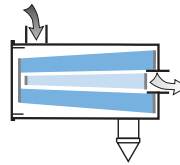

Medium Dust - XRB

The radial seal, plastic, two-stage air cleaner. with side inlet for horizontal installation. Body diameters in 8", 10" and 12". Mount under hood or behind cab. Handles airflows of 7.5-18 m³/min. Used on off-road equipment operating in medium-dust conditions. Page 55-59.



Heavy Dust - SPB2

Two-stage full-plastic air cleaner with built-in high efficiency pre-cleaner. Body diameter of 13". Handles airflows of 6-22 m³/min. Designed for heavy-duty equipment. To be used with an exhaust ejector. Page 97-99.

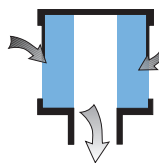

Light Dust - ECB

Disposable, one-stage, dry air cleaner, small, lightweight and unitized (housing and filter in one). For 2-3 cylinder, high-vibration engines. Can be vertically or horizontally mounted. Handles airflows of 6-90 m³/min. Used on light-duty applications. Page 38-42.

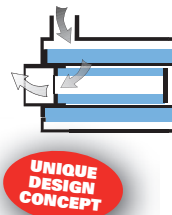

Light, Medium & Heavy Dust - ERB2

One-stage hybrid air cleaner. Body diameters in 10", 11", 13" and 15". Handles airflows of 8-65 m³/min. Used on light-, medium- and heavy-duty applications, always combined with a pre-cleaner. Page 43-48.

C Airflow

Air in the End, Out the Same End

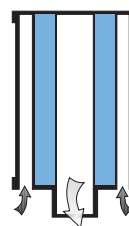

Light Dust - ECC

Disposable, one-stage, dry air cleaner, small, lightweight and unitized (housing and filter in one). For small 2-3 cylinder, high-vibration engines. Can be vertically or horizontally mounted. Handles airflows of 1-26.5 m³/min. Used on off-road equipment operating in medium-dust conditions. Page 38-42.

D Airflow

Air in the End, Out the Opposite End

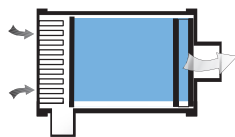

Medium to Heavy Dust - PSD

Two-stage air cleaner with built-in high efficiency pre-cleaner using the PowerCore™ Filtration Technology. Smaller, compact with built-in mounting brackets. Can be vertically or horizontally mounted. Handles airflows of 6-30 m³/min. Body diameters in 8", 9", 10" and 12". Designed for medium- and heavy-duty equipment. Can be used with Vacuator™ Valve on the pre-cleaner or continuously scavenge of the pre-cleaner by an exhaust ejector or air blower cooling. Page 19-35.

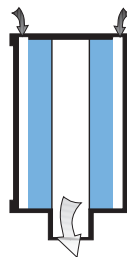

Light Dust - ECD

Disposable, one-stage, dry air cleaner, small, lightweight and unitized (housing and filter in one). For small 2-3 cylinder, high-vibration engines. Can be vertically or horizontally mounted. Handles airflows of 1-23 m³/min. Used on light-duty applications. Page 38-42.

G Airflow

Air in the Side, Out the End

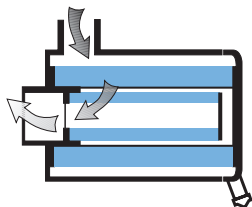

Medium Dust - FPG

The first fully plastic air cleaner in our two-stage filtration line. Built-in pre-cleaner. Tangential inlet, with or without safety element, body diameters from 4", 5", 7", 8" and 10". Handles airflows of 0.5-12 m³/min. Can be mounted horizontal, vertical or at an angle. Used on medium-duty applications. Page 64-69 / 76-77.

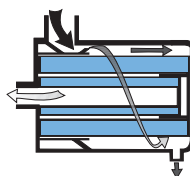

Medium to Heavy Dust - FTG

Two-stage air cleaner with built-in pre-cleaner. Body diameter of 21". Handles airflows of 32-59 m³/min. Used in medium- to heavy-duty duty applications. Page 78-81.

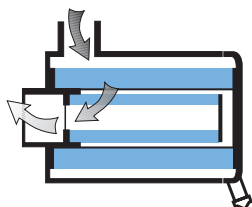

Medium Dust - Alexin FPG

Two-stage full-plastic air cleaner with built-in pre-cleaners. Tangential inlet, with or without safety element, body diameters from 6", 8", 9" and 10". Handles airflows of 1.5-12 m³/min. Can be mounted horizontal, vertical or at an angle. Used on medium-duty applications. Page 70-77.

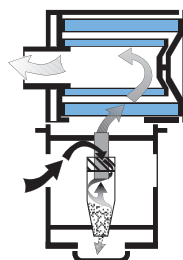

Heavy (Severe) Dust - SSG

These new models are replacing our older SRG models. Donaldson's largest two-stage engine air cleaner, designed for the engines on large equipment. Handles airflows of 48-135 m³/min. The best protection for 500 to 2000 horsepower diesel engines. This new model uses radial seal sealing technology for filter retention. Used on heavy-duty applications. Page 104-110.

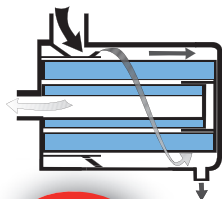

Medium to Heavy Dust - FRG2

Two-stage hybrid air cleaner which is available in body diameters of 10", 11", 13", 15" and 18". Horizontal mount required. Handles airflows from 6.5-51 m³/min. Used in medium- to heavy-duty duty applications. Page 82-88.

UNIQUE DESIGN CONCEPT

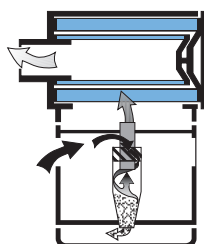

Heavy (Severe) Dust - STG

Two-stage - high airflow - air cleaner with built-in Donaclone™ tube pre-cleaner. Two styles available - one with a peripheral inlet and another with a tubular inlet. Handles airflows from 11-50 m³/min. Can be mounted vertically or horizontally. Used on heavy-duty applications. Page 111-117.

Five Easy Steps to Air Cleaner Selection

(1) Determine the Airflow Requirements of the Engine

There are 2 different formulas to estimate the airflow (m^3/min) required by the engine.

One formula is based on Engine Displacement (Formula A). The other is based on Engine Horse Power (Formula B).

$$\text{Formula A} = \text{Airflow} = \frac{\text{Engine Displacement} \times \text{RPM} \times \text{VE}}{1000 \times \text{CF}} = \text{m}^3/\text{min}.$$

- **Engine Displacement**
Size of the engine expressed in litres (swept volume).
- **RPM = Revolutions per minute**
- **VE = Volumetric Efficiency**

VE Table

0,85 for 4 stroke natural aspirated diesel engine
1,60 for 4 stroke turbo charged diesel engine
1,85 for 4 stroke turbo charged after cooled diesel engine
1,40 for 2 stroke scavenge blower diesel engine
1,90 for 2 stroke turbo charged diesel engine

- **CF = Cycle Factor = 2 for 4 stroke engine**
1 for 2 stroke engine

$$\text{Formula B} = \text{Airflow} = \frac{\text{HP(SAE)} \times \text{SA}}{1000} = \text{m}^3/\text{min}.$$

- **HP(SAE) = Horse Power**
- **SA = Specific Airflow per Horse Power**

SA Table

0,057 m^3/min . for 4 stroke natural aspirated diesel engine
0,065 m^3/min . for 4 stroke turbo charged/after cooled engine
0,093 m^3/min . for 2 stroke scavenge blower diesel engine
0,102 m^3/min . in for 2 stroke turbo charged diesel engine

Additional Consideration

1. Please be aware that when you have High Pulsation engines the air inflow to the air cleaner is influenced by this pulsation. We recommend that you review the application and if necessary multiply the airflow - found by one of above formula - by the pulsation factor (PF).

PF Table

2,1 for 1 cylinder engine natural aspirated.
1,5 for 2 cylinder engine natural aspirated.
1,2 for 3 cylinder engine natural aspirated.
1,0 for 4 and more cylinder engine natural aspirated.

2. No pulsation factor needs to be considered for turbo charged engines.
3. Donaldson ECB, ECC, ECD Duralite™ (see page 38-42) and the FPG057505 Air Cleaners (see page 67) are not subject to the pulsation factor due to the fact that we use a specially developed High Pulsation media for these products.

Example

A tractor is equipped with a 40 HP(SAE), 3 cylinder, 4 stroke natural aspirated diesel engine of 2 litres running at 2600 RPM.

$$\text{Formula A} = \text{Airflow} = \frac{2 \times 2600 \times 0,85}{1000 \times 2} = 2,21 \text{ m}^3/\text{min}.$$

$$\text{Formula B} = \text{Airflow} = 40 \times 0,057 = 2,28 \text{ m}^3/\text{min}.$$

In High Pulsation application multiply your answer by PF table which in this case is $2,21 \text{ m}^3/\text{min} \times 1,2 = 2,652 \text{ m}^3/\text{min}$.

Five Easy Steps to Air Cleaner Selection

(2) Determine the Type of Machine and its Environment

For example, a truck of less than 8 ton will probably see light-dust, whereas dumpers used on construction sites would almost always be surrounded by an extremely heavy-dust concentration of large dirt particles. To determine the type of environment and the dust concentration level your machine works in, you can use the table below.

| Environment | Applications | Dust concentration (mg/m ³) |
|--|---|---|
| Light-Duty (On-Road, Marine) | On-Highway Trucks (< 8T), Lift Truck, Pumps for use in generators, compressors, marine, small engines and railroad. | 1-5 + carbon, soot, oil vapour |
| Medium-Duty (Light Construction, Agricultural, Compressors) | Mixed operating Trucks (8 - 16T), Farm Tractor, Lift Truck, Mobile Compressor, Skid Steer. | 5-15 |
| Medium- to Heavy-Duty | Combines and Harvesters, Earth Moving Equipment, Loader, Dozer, Grader, Excavator, Artic Dumper. | 15-20 |
| Heavy-Duty (Construction, Mining) | Scraper, Dumper, Track type dozer, Mining Equipment, Rail Road (Middle East). | 20-50 |
| Extra Heavy-Duty | Special equipment, Military. | 50-100 |

Note: These figures are only indications.

(3) Select an Air Cleaner Series

You can do this by using the Air Cleaner Selection Overview on page 12-13. This correlates the Airflow Requirements of your engine (which you calculated under step 1) with the Dust Concentration level of your environment (which you calculated under step 2).

(4) Choose a SPECIFIC Air Cleaner Model

Once you have selected your Air Cleaner Series you can look in the catalogue for the specific Air Cleaner Model according to the Air Flow Requirements your engine needs. You can do this by referring to the Air Flow Restriction Curves. If there are 2 air cleaner models that fit your parameters, choose the one with the lowest restriction to ensure maximum service life from that air cleaner series.

(5) Choose Intake Accessories

Accessories are an integral and important part of the entire air intake filtration system. See the Accessories Section for more details.

Engine Protection for All Dust Conditions

...Donaldson offers a full line of air cleaners for a wide variety of applications and operating environments

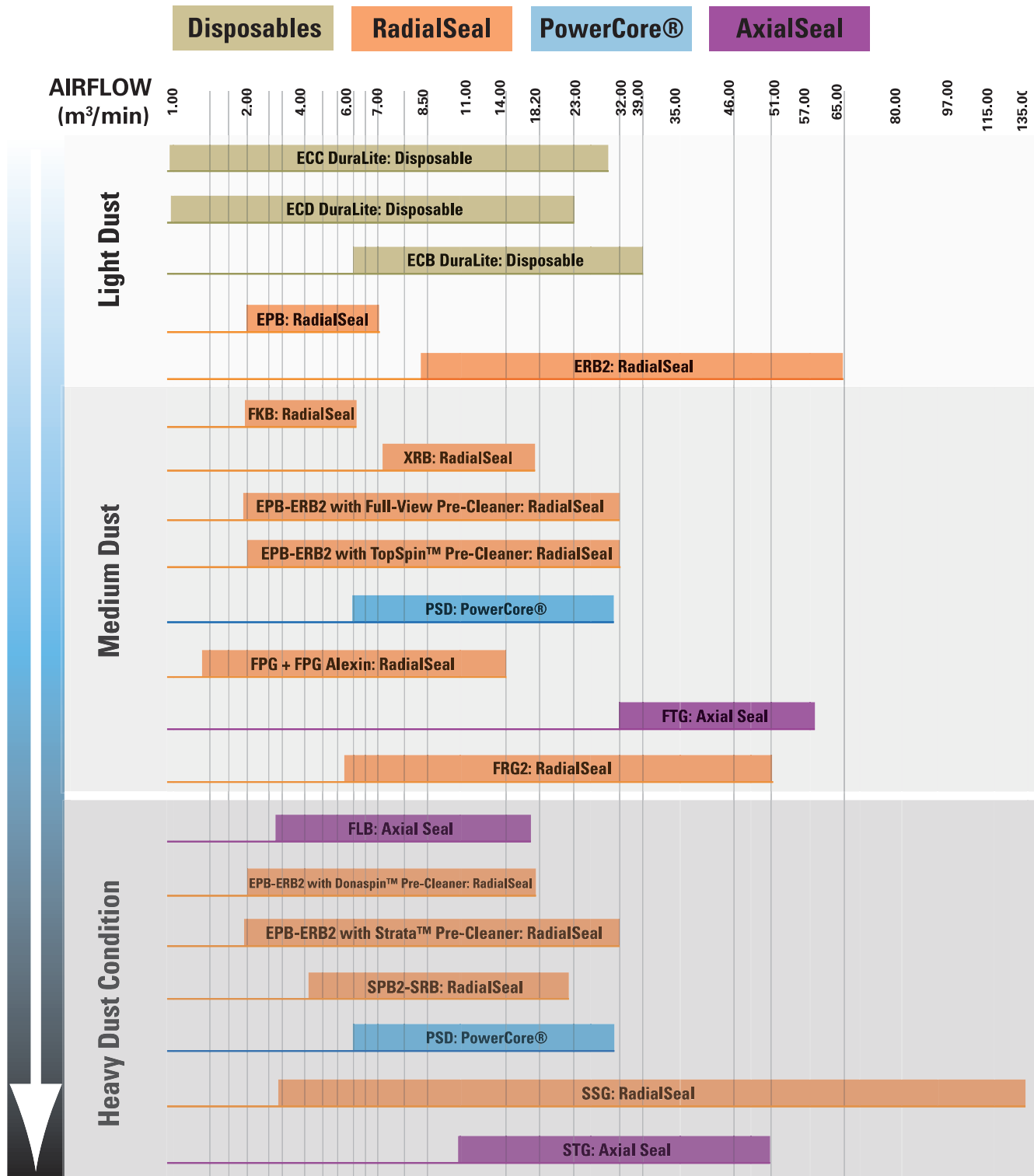

Air Filtration Conversion Factors

Temperature

$$^{\circ}\text{C} = (^{\circ}\text{F} - 32) \times 5/9$$

$$^{\circ}\text{F} = (^{\circ}\text{C} \times 9/5) + 32$$

Power

$$\text{HP} = \text{KW} \times 1,341 \text{ (metric)}$$

$$\text{KW} = \text{HP} \times 0,745 \text{ (metric)}$$

Flow rates

$$1 \text{ l/min.} = 0,0353 \text{ cfm}$$

$$1 \text{ m}^3/\text{min.} = 35,3147 \text{ cfm}$$

$$1 \text{ m}^3/\text{h} = 0,5886 \text{ cfm}$$

$$1 \text{ English gallon/min.} = 0,1605 \text{ cfm}$$

Length

$$1 \text{ m} = 1000 \text{ mm} = 39,37 \text{ inch} = 3,281 \text{ ft.}$$

$$1 \text{ inch} = 25,4 \text{ mm} = 0,0254 \text{ m} = 0,08333 \text{ ft.}$$

$$1 \text{ ft.} = 304,8 \text{ mm} = 0,3048 \text{ m} = 12 \text{ inch}$$

Volume

$$1 \text{ m}^3 = 1000 \text{ litres} = 35,31 \text{ ft.}^3 = 61024 \text{ inch}^3$$

$$1 \text{ ft.}^3 = 28,32 \text{ litres} = 0,02832 \text{ m}^3 = 1728 \text{ inch}^3$$

$$1 \text{ litre} = 0,2642 \text{ US gallon} = 0,2201 \text{ Engl gallon}$$

$$1 \text{ US gallon} = 3,785 \text{ litres} = 231 \text{ inch}^3$$

$$1 \text{ English gallon} = 4,546 \text{ litres} = 277 \text{ inch}^3$$

Weight

$$1 \text{ kg} = 2,205 \text{ lb} = 35,27 \text{ Oz}$$

$$1 \text{ lb} = 0,4536 \text{ kg} = 16 \text{ Oz}$$

$$1 \text{ Oz} = 0,02835 \text{ kg} = 0,0625 \text{ lb}$$

Pressure

$$1 \text{ mm H}_2\text{O} = 9,80665 \text{ Pa}$$

$$1 \text{ bar} = 100 \text{ kPa} = 14,5 \text{ psi}$$

$$10 \text{ mbar} = 1 \text{ kPa} = 0,145 \text{ psi}$$

$$10 \text{ psi} = 68,95 \text{ kPa} = 0,6895 \text{ bar}$$

$$1 \text{ "Hg} = 345,4 \text{ mm H}_2\text{O} = 3,321 \text{ kPa}$$

Air Weight

$$\text{Air weight at } 0^{\circ}\text{C} = 1,293 \text{ kg/m}^3$$

$$\text{Air weight at } 20^{\circ}\text{C} = 1,205 \text{ kg/m}^3$$

$$\text{Air weight at } 25^{\circ}\text{C} = 1,184 \text{ kg/m}^3$$

Engine Protection

in **All Conditions**

Like Never Before!

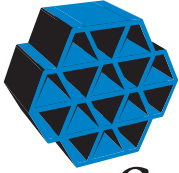

PowerCore®
A DONALDSON FILTRATION TECHNOLOGY

Innovative vehicle designs call for new engineering solutions plus know-how from your suppliers. We have both – and are ready to help you solve your space or configuration problems.

PowerCore filters in round, obround, and rectangular configurations.

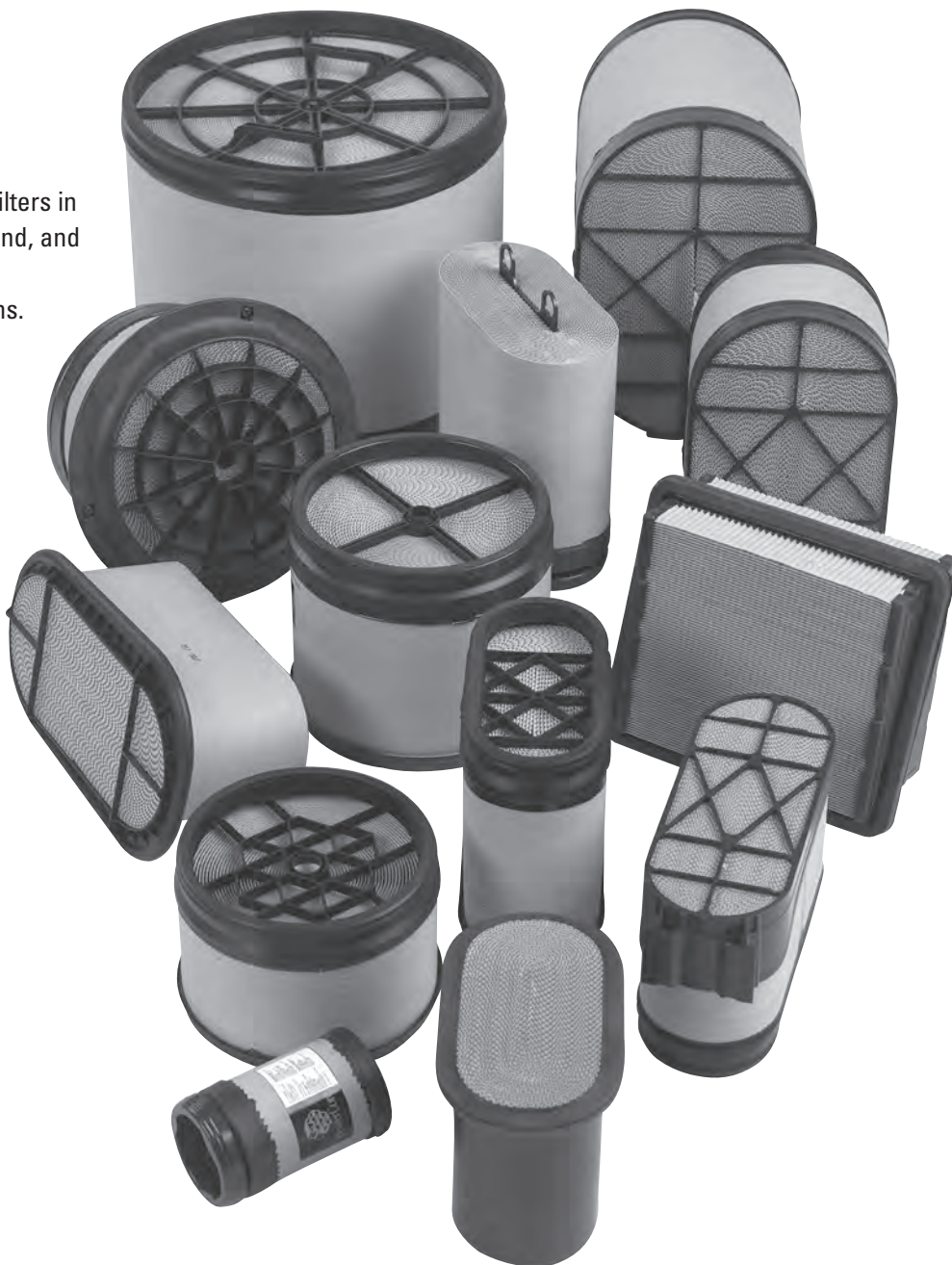

PowerCore® Delivers Improved Filtration Performance

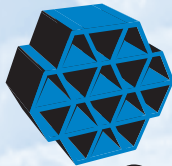

PowerCore®
A DONALDSON FILTRATION TECHNOLOGY

Section Index

| | |
|---------------------------------|----|
| PSD (Medium to Heavy Dust)..... | 19 |
| PSD Service Instructions | 34 |

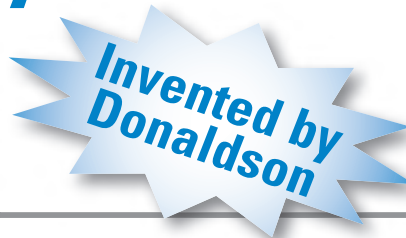
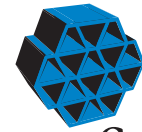

Why was it developed?

Vehicle design is moving from classic to aerodynamic. This means less under-hood space, highly stylized, cost effective designs, greater operator visibility, higher horsepower engines with greater airflow and other emission requirements with hotter engines...

Therefore Donaldson developed PowerCore® Filtration Technology, to do more in less space and to allow system optimization.

What is it about?

- Proprietary air filtration technology developed to improve engine protection.
- Revolutionary, fluted media design for improved air filtration.
- PowerCore® media is visually unique.
- PowerCore filters can be designed, based on an approved matrix, in obround (racetrack) and round shapes.
- High density media packaging technology.
- Built with Donaldson Technology.
- Backed by extensive lab and field testing

How does it work?

Clean air travels on to your engine

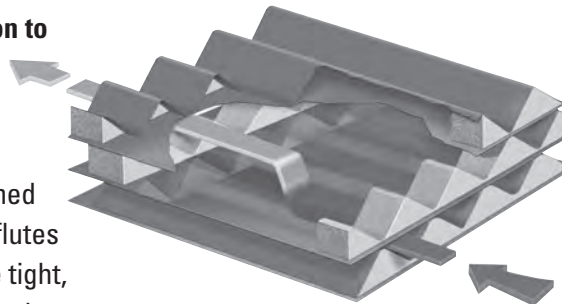

Filter media is formed into flutes - these flutes are layered to give tight, rugged structure to the filter

Fluted channels are alternately sealed: air enters an open flute and is forced to exit through an adjacent flute

Contaminants stay inside the filter - and won't drop back into an unprotected air filter housing.

Dirty air travels in and is filtered in one pass through the media

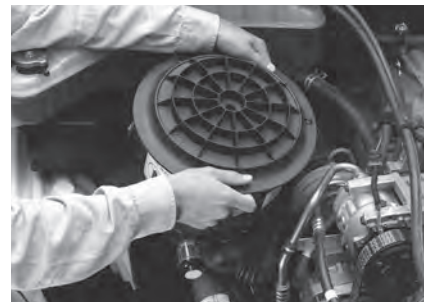

**Invented by
Donaldson**

With PowerCore, you will gain...

Greater Efficiency

The straight-through fluted design of PowerCore Filtration Technology is three times more efficient than average conventional pleated filters.

Engine Protection

No media movement, expansion, contraction or bunching, with less dust and dirt passed on to the engine.

Contaminant Encapsulation

Dust and dirt won't dislodge during servicing.

Equal or Better Performance in a Small Package

The freedom to design unique configurations to fit tight spots and overall design simplicity.

Donaldson Reliability

Backed by nearly a century of innovation and experience. Donaldson supplies air filtration products to almost every vehicle manufacturer.

Lower Shipping and Inventory Costs

PowerCore filters are lighter and take up less shelf space being so compact - in fact as much as half of a conventional filter.

Improved Handling and Maintenance

Lighter and smaller, changing filters is a snap.

Improved Environment Protection

Non-metal filters – both main and safety (where applicable).

System Design Flexibility

Multiple horizontal and vertical installation positions.

Dust Holding Capacity

Gain over 100% more dust holding capacity in a given volume.

Built-In Pre-Separation and Mounting Brackets

To eliminate the need to purchase separate.

PowerCore filters in round, obround, and rectangular configurations.

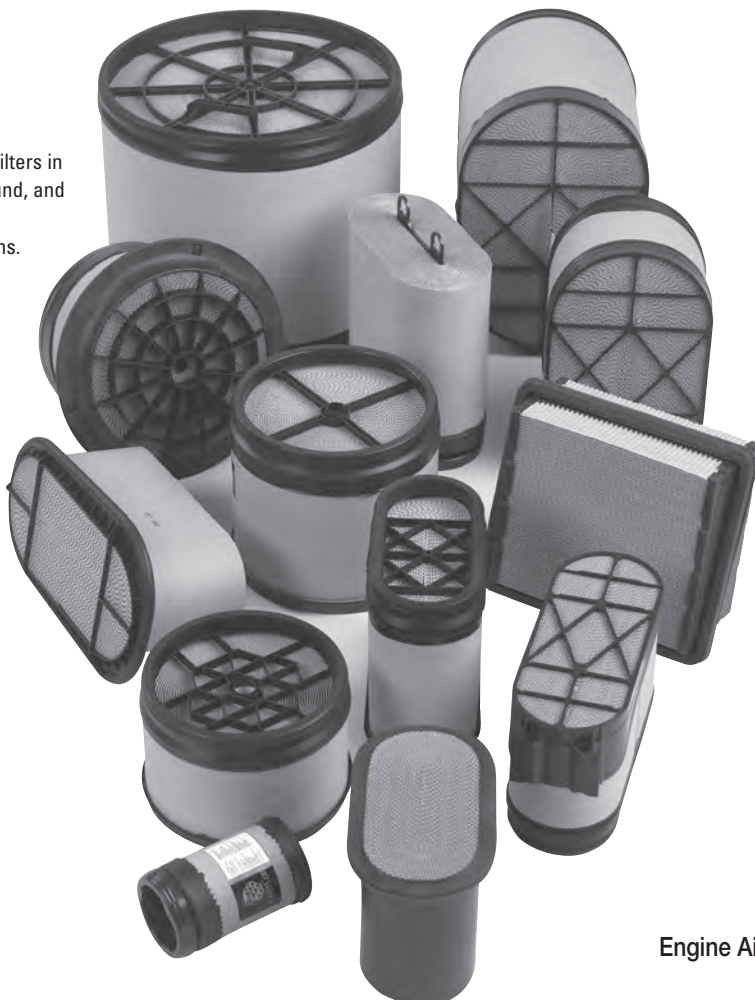

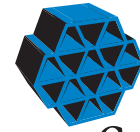

Excellent Performance in Half the Space

The PSD PowerCore[®] Air Cleaner is a two-stage air cleaner with built-in high efficiency pre-cleaner using PowerCore Filtration Technology.

PSD PowerCore Air Cleaners are designed especially for on and off road equipment operating in medium to heavy dust environments.

Can be used with Vacuator[™] Valve on the pre-cleaner or continuously scavenge of the pre-cleaner by an exhaust ejector or air blower cooling. See page 124-125 for all available Exhaust Ejectors.

Applications

- Equipment operating in medium to heavy dust conditions with engine airflow ranges up to 30 m³/min.
- Obround housing shape allows for a narrow or wide mounting orientation. Models have either end or side filter service access
- Sustained temperature tolerance: to 82°C

Features

- More compact at a given performance level than standard pleated filters
- Non-metal filters - both main and safety (where applicable)
- Improved engine protection: no media movement, expansion, contraction or bunching
- Improved contaminant encapsulation: dust and dirt stay contained in filter during service
- Improved filtration efficiency:
 - Three times more efficient than the average conventional pleated filter
 - PowerCore Filtration Technology with high efficiency pre-cleaner tubes improve engine protection
- Improved handling and maintenance: lighter and smaller, changing filters is a snap
- Easily serviced with clamp-on cover design
- Can be used with scavenge line or Vacuator[™] Valve depending on housing orientation
- Built in mounting brackets eliminate the need to purchase separate mounting bands
- Indicator thread size =
 - 1/8-27NPT (Male) for PSD08/PSD09/PSD10
 - 1/8-27NPT (Female) for PSD12

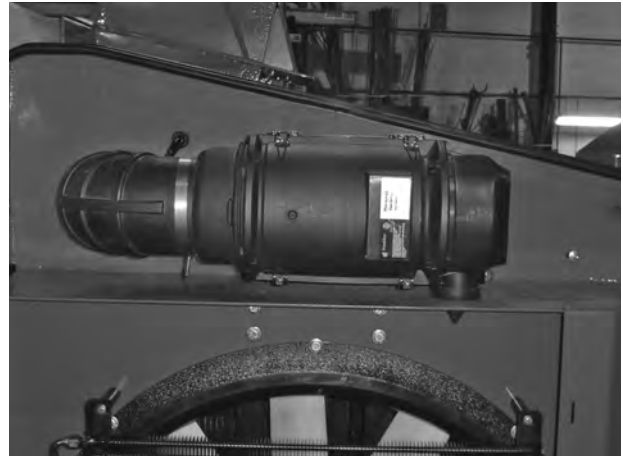

D080069 - Horizontal



D080070 - Vertical

Mounting Flexibility

The PSD air cleaner is available with two separate drop tube in orientations and built-in mounting brackets on the 2 long sides of the housing. The other three PSD models (09, 10 and 12) offer even more mounting flexibility with built-in brackets on three sides of the main body housing.



D090074 - Horizontal



D090073 - Vertical



D100030 - Horizontal



D100029 - Vertical

PSD 08 - Service Access on Inlet End



PSD 09-10-12- Service Access on Side

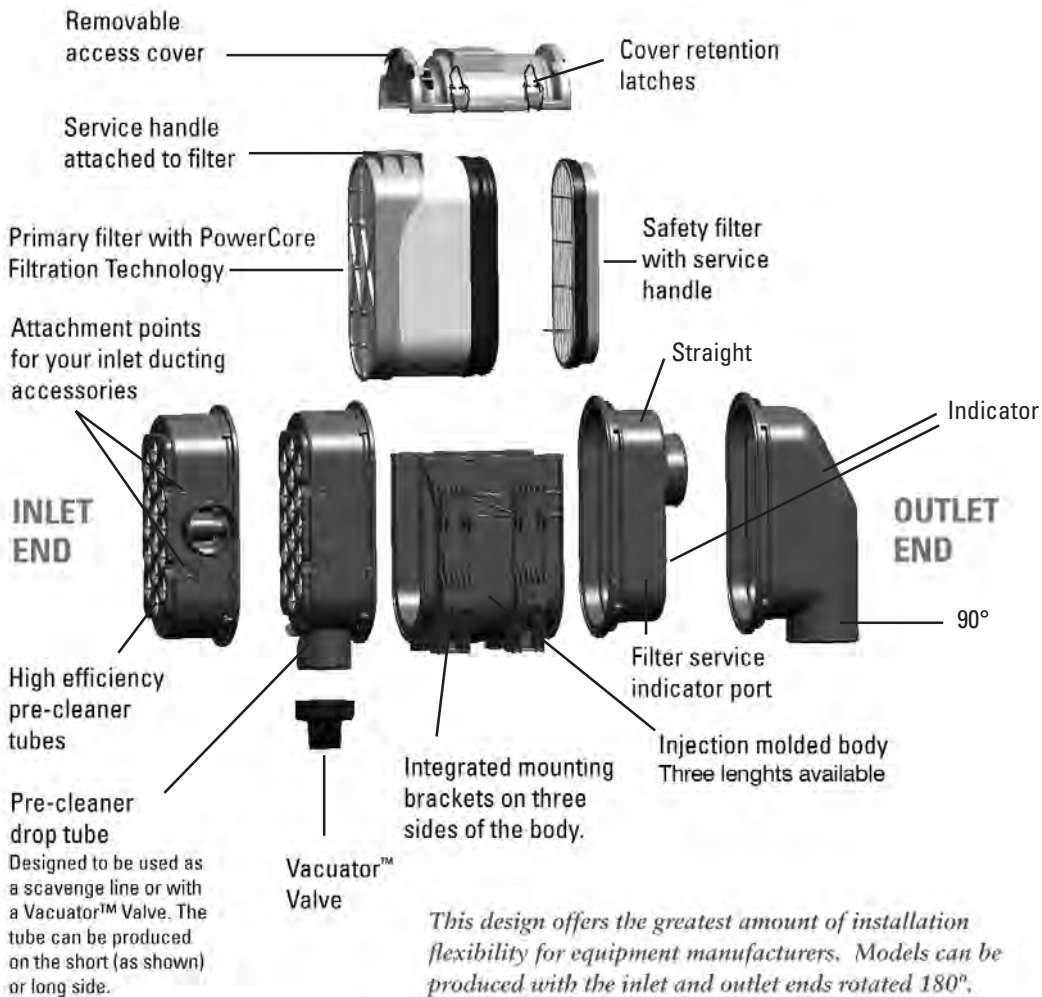

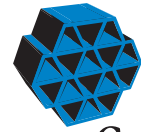

PSD 08 - Specifications

PowerCore®

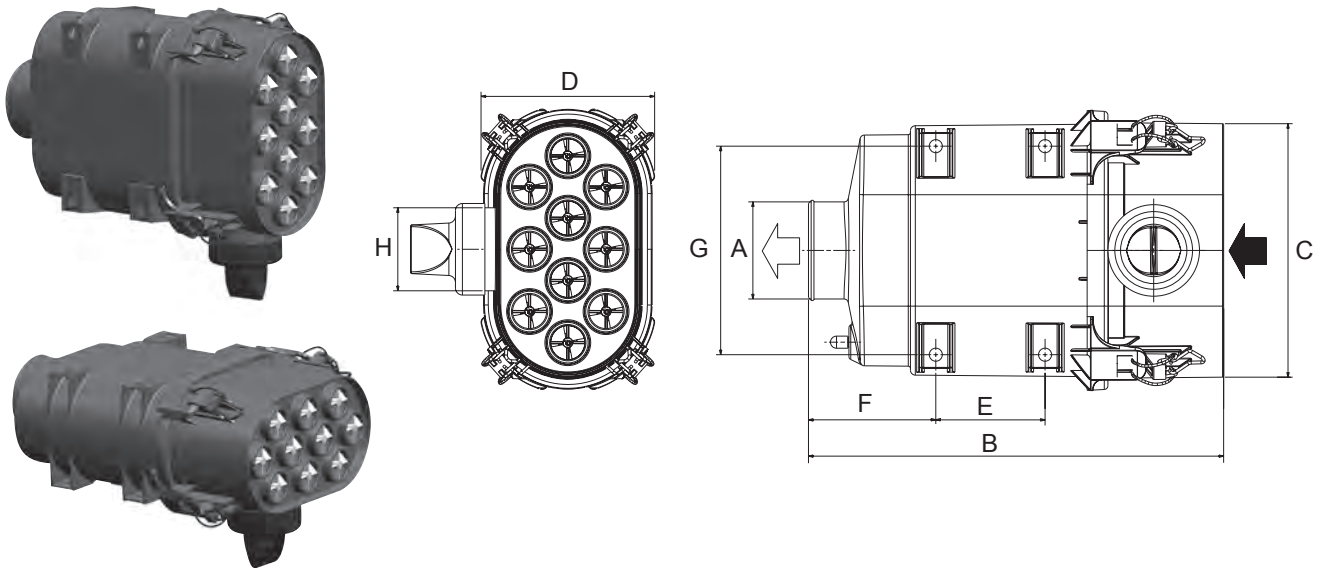

| Air Cleaner Model No. | Airflow Range m ³ /min. | Dimensions (mm) | | | | | | | |
|--|------------------------------------|--|-----|-----|-----|-----|-----|-----|----|
| | | A | B | C | D | E | F | G | H |
| D080069 (H) D080070 (V) With Vac Valve | up to 6 | 89 | 380 | 257 | 159 | 100 | 117 | 191 | 76 |
| D080069 (H) D080070 (V) With Scavenge Flow | up to 8,5 | (H) Horizontal / (V) Vertical Installation | | | | | | | |

To Scavenge or Not Scavenge...

PSD air cleaners are designed to operate with or without aspiration, otherwise known as scavenging. Scavenging is accomplished by introducing a secondary airflow to the drop tube on the air cleaner (generally through the use of an ejector or ejector muffler). This flow pulls the separated contaminant from the pre-cleaner and inserts it into the exhaust stream.

The advantages to scavenging are:

- Higher pre-cleaner efficiency (resulting in longer filter service life)
- Completely self-servicing (no regular maintenance needed on pre-cleaner)
- Drop tube can be located in variety of orientations (not just straight down as is necessary on non-scavenged systems)

Aspirating an intake system through the use of a scavenging device adds more components (an ejector and some plumbing) to the overall system, but will enhance the separator efficiency of the pre-cleaner and consequently extend the filter service life. Conversely, the PSD air cleaner and pre-cleaner will function adequately without scavenge, with the result being less filter service life than with the use of scavenging.

PSD 09 - 10 - 12 Specifications

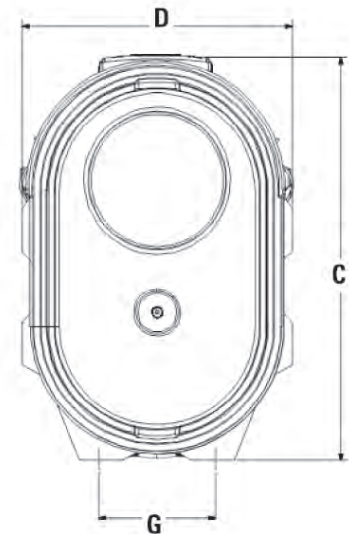
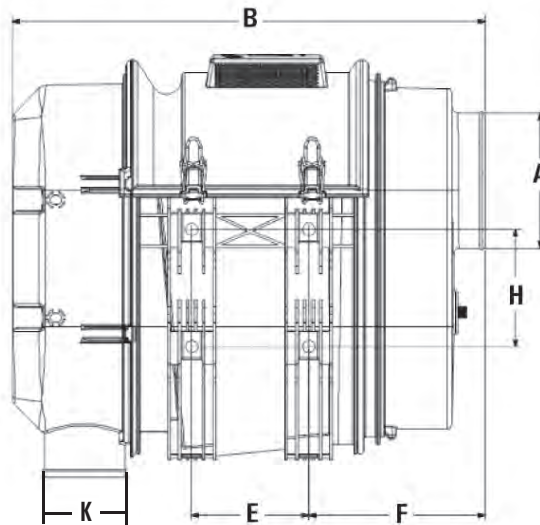

| Air Cleaner Model No. | Airflow Range m ³ /min. With 10% Scavenge Flow | Dimensions (mm) | | | | | | | | |
|-----------------------|---|-----------------|-----|-----|-----|-----|-----|-----|-----|------|
| | | A | B | C | D | E | F | G | H | K |
| D090073 (V) | 6-10 | 102 | 433 | 362 | 180 | 110 | 174 | 100 | 130 | 76,5 |
| D090074 (H) | 6-10 | 102 | 433 | 362 | 180 | 110 | 174 | 100 | 130 | 76,5 |
| D090099 (V) | 7-11 | 102 | 458 | 362 | 180 | 135 | 174 | 100 | 130 | 76,5 |
| D090098 (H) | 7-11 | 102 | 458 | 362 | 180 | 135 | 174 | 100 | 130 | 76,5 |
| D090101 (V) | 9-13 | 102 | 533 | 362 | 180 | 180 | 174 | 100 | 130 | 76,5 |
| D090100 (H) | 9-13 | 102 | 533 | 362 | 180 | 180 | 174 | 100 | 130 | 76,5 |
| D090086 (V)* | 6-10 | 102 | 477 | 362 | 180 | 110 | 218 | 100 | 130 | 76,5 |
| D090087 (H)* | 6-10 | 102 | 477 | 362 | 180 | 110 | 218 | 100 | 130 | 76,5 |
| D090088 (V)* | 7-11 | 102 | 502 | 362 | 180 | 135 | 218 | 100 | 130 | 76,5 |
| D090089 (H)* | 7-11 | 102 | 502 | 362 | 180 | 135 | 218 | 100 | 130 | 76,5 |
| D090090 (V)* | 9-13 | 102 | 577 | 362 | 180 | 180 | 218 | 100 | 130 | 76,5 |
| D090091 (H)* | 9-13 | 102 | 577 | 362 | 180 | 180 | 218 | 100 | 130 | 76,5 |
| D100029 (V) | 12-18 | 127 | 429 | 375 | 254 | 110 | 165 | 110 | 110 | 76,5 |
| D100030 (H) | 12-18 | 127 | 429 | 375 | 254 | 110 | 165 | 110 | 110 | 76,5 |
| D100031 (V) | 18-25 | 152 | 529 | 375 | 254 | 210 | 165 | 110 | 110 | 76,5 |
| D100032 (H) | 18-25 | 152 | 529 | 375 | 254 | 210 | 165 | 110 | 110 | 76,5 |
| D100124 (V)* | 12-18 | 127 | 505 | 375 | 254 | 110 | 241 | 110 | 110 | 76,5 |
| D100123 (H)* | 12-18 | 127 | 505 | 375 | 254 | 110 | 241 | 110 | 110 | 76,5 |
| D100122 (V)* | 18-25 | 127 | 605 | 375 | 254 | 210 | 241 | 110 | 110 | 76,5 |
| D100121 (H)* | 18-25 | 127 | 605 | 375 | 254 | 210 | 241 | 110 | 110 | 76,5 |
| D120035 (V) | 23-27 | 152 | 496 | 430 | 306 | 168 | 160 | 154 | 110 | 76 |
| D120036 (H) | 23-27 | 152 | 496 | 430 | 306 | 168 | 160 | 154 | 110 | 76 |
| D120037 (V) | 27-30 | 152 | 596 | 442 | 306 | 268 | 160 | 154 | 110 | 76 |
| D120038 (H) | 27-30 | 152 | 596 | 442 | 306 | 268 | 160 | 154 | 110 | 76 |

(H) Horizontal / (V) Vertical Installation * 90° Outlet

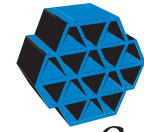

PSD PowerCore® - Service Parts

| | | | | | Service Parts | | | |
|-----------------------|--------------------------|---------|-----------------------|--------------------|-------------------|-----------------------|--------------|----------------|
| Air Cleaner Model No. | Air Cleaner Installation | Version | Orientation Drop Tube | Orientation Outlet | Access Cover Assy | U-Clip, Mounting (x4) | Main Element | Safety Element |
| D080069 | Horizontal | - | Horizontal | Straight | P785236 | P786050 | P608533 | P600975 |
| D080070 | Vertical | - | Vertical | Straight | P785237 | P786050 | P608533 | P600975 |
| D090073 | Vertical | Short | Vertical | Straight | P785651 | P784517 | P608665 | P606121 |
| D090074 | Horizontal | Short | Horizontal | Straight | P785651 | P784517 | P608665 | P606121 |
| D090099 | Vertical | Medium | Vertical | Straight | P785978 | P784517 | P787281 | P606121 |
| D090098 | Horizontal | Medium | Horizontal | Straight | P785978 | P784517 | P787281 | P606121 |
| D090101 | Vertical | Long | Vertical | Straight | P786989 | P784517 | P608675 | P606121 |
| D090100 | Horizontal | Long | Horizontal | Straight | P786989 | P784517 | P608675 | P606121 |
| D090086 | Vertical | Short | Vertical | 90° | P785651 | P784517 | P608665 | P606121 |
| D090087 | Horizontal | Short | Horizontal | 90° | P785651 | P784517 | P608665 | P606121 |
| D090088 | Vertical | Medium | Vertical | 90° | P785978 | P784517 | P787281 | P606121 |
| D090089 | Horizontal | Medium | Horizontal | 90° | P785978 | P784517 | P787281 | P606121 |
| D090090 | Vertical | Long | Vertical | 90° | P786989 | P784517 | P608675 | P606121 |
| D090091 | Horizontal | Long | Horizontal | 90° | P786989 | P784517 | P608675 | P606121 |
| D100029 | Vertical | Short | Vertical | Straight | Upon request | P784517 | P608666 | P601560 |
| D100030 | Horizontal | Short | Horizontal | Straight | Upon request | P784517 | P608666 | P601560 |
| D100031 | Vertical | Long | Vertical | Straight | Upon request | P784517 | P608676 | P601560 |
| D100032 | Horizontal | Long | Horizontal | Straight | Upon request | P784517 | P608676 | P601560 |
| D100124 | Vertical | Short | Vertical | 90° | Upon request | P784517 | P608666 | P601560 |
| D100123 | Horizontal | Short | Horizontal | 90° | Upon request | P784517 | P608666 | P601560 |
| D100122 | Vertical | Long | Vertical | 90° | Upon request | P784517 | P608676 | P601560 |
| D100121 | Horizontal | Long | Horizontal | 90° | Upon request | P784517 | P608676 | P601560 |
| D120035 | Vertical | Short | Vertical | Straight | Upon request | P784517 | P608667 | P607557 |
| D120036 | Horizontal | Short | Horizontal | Straight | Upon request | P784517 | P608667 | P607557 |
| D120037 | Vertical | Long | Vertical | Straight | Upon request | P784517 | P608677 | P607557 |
| D120038 | Horizontal | Long | Horizontal | Straight | Upon request | P784517 | P608677 | P607557 |

Accessories used on all PSD Air Cleaners

| | |
|-----------------|---|
| Vacuator™ Valve | P112803 for the European PSD Range / P158914 for the US PSD Range - See page 27. When making use of a reducer, see page 141 for all available Vac Valves |
| Check Valve | P784790 for the PSD Range. See page 126 for all available Check Valves. |
| Adapters | ø 32 = P783747 ø 38 = P783746 ø 50 = P783748 ø 25 + 90° = P786685 ø 32 + 90° = P784019 (PP) ø 32 + 90° = P784834 (PA) ø 38 + 90° = P786778 |
| Ejectors | See page 124-125 for all available Exhaust Ejectors |



Media used on PSD PowerCore® Standard Air Cleaners

All PSD Standard Air Cleaners are equipped with White Media, Blue Ultra-Web® Media is optional. Contact your Donaldson representative for more info.

PSD Extended Product Line

For the PowerCore™ Air Cleaner Range, Donaldson now offers you more alternatives - an extended product line. These new alternatives provide you more flexibility and mounting options. A new range of accessories is also available (see page 26).

| Standard PSD PowerCore® Line | | |
|------------------------------|-----------------|----------|
| US Models | European Models | |
| PSD08 | | |
| D080020 | D080069 | New |
| D080026 | D080070 | New |
| PSD09 | | |
| D090019 | D090073 | New |
| D090020 | D090074 | New |
| - | D090099 | New |
| - | D090098 | New |
| D090021 | D090101 | New |
| D090022 | D090100 | New |
| - | D090086 | New |
| - | D090087 | New |
| - | D090088 | New |
| - | D090089 | New |
| - | D090090 | New |
| - | D090091 | New |
| PSD10 | | |
| - | D100029 | Existing |
| - | D100030 | Existing |
| - | D100031 | Existing |
| - | D100032 | Existing |
| - | D100124 | New |
| - | D100123 | New |
| - | D100122 | New |
| - | D100121 | New |
| PSD12 | | |
| D120035 | - | Existing |
| D120036 | - | Existing |
| D120037 | - | Existing |
| D120038 | - | Existing |

PSD08 Extended Product Line - Features



- Lower initial restriction
- Mounting brackets on both sides to increase mounting options
- Drop tube diameter enlarged (same as PSD10 & 12)
- Possibility to fix different scavenge adapters > straight & 90°
- Possibility to integrate check-valve into scavenge tube of pre-cleaner
- 4 latches on service cover to improve accessibility & serviceability

PSD09 Extended Product Line - Features



- Lower initial restriction
- Next to the short and long PSD09 we offer now a medium version
- Drop tube diameter enlarged (same as PSD10 & 12)
- Possibility to fix different scavenge adapters > straight & 90°
- Possibility to integrate check-valve into scavenge tube of pre-cleaner
- Optional 45° latch position on the cover
- New version with 90° outlet tube
- Male indicator tab with thread 1/8 27 NPT

PSD10 Extended Product Line - New features



- New version with 90° outlet tube

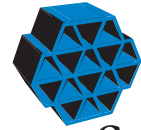

When specifying an Air Cleaner...

Determine the Airflow Requirements of your engine, then find the corresponding m^3/min . airflow in the charts below. The restriction numbers - shown in mbar at the left side of the chart - indicate the approximate initial restriction of each model air cleaner at that m^3/min . When calculating total initial restriction of the entire air intake system, include the restriction caused by ducting, elbows, pre-cleaners, etc. The estimated lab life hours are indicated at the right side of the chart.

PSD 08 Performance Curves

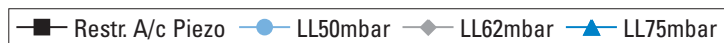
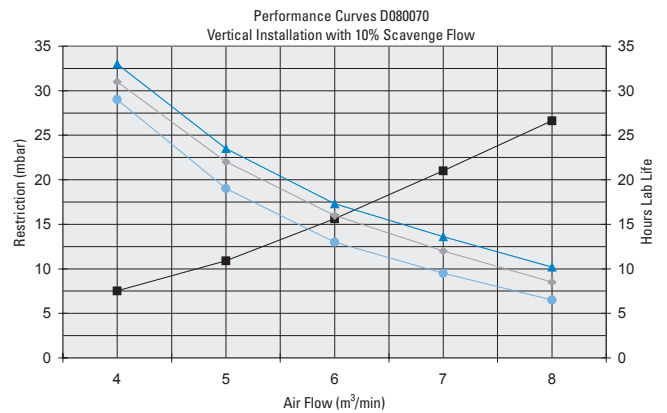
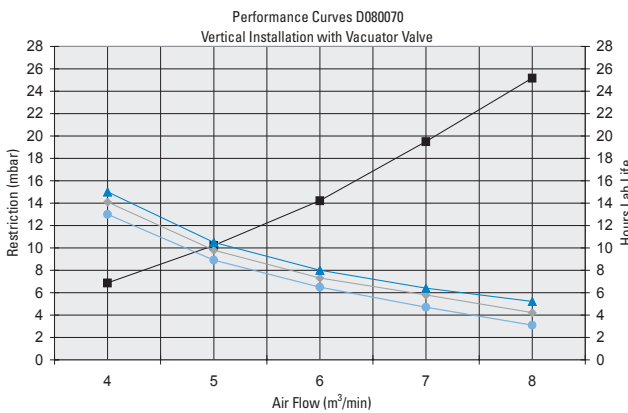
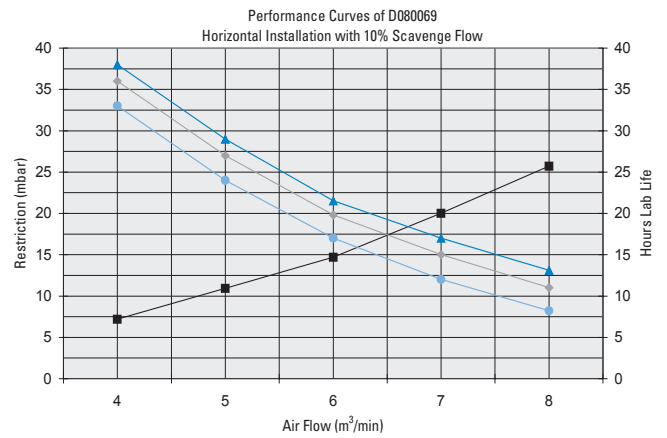
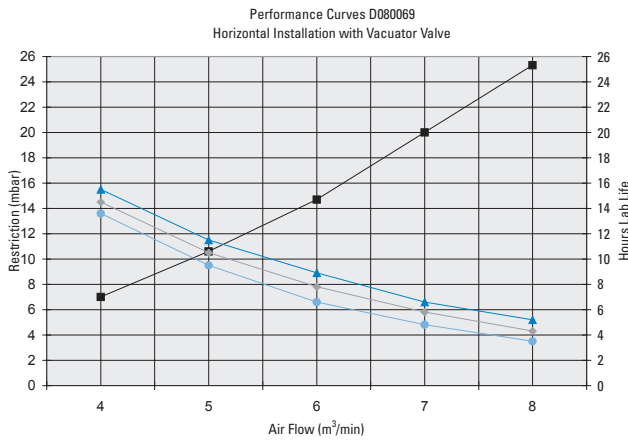

All performance curves are according ISO 5011 standards - Restriction measured at Piezo
All tests are done with ISO Coarse at Dust Concentration of $1g/m^3$

PSD 09 Performance Curves

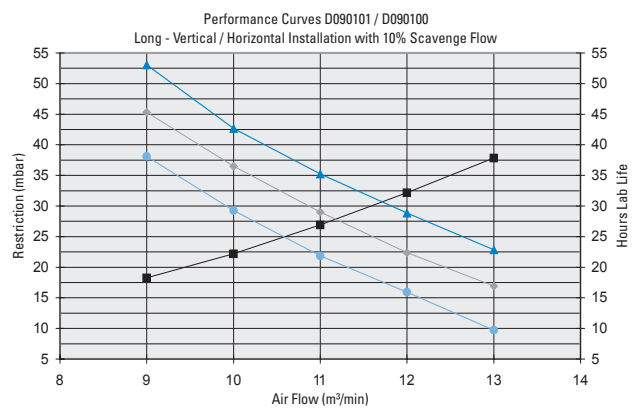
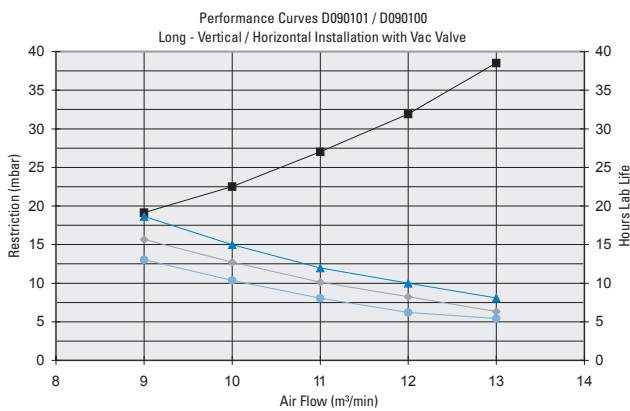
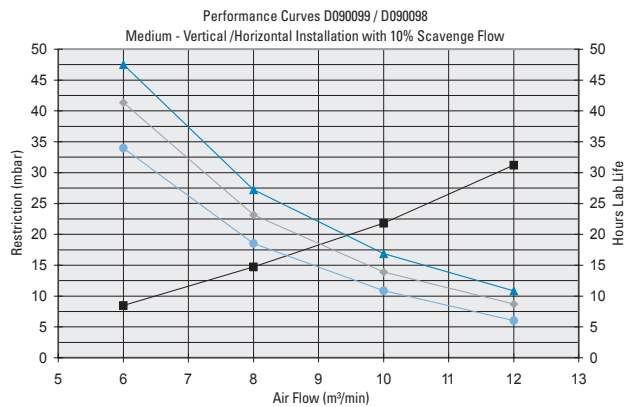
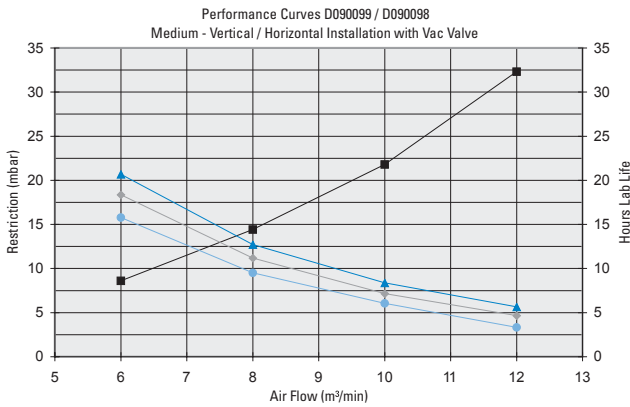
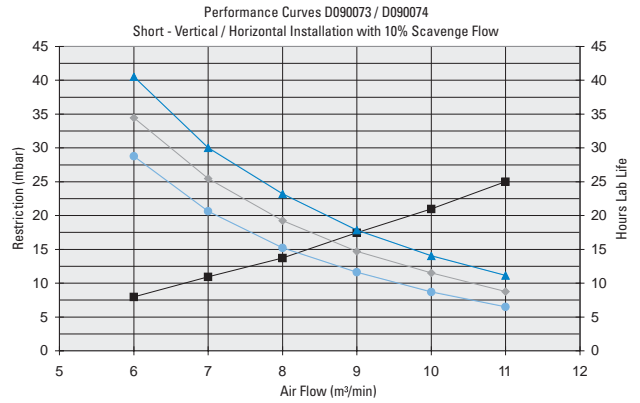
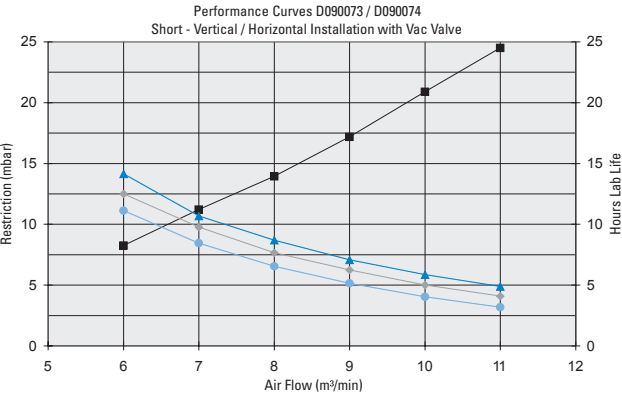

All performance curves are according ISO 5011 standards - Restriction measured at Piezo
All tests are done with ISO Coarse at Dust Concentration of 1g/m³

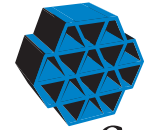

PSD 09 Performance Curves

PowerCore®

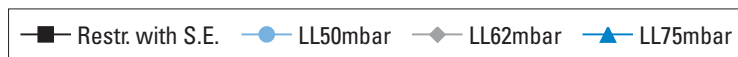
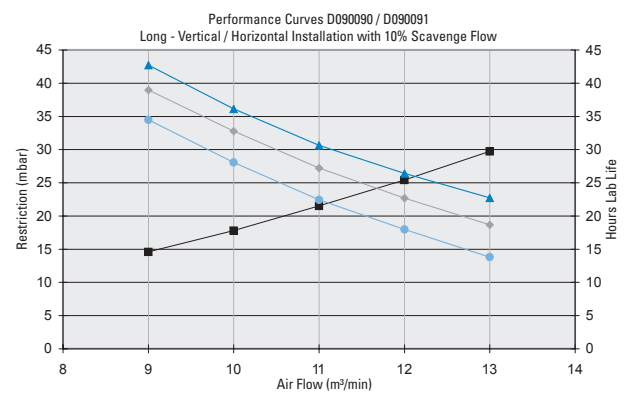
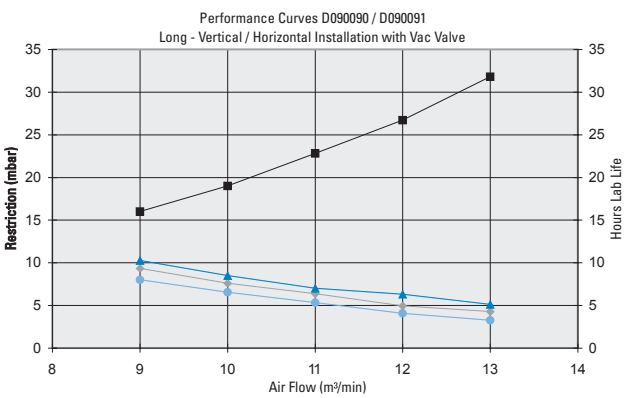
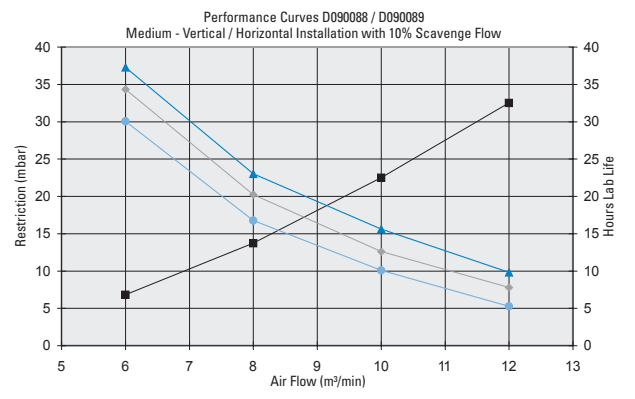
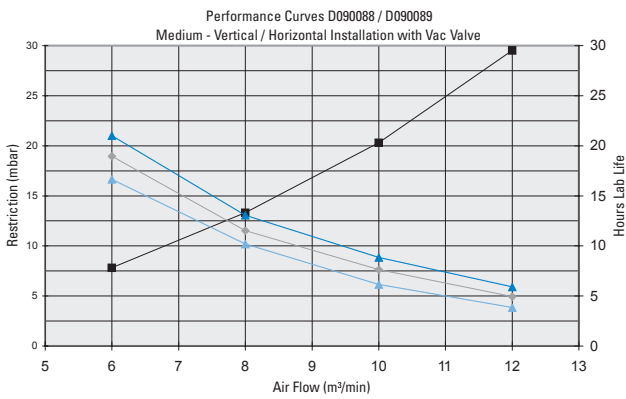
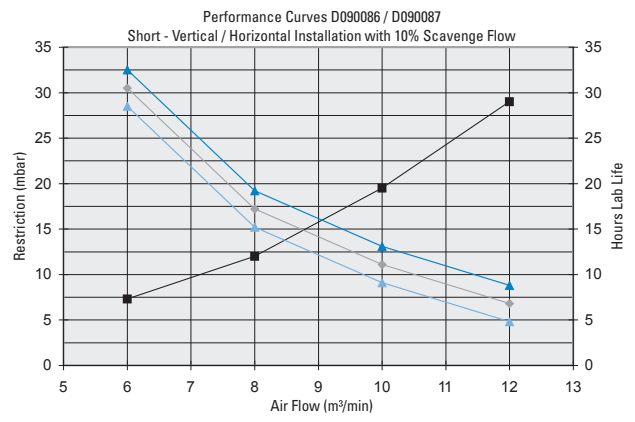
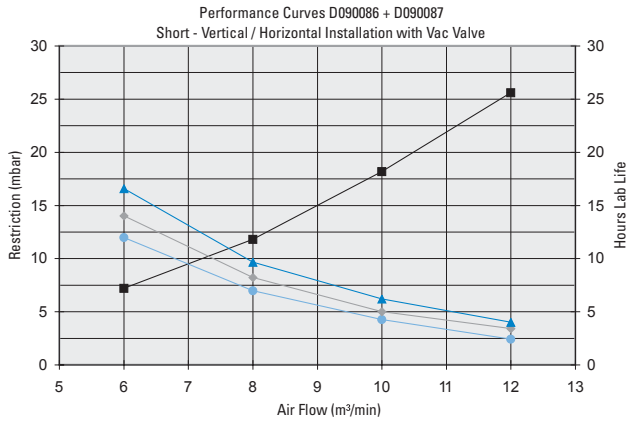

All performance curves are according ISO 5011 standards - Restriction measured at Piezo
All tests are done with ISO Coarse at Dust Concentration of 1g/m³

PSD 10 Performance Curves

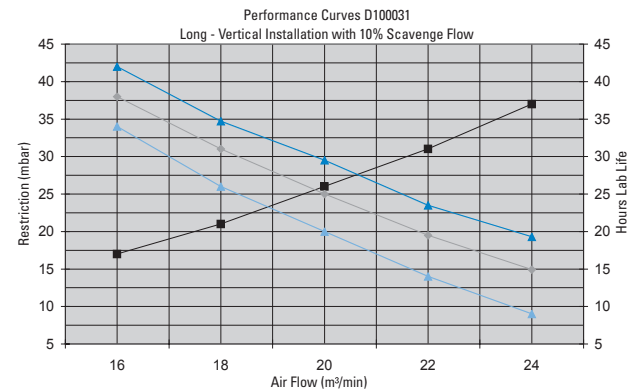
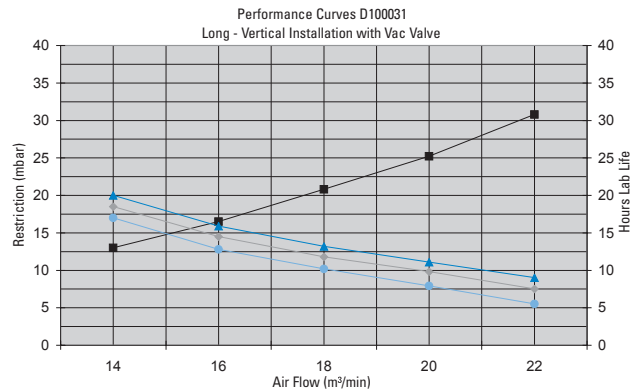
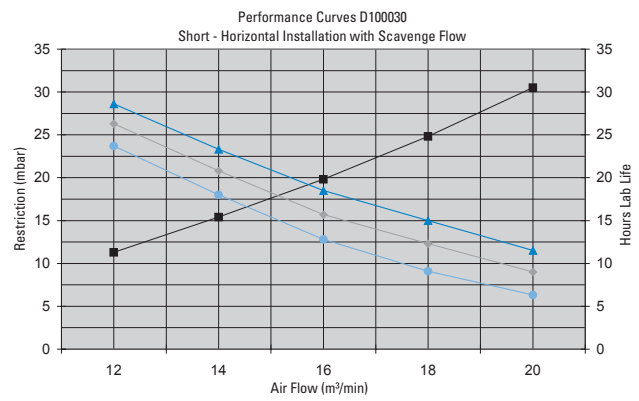
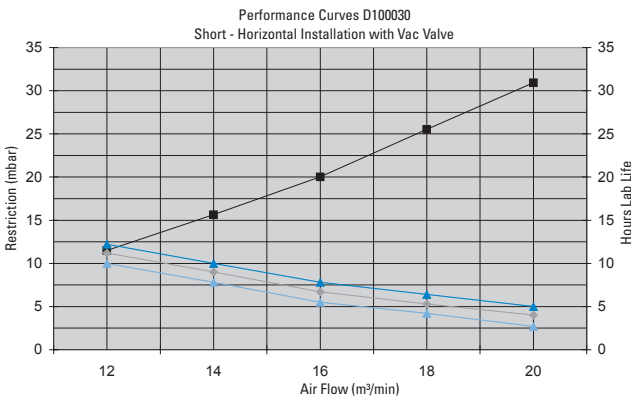
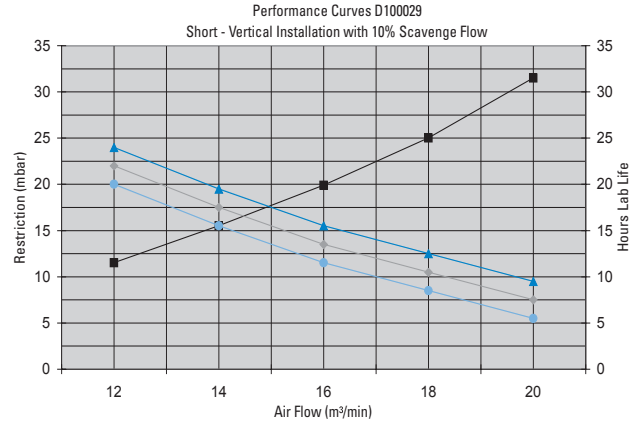
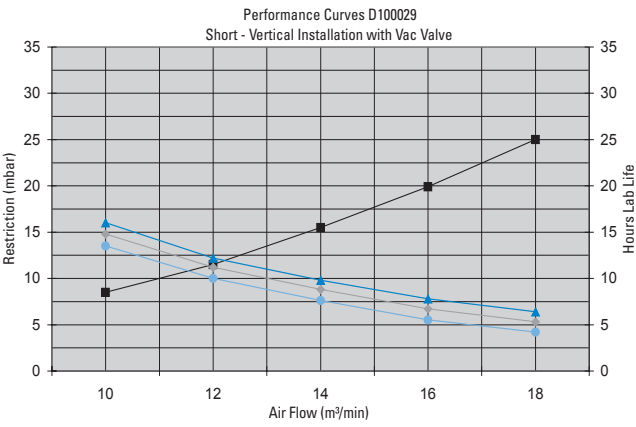

Restr. A/c Piezo
 LL50mbar
 LL62mbar
 LL75mbar

All performance curves are according ISO 5011 standards - Restriction measured at Piezo
 All tests are done with ISO Coarse at Dust Concentration of 1g/m³

PowerCore®

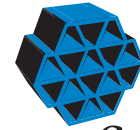

PSD 10 Performance Curves

PowerCore®

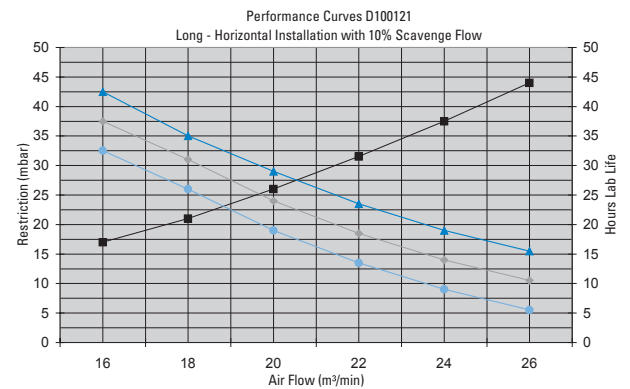
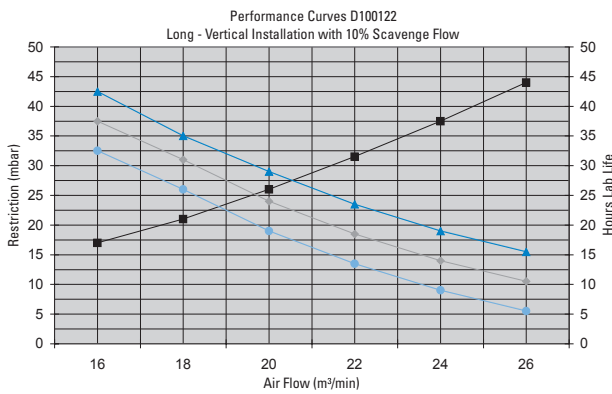
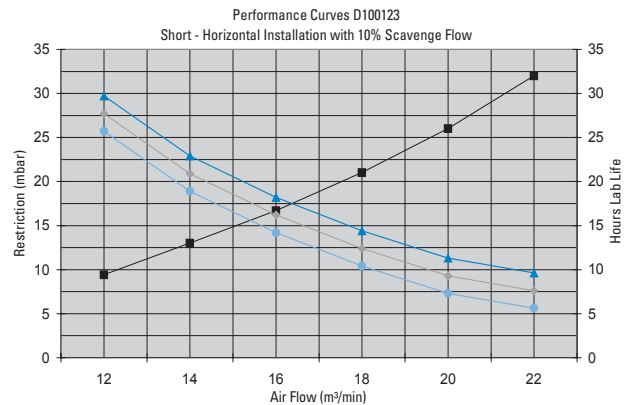
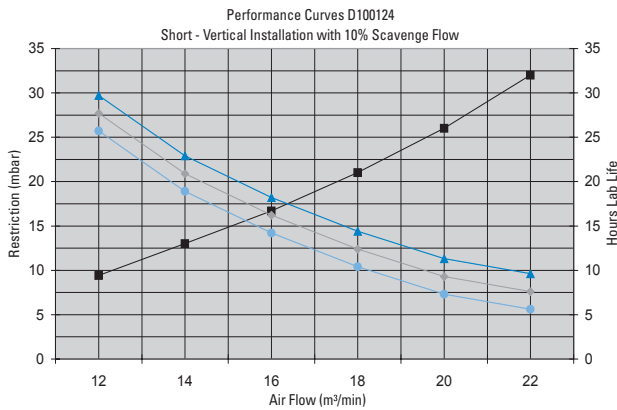
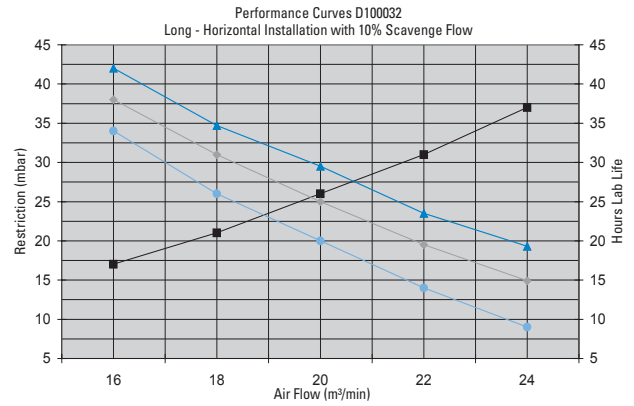
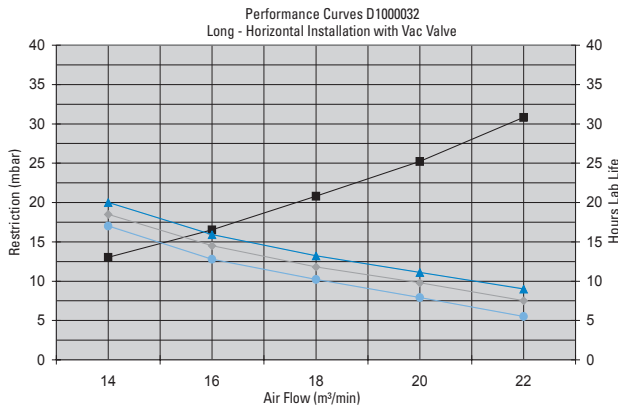

Restr. A/c Piezo
 LL50mbar
 LL62mbar
 LL75mbar

All performance curves are according ISO 5011 standards - Restriction measured at Piezo
 All tests are done with ISO Coarse at Dust Concentration of 1g/m³

PSD 12 Performance Curves

Performance Curves PSD120035/36 acc. ISO5011 with 10% Scavange (vertically installed)

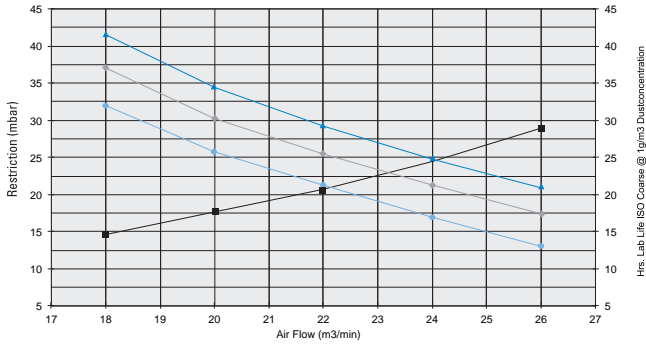

Performance Curves PSD120035/36 acc. ISO5011 with Vacuator Valve (vertically installed)

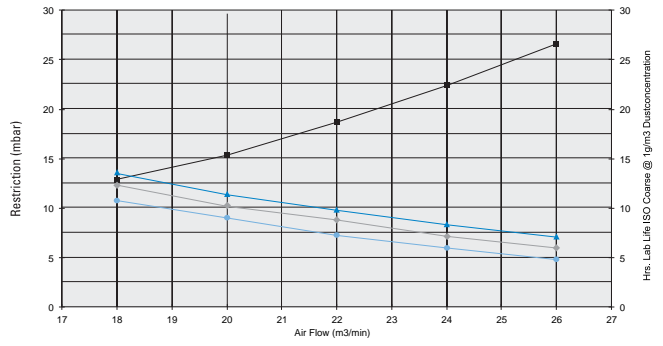

Performance Curves PSD120037/38 acc. ISO5011 with Vacuator Valve (vertically installed)

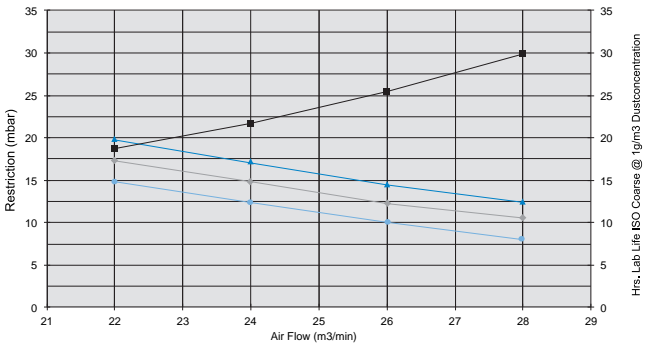

Performance Curves PSD120037/38 acc. ISO5011 with 10% scavange (vertically installed)

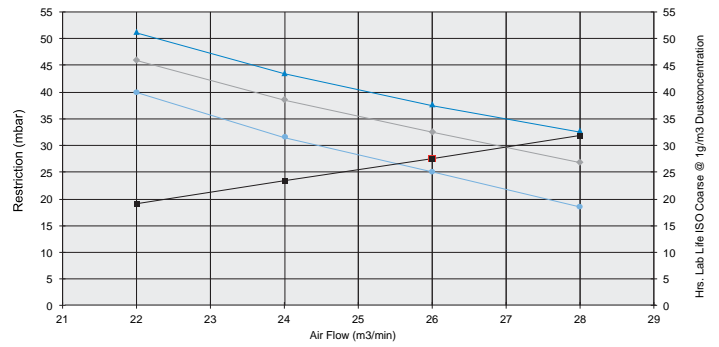

Restr. with S.E.
 LL50mbar
 LL62mbar
 LL75mbar

All performance curves are according ISO 5011 standards - Restriction measured at Piezo
 All tests are done with ISO Coarse at Dust Concentration of 1g/m³

Note: Your air cleaner service cover may be in a different position than shown.

PSD09, PSD10
or PSD12 Style

PSD08 Style

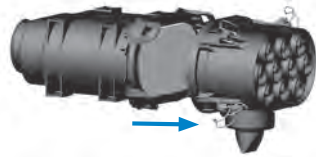

1 Shut off engine. Unlatch and remove the housing service cover.



2 Remove primary filter. Pull the filter out of housing. On PSD09, PSD10, and PSD12 you must first loosen the filter gasket seal. Using the handle, push down on the filter to loosen the seal, which will tilt the filter to approximately a 5° angle.

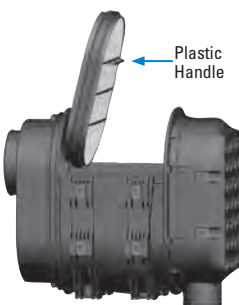

3 Remove safety filter. Using the plastic handle on the face of the safety filter, pull the filter toward the center of the housing and remove. **Note:** A safety filter only needs to be replaced at every third primary air filter change.



4 Inspect the new filter before installing. Visually check for cuts, tears, or indentations on the sealing surfaces before installation. If any damage is visible, do not install.

PSD09, PSD10 or PSD12 Style

PSD08 Style

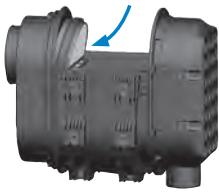

Safety Filter
Positioning Tab Location



Plastic
Handle

5 If replacing safety, using the plastic handle on the safety filter, slide the filter at an angle into the outlet side and push in place until the filter seats firmly and evenly within the housing. **Note:** On PSD09, PSD10 and PSD12 models, insert the safety filter tab into the positioning slot before pushing the filter in place.

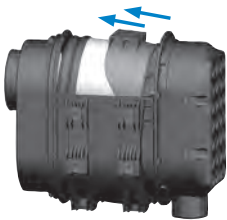

6 Insert the primary filter. For PSD08, slide the filter into the housing until the gasket seats against the housing. For PSD09, PSD10 and PSD12, slide the filter down at approximately a 5° angle until it hits the end of the housing. Rotate the filter toward the outlet section to complete the seal.

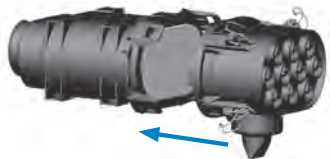

7 Replace the service cover. On PSD08, tilt the service cover into place and secure latches. For the PSD09, PSD10 and PSD12, place the service cover in position and fasten the latches. **Note:** If the cover doesn't seat, remove and re-check the filter position. The cover will be difficult to install if the filter isn't installed correctly.



8 Visually inspect your inlet and outlet connections. If your air cleaner has a Vacuator Valve, inspect the valve. Replace if any signs of wear or damage are visible.

Engine Protection

in **All Conditions**

Like Never Before!

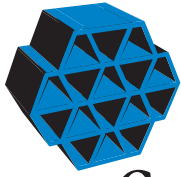

PowerCore[®]
A DONALDSON FILTRATION TECHNOLOGY

Innovative vehicle designs call for new engineering solutions plus know-how from your suppliers. We have both – and are ready to help you solve your space or configuration problems.

PowerCore filters in round, obround, and rectangular configurations.

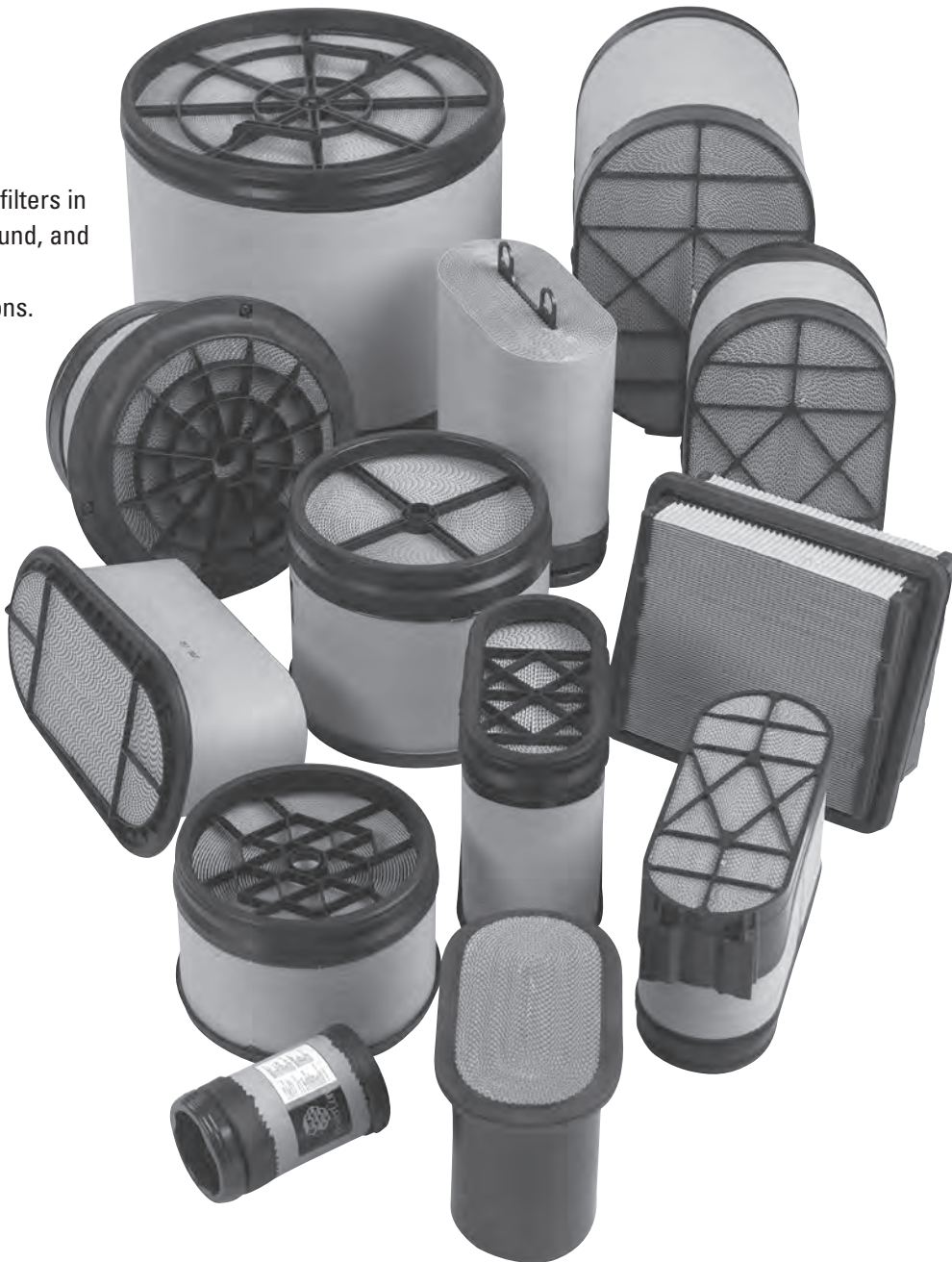

Air Cleaners used in Light Dust Conditions

... Donaldson offers a full line of air cleaners for a wide variety of applications and operating environments.

Section Index

| | |
|------------------------------------|----|
| DuraLite™ ECB, ECC, ECD | 38 |
| DuraLite Service Instructions..... | 42 |
| EPB | 43 |
| EPB Service Instructions..... | 48 |
| ERB2 | 43 |
| ERB2 Service Instructions..... | 48 |

**UNIQUE
DESIGN
CONCEPT**

DuraLite™ ECB, ECC, ECD Air Cleaner



Convenient DuraLite Disposables Rugged Air Cleaners for Small and/or High Pulsation Gas & Diesel Engines

The DuraLite™ Air Cleaners are disposable, one-stage, dry air cleaners which are used on light-duty applications like air compressors, pumps, material handling equipment, propulsion units, breathers, welders, generator sets, lawn vehicles, recreation vehicles and many more. Ideal for high pulsating small engines.

Donaldson's DuraLite™ air cleaners are tough, non-metallic, lightweight, self-supporting and completely disposable. They are also easy to install, durable, and reliable.

They are designed to function well under high and severe pulsation conditions found in many applications, especially two- and three-cylinder engines. Vibration-resistant media is potted into molded housings of rugged ABS plastic - so they don't fall apart as other designs might.

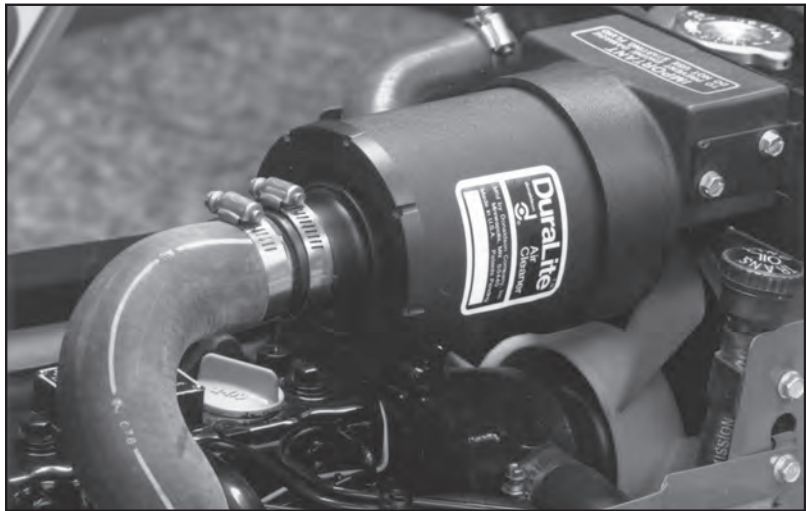

Light Dust Conditions

Applications

- Can be mounted vertically or horizontally.
- Provides variety of airflow volumes to engine: from 1 to 90 m³/min.
- Temperature tolerance: to 83°C continuous / 105°C intermittent.



Donaldson recommends the use of a high torque clamp for DuraLite air cleaners. This clamp eliminates the need for double clamping - order one for each DuraLite™ Air Cleaner. See page 120 for more information.

Air Cleaner Features

- No serviceable parts! Air cleaner housing and filter are one unit!
- Designed to withstand severe intake pulsation.
- Economical replacement cost.
- Self-supporting, sturdy.
- Very reliable: only one critical seal.
- Lightweight and compact in size.
- Non-metallic, non-corrosive... ideal for marine applications.
- Completely disposable... acceptable for normal trash pick-up (DuraLite™ should not be incinerated).
- Easily installed & maintained.
- Minimal removal clearance needed: only 38 mm.
- Three airflow styles available to fit virtually any engine intake configuration.
- Various media available for specific applications: high pulsation, high humidity, etc....

DuraLite™ Specifications

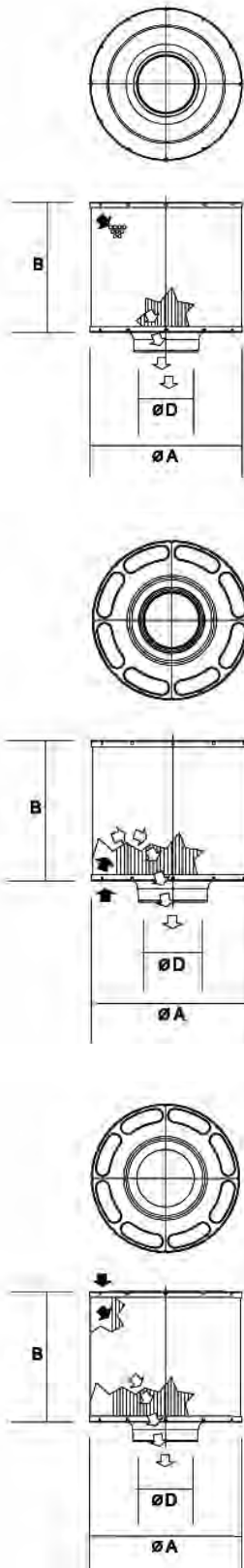

| Curve No. | Style | Air Cleaner Model No. | Airflow Range m ³ /min. | Dimensions (mm) | | |
|-----------|-------|-----------------------|------------------------------------|-----------------|-----|-----|
| | | | | A | B | D |
| 1 | ECB | B085001 | 6 - 12 | 216 | 279 | 76 |
| 1 | ECB | B085048** | 6 - 12 | 216 | 279 | 76 |
| 2 | ECB | B085011 | 7 - 14 | 216 | 279 | 102 |
| 2 | ECB | B085046** | 7 - 14 | 216 | 279 | 102 |
| 3 | ECB | B085056** | 27 - 49 | 196 | 260 | 152 |
| 4 | ECB | B100094** | 15 - 27 | 267 | 228 | 102 |
| 5 | ECB | B105002* | 16 - 30 | 267 | 381 | 127 |
| 6 | ECB | B105006 | 13 - 25 | 267 | 267 | 102 |
| 7 | ECB | B105012** | 18 - 36 | 267 | 381 | 127 |
| 8 | ECB | B120376** | 30 - 90 | 318 | 400 | 198 |
| 9 | ECB | B125003* | 16 - 31 | 318 | 381 | 153 |
| 10 | ECB | B125005** | 25 - 42 | 318 | 229 | 140 |
| 11 | ECB | B125011** | 22 - 39 | 318 | 228 | 127 |
| Curve No. | Style | Air Cleaner Model No. | Airflow Range m ³ /min. | Dimensions (mm) | | |
| | | | | A | B | D |
| 12 | ECC | C045001* | 1 - 3 | 114 | 114 | 38 |
| 13 | ECC | C045002* | 2 - 3 | 114 | 203 | 38 |
| 14 | ECC | C055002* | 2 - 4 | 140 | 178 | 45 |
| 15 | ECC | C055003* | 1,5 - 3 | 140 | 102 | 45 |
| 16 | ECC | C055008* | 2 - 4 | 140 | 242 | 45 |
| 17 | ECC | C065001* | 2 - 3 | 165 | 102 | 51 |
| 18 | ECC | C065002* | 3 - 5 | 165 | 190 | 51 |
| 19 | ECC | C065003* | 2,5 - 5 | 165 | 127 | 57 |
| 20 | ECC | C065004* | 3 - 6 | 165 | 229 | 57 |
| 21 | ECC | C065015** | 3 - 6 | 165 | 229 | 51 |
| 22 | ECC | C085001* | 3 - 5 | 216 | 102 | 64 |
| 23 | ECC | C085002* | 3 - 6 | 216 | 165 | 64 |
| 24 | ECC | C085003* | 4 - 7 | 216 | 127 | 76 |
| 25 | ECC | C085004* | 5 - 10 | 216 | 241 | 76 |
| 26 | ECC | C085005* | 3 - 5 | 216 | 127 | 64 |
| 27 | ECC | C085006* | 3,5 - 6,5 | 216 | 241 | 64 |
| 28 | ECC | C105003 | 9 - 17 | 267 | 152 | 102 |
| 29 | ECC | C105004 | 10,5 - 20 | 267 | 267 | 102 |
| 30 | ECC | C125003 | 10 - 19 | 317 | 152 | 127 |
| 31 | ECC | C125004 | 14 - 26,5 | 317 | 279 | 127 |
| Curve No. | Style | Air Cleaner Model No. | Airflow Range m ³ /min. | Dimensions (mm) | | |
| | | | | A | B | D |
| 32 | ECD | D045003* | 1 - 3 | 114 | 114 | 38 |
| 33 | ECD | D045004* | 1 - 3 | 114 | 152 | 38 |
| 34 | ECD | D055004* | 2 - 3,5 | 140 | 178 | 45 |
| 35 | ECD | D065003* | 2 - 3 | 165 | 102 | 51 |
| 36 | ECD | D065008** | 3,5 - 7 | 165 | 229 | 51 |
| 37 | ECD | D085011 | 8 - 15,5 | 197 | 655 | 106 |
| 38 | ECD | D085012 | 2,5 - 7,5 | 197 | 258 | 106 |
| 39 | ECD | D125004 | 12 - 23 | 317 | 279 | 127 |

* High pulsation media ** Marine application

Light Dust Conditions

When specifying an Air Cleaner...

Determine the Airflow Requirements of your engine, then find the corresponding m³/min. airflow in the charts below. The restriction numbers - shown in mbar - indicate the approximate initial restriction of each model air cleaner at that m³/min. If there are two air cleaner models that fit your parameters, choosing the one with the lowest restriction will provide the longest service life. When calculating total initial restriction of the entire air intake system, include the restriction caused by ducting, elbows, pre-cleaners, etc.

DuraLite™ ECB Restriction Curves

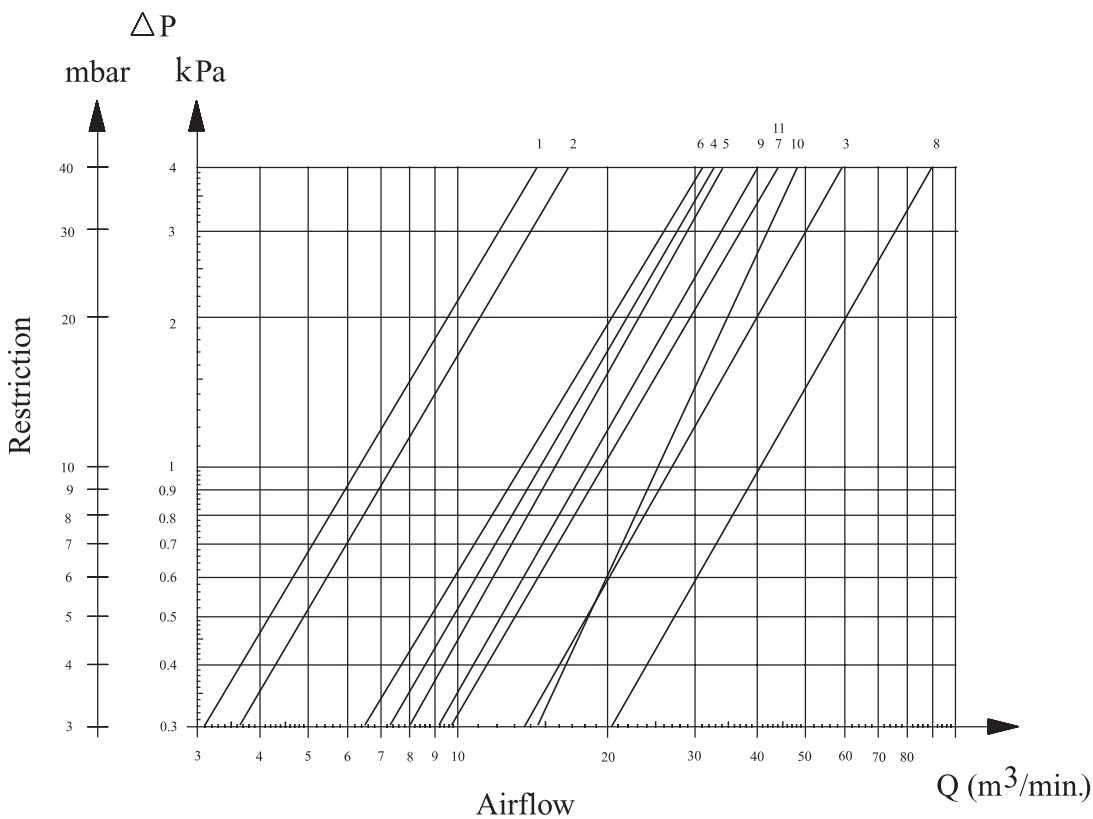

Light Dust Conditions

DuraLite™ ECC Restriction Curves

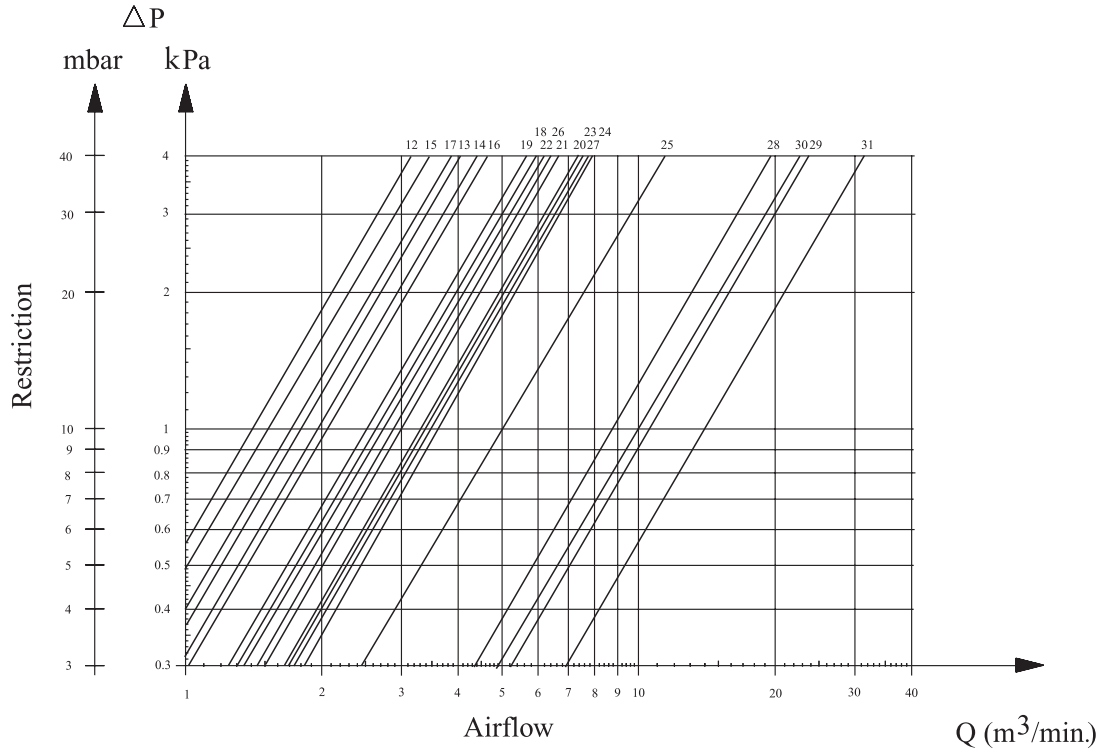

DuraLite™ ECD Restriction Curves

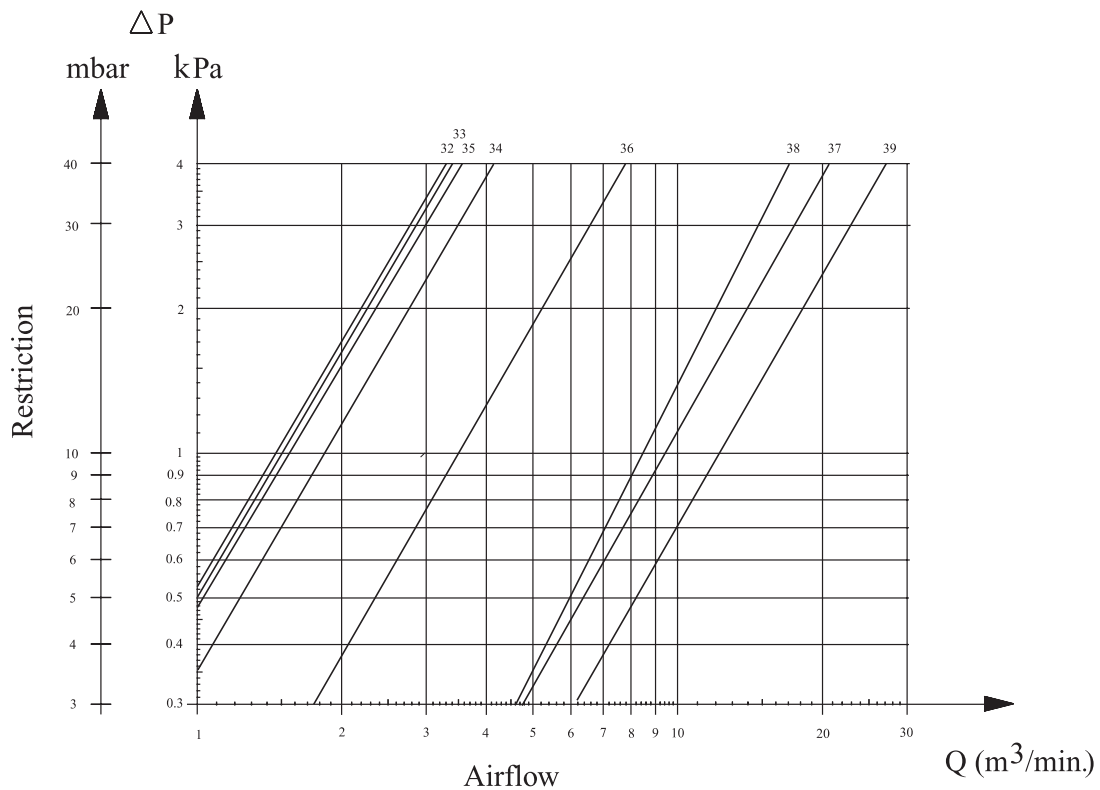

Light Dust Conditions

Service Recommendations

Servicing Intervals

Choose either of two types:

- **Scheduled maintenance.**
DuraLite service intervals can be integrated into any existing maintenance program.
- **Restriction Maintenance.**
This method offers the most accurate filter maintenance program, delivering maximum filter life at 99.9% efficiency, less machine downtime, and reduced maintenance costs.
- **Washing, cleaning or servicing the filter in any way voids the warranty.**

Service Indicator Location

For proper restriction readings, a restriction fitting tap must be located between the engine intake and DuraLite outlet neck. The tap should be located in a straight section of the intake pipe at least one pipe diameter away from the manifold or any bends, elbows or reducers.

Servicing Tips

- Do NOT judge the filter on the basis of visual inspection! If it's doing its job, it should look dirty. DuraLite filter life is longer than you may think. Change the filter only when restriction readings indicate.
- Do NOT leave the inlet ducting exposed any longer than necessary (a few minutes) during service.

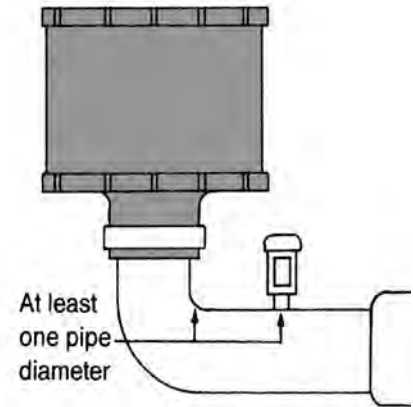

Disposal

Normal trash pick up is acceptable - never burn.

Installation Instructions

Installation

DuraLite air cleaners can be mounted in two ways:

1. **Direct Mount:** mounted directly on the intake manifold.
2. **Remote Mount:** mounted away from engine and connected to engine with inlet piping.

Installation Tips

- Engage outlet neck of the DuraLite™ over intake piping for a full 38 mm to insure a secure, lasting seal.
- Tighten clamp around outlet neck to 0.7 daNm minimum. A Donaldson high torque hose clamp is recommended.
- On remote mount style, avoid crushing the body with body clamps. A snug fit is best, and body clamps are not always required.
- Keep away from engine manifold and other very hot components (DuraLite™ is rated at 83°C maximum sustained temperature).
- Keep away from battery acids, brake fluid, and other caustic fluids.

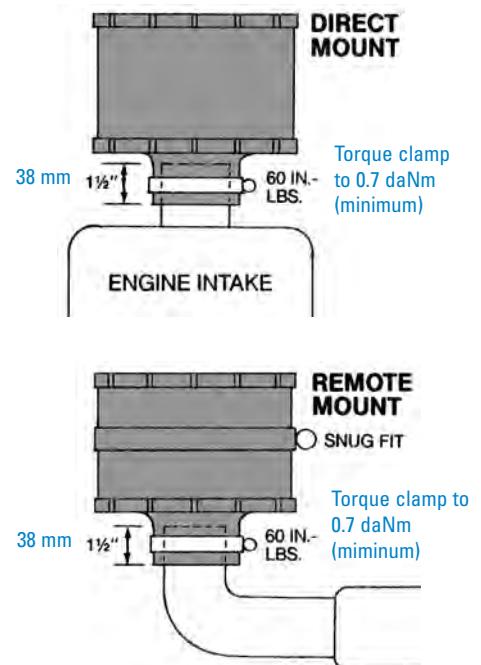

Primary Dry RadialSeal™ Air Cleaners which offer improved reliability and durability, reduced weight and costs and better serviceability.

The EPB-ERB2 Primary Dry RadialSeal™ Air Cleaners are used on light-duty applications like on-highway vehicles, stand-by generator sets and all other light-duty applications. They are also used on medium- and heavy-duty applications but than always combined with a Pre-Cleaner.

For more details on EPB-ERB2 Air Cleaners with Pre-Cleaners operating in Medium Dust conditions see page 60-63 and in Heavy Dust conditions see page 93-96 .



The EPB Air Cleaner is a one-stage full-plastic air cleaner

Built with
Donaldson
Technology.



The ERB2 Air Cleaner is a one-stage hybrid air cleaner. It is the Next Generation ERB Air Cleaner Product featuring Donaldson's Unique Design Concept. For more details on this UDC Feature, see page 7.

Applications EPB-ERB2

- Can be mounted vertically or horizontally
- Provides variety of airflow volumes to engine: from 2 to 65 m³/min.
- Temperature tolerance: to 83°C continuous / 105°C intermittent.

Features EPB-ERB2

- Cost effective / Compact and light
- Flexible installation / Conquers underhood space limitations
- Reliable, durable, high-tech and easy to service design
- Proven RadialSeal™ Technology
- Pre-cleaner can be added / Tapped for restriction indicator as standard
- Filter inside air cleaner is different from filters with metal end caps
- One-piece molded end caps encase the ends of media and filter liners
- Filter fits over the housing outlet tube, creating a reliable seal - with no hassle of separate sealing gaskets
- Indicator thread size = 1/8-27NPT (MALE)

EPB Specifications - Service Parts

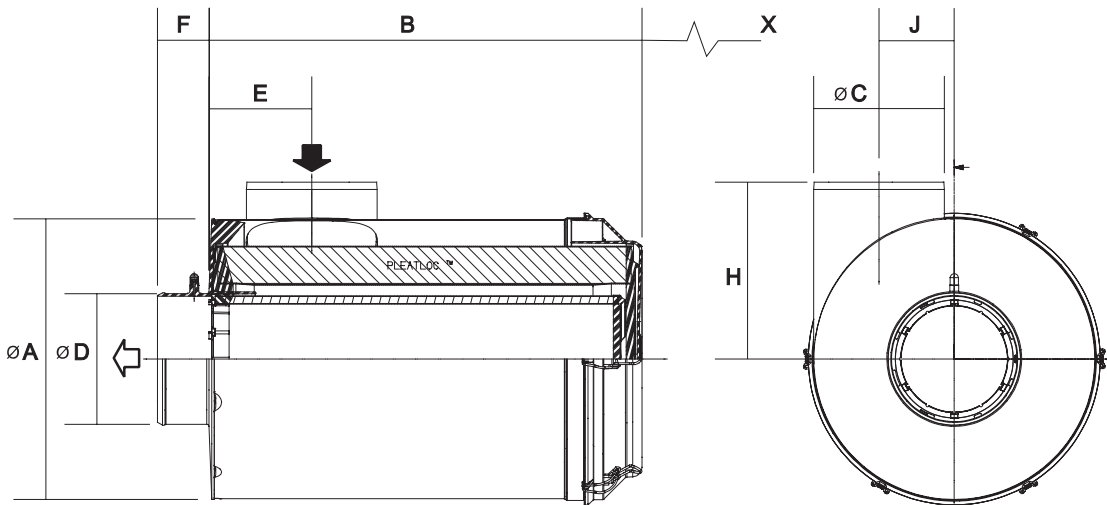

Light Dust Conditions

| Air Cleaner Model No. | Airflow m ³ /min. | Range Dimensions (mm) | | | | | | | | | |
|-----------------------|------------------------------|-----------------------|-----|----|----|----|------|-----|-----|-----|-----|
| | | A | B | C | D | E | F | H | J | X° | Z°° |
| B070005* | 2 - 5 | 182 | 334 | 76 | 76 | 45 | 27 | 115 | 145 | 340 | 45 |
| B080067* | 4 - 7 | 210 | 355 | 95 | 89 | 54 | 31,5 | 130 | 146 | 355 | 110 |

* Includes safety element
 X° Free space needed to remove main element Z°° Free space needed to remove cover

Service Parts

| Air Cleaner Model No. | Main Element | Safety Element | Access Cover Assy* | Raincap | Mounting band** |
|-----------------------|--------------|----------------|--------------------|---------|-----------------|
| B070005 | P772579 | P775300 | P778758 | H001379 | P777731 |
| B080067 | P772580 | P775302 | P775305 | H770010 | P777732 |

* Spare Part only ** Only one mounting band needed per Air Cleaner

ERB2 Specifications - Service Parts

UNIQUE DESIGN CONCEPT

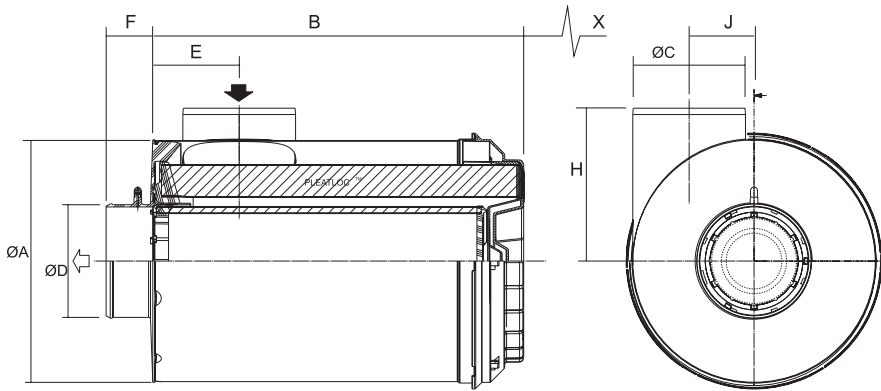

| ERB2 Air Cleaners | ERB |
|----------------------|---------|
| B100126 | B100120 |
| B130057 | B130010 |
| B130058 | B130013 |
| B150058 | B150025 |
| B150059 | B150028 |
| B180016 | B180011 |
| B180017 | B180012 |

| Air Cleaner Model No. | Airflow m ³ /min. | Range Dimensions (mm) | | | | | | | | | |
|-----------------------|------------------------------|-----------------------|-----|-----|-----|-----|----|-----|-----|-----|-----|
| | | A | B | C | D | E | F | H | J | X° | Z° |
| B100126* | 8 - 14 | 259 | 430 | 114 | 102 | 143 | 52 | 205 | 0 | 400 | 75 |
| B130057 | 18 - 30 | 330 | 530 | 178 | 152 | 180 | 58 | 215 | 0 | 360 | 95 |
| B130058* | 18 - 28 | 330 | 530 | 178 | 152 | 180 | 58 | 215 | 0 | 360 | 95 |
| B150058* | 18 - 32 | 381 | 590 | 178 | 178 | 136 | 70 | 241 | 102 | 540 | 93 |
| B150059 | 18 - 32 | 381 | 590 | 178 | 178 | 136 | 70 | 241 | 102 | 540 | 93 |
| B180016 | 32 - 65 | 457 | 650 | 254 | 203 | 282 | 85 | 328 | 0 | 600 | 130 |
| B180017* | 32 - 65 | 457 | 650 | 254 | 203 | 282 | 85 | 328 | 0 | 600 | 130 |

* Includes safety element X° Free space needed to remove main element Z° Free space needed to remove cover

Service Parts

| ERB2 Air Cleaner | Main Element | Kit Number • | Access Cover Assy* | Raincap | Mounting band** |
|------------------|--------------|--------------|--------------------|---------|-----------------|
| B100126 | P785388 | X770685 | P784954 | H770012 | P004076 |
| B130057 | P785610 | - | P783693 | H770089 | P013722 |
| B130058 | P785610 | X770686 | P783693 | H770089 | P013722 |
| B150058 | P785426 | X770687 | P784869 | H770089 | P016845 |
| B150059 | P785426 | - | P784869 | H770089 | P016845 |
| B180016 | P785394 | - | P785546 | H770082 | H770037 |
| B180017 | P785394 | X770688 | P785546 | H770082 | H770037 |

* Spare Part only ** Two mounting bands needed per Air Cleaner
 • Safety element can only be bought as a kit meaning together with the main element

Light Dust Conditions

When specifying an Air Cleaner...

Determine the Airflow Requirements of your engine, then find the corresponding m³/min. airflow in the charts below. The restriction numbers - shown in mbar at the left side of the chart - indicate the approximate initial restriction of each model air cleaner at that m³/min. When calculating total initial restriction of the entire air intake system, include the restriction caused by ducting, elbows, pre-cleaners, etc. The estimated lab life hours are indicated at the right side of the chart.

EPB Performance Curves

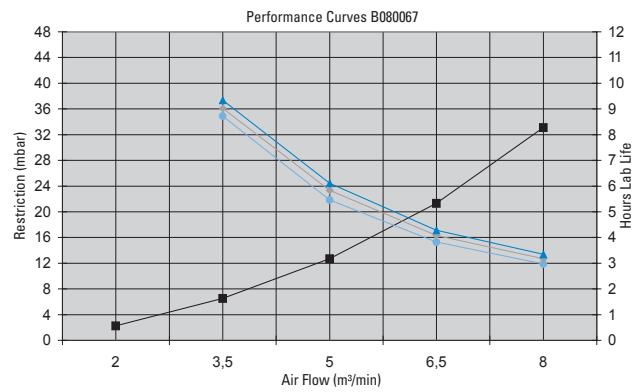
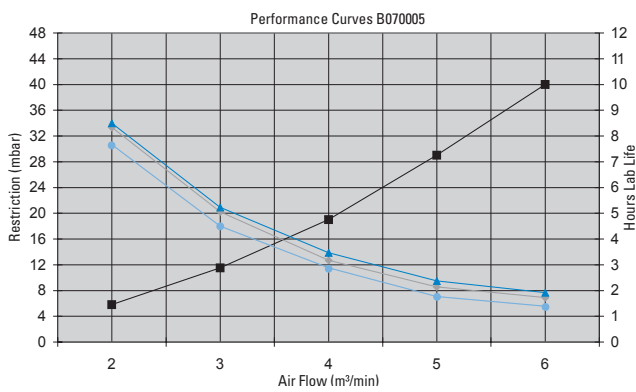

ERB2 Performance Curves

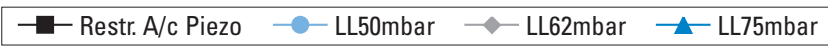
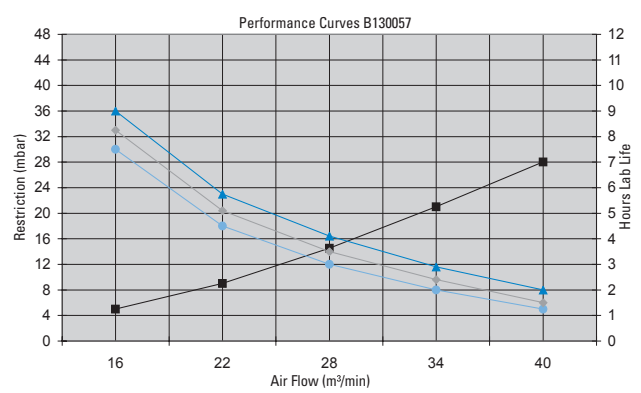
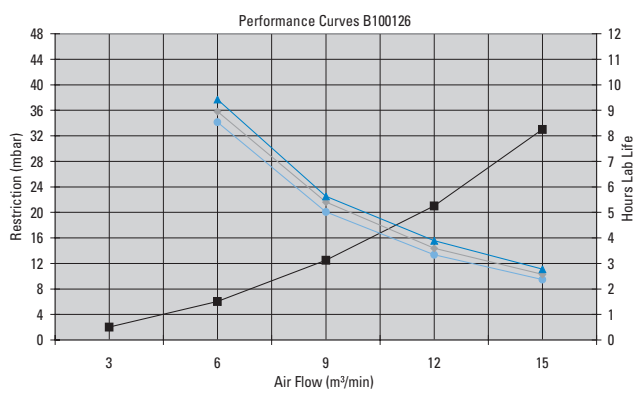

All performance curves are according ISO 5011 standards - Restriction measured at Piezo
 All tests are done with ISO Coarse at Dust Concentration of 1g/m³

Light Dust Conditions

ERB2 Performance Curves

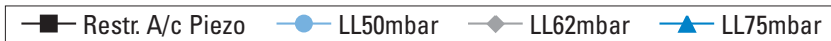
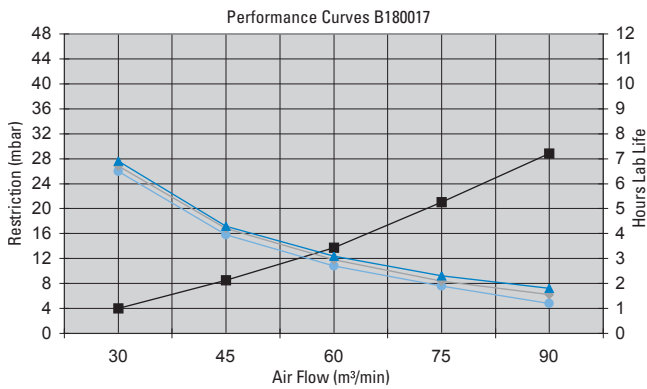
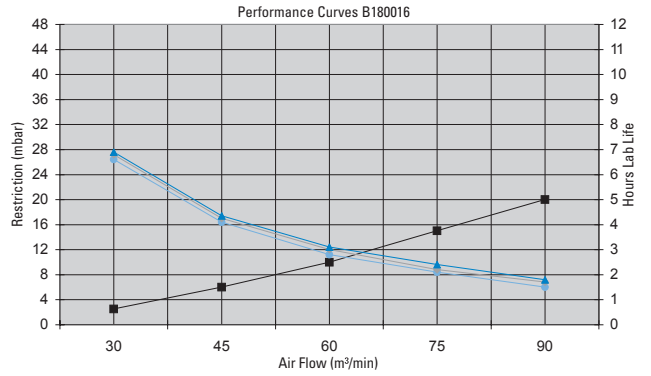
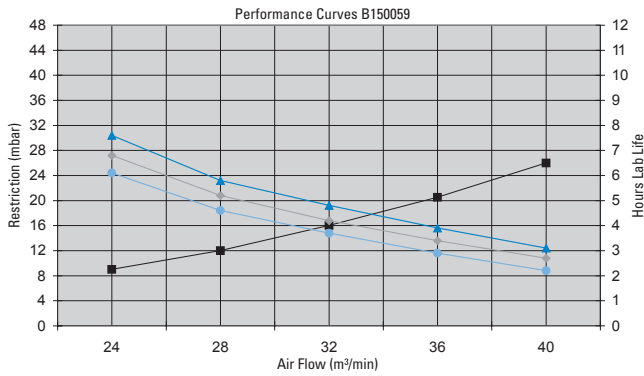
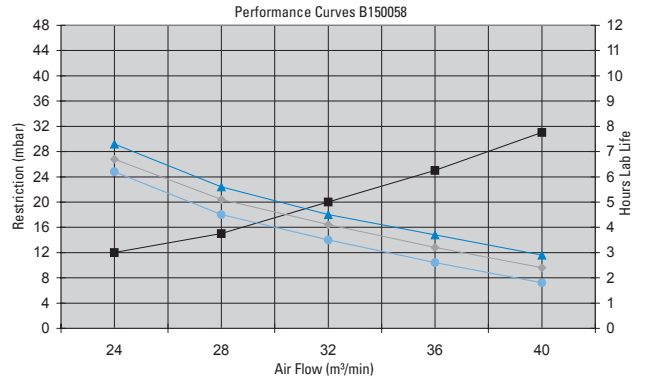
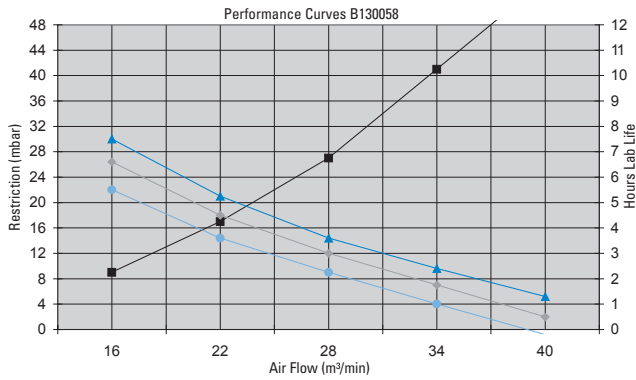

All performance curves are according ISO 5011 standards - Restriction measured at Piezo
All tests are done with ISO Coarse at Dust Concentration of 1g/m³

1 Remove the Filter

Unfasten or unlatch the service cover.



Rotate the filter while pulling straight out.

Because the filter fits tightly over the outlet tube to create the critical seal, there will be some initial resistance, similar to breaking the seal on a jar. Gently move the end of the filter back and forth to break the seal then rotate while pulling straight out. Avoid knocking the filter against the housing.



If your air cleaner has a safety filter, replace it every third primary filter change. Remove the safety filter as you would the primary filter. Make sure you cover the air cleaner outlet tube to avoid any unfiltered contaminant dropping into the engine.

2 Clean Both Surfaces of the Outlet Tube and Check the Vacuator™ Valve

Use a clean cloth to wipe the filter sealing surface and the inside of the outlet tube. Contaminant on the sealing surface could hinder an effective seal and cause leakage. Make sure that all contaminant is removed before the new filter is inserted. Dirt accidentally transferred to the inside of the outlet tube will reach the engine and cause wear. Engine manufacturers say that it takes only a few grams of dirt to “dust” an engine! Be careful not to damage the sealing area on the tube.

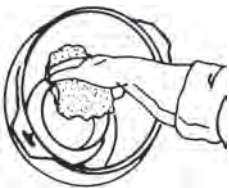

Outer edge of the outlet tube

Wipe both sides of the outlet tube clean.



Inner edge of the outlet tube

If your air cleaner is equipped with a Vacuator Valve

Visually check and physically squeeze to make sure the valve is flexible and not inverted, damaged or plugged.



3 Inspect the Old Filter for Leak Clues

Visually inspect the old filter for any signs of leaks. A streak of dust on the clean side of the filter is a telltale sign. Remove any cause of leaks before installing new filter.

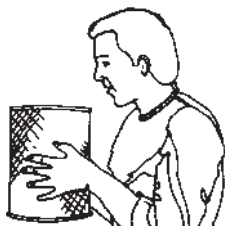

4 Inspect the New Filter for Damage

Inspect the new filter carefully, paying attention to the inside of the open end, which is the sealing area. NEVER install a damaged filter. A new Donaldson radial seal filter may have a dry lubricant on the seal to aid installation.

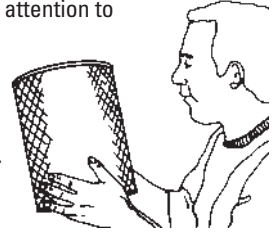

5 Insert the New Radial Seal Filter Properly

If you're servicing the safety filter, this should be seated into position before installing the primary filter.

Insert the new filter carefully. Seat the filter by hand, making certain it is completely into the air cleaner housing before securing the cover in place.



The critical sealing area will stretch slightly, adjust itself and distribute the sealing pressure evenly. To complete a tight seal, apply pressure by hand at the outer rim of the filter, not the flexible center. Avoid pushing on the center of the urethane end cap. No cover pressure is required to hold the seal. NEVER use the service cover to push the filter into place! Using the cover to push the filter in could cause damage to the housing, cover fasteners and will void the warranty.

If the service cover hits the filter before it is fully in place, remove the cover and push the filter (by hand) further into the air cleaner and try again. The cover should go on with no extra force.

Once the filter is in place, secure the service cover.

Caution

NEVER use the service cover to push the filter into place! Using the cover to push the filter in could cause damage to the housing, cover fasteners and will void the warranty.



6 Check Connectors for Tight Fit

Make sure that all mounting bands, clamps, bolts, and connections in the entire air cleaner system are tight. Check for holes in piping and repair if needed. Any leaks in your intake piping will send dust directly to the engine!

Air Cleaners used in Medium Dust Conditions

... Donaldson offers a full line of air cleaners for a wide variety of applications and operating environments.

Section Index

| | |
|--|----|
| FKB | 50 |
| FKB Service Instructions..... | 54 |
| XRB | 55 |
| XRB Service Instructions | 59 |
| EPB-ERB2 with Full-View Pre-Cleaner | 60 |
| EPB-ERB2 with TopSpin™ Pre-Cleaner | 62 |
| FPG | 64 |
| FPG Alexin™ | 70 |
| FPG + FPG Alexin Service Instructions..... | 76 |
| FPG + FPG Alexin Mounting Bands..... | 77 |
| FTG Cycloflow™ | 78 |
| FTG Service Instructions..... | 81 |
| FRG2 | 82 |
| FRG2 Service Instructions..... | 88 |

**UNIQUE
DESIGN
CONCEPT**

**UNIQUE
DESIGN
CONCEPT**

Smaller, Lightweight Alternative Two-Stage Air Cleaner Designed for horizontal installation

The FKB series is a family of two-stage air cleaners for medium dust conditions.

Compared to other air cleaner styles, this new air cleaner family delivers the performance of competitive larger air cleaners in a compact, rugged design.

With heavy-duty plastic construction and non-metal filters, the air cleaner is lighter, more efficient and easier to install and replace than competing products.

Another key design feature is the built-in mounting brackets. There's no need for additional mounting support.

The two stage design features a built-in pre-cleaner that separates up to 85% of airborne contaminants.



The FKB's plastic housing and durable construction enables installation in all types of medium-dust environments with engine air flow from 2 - 10 m³/min.

FKB air cleaners effectively reduce contaminants flowing into the air intake system, provide a

high level of engine protection from harmful contaminants and increase engine performance and fuel efficiency.

The air cleaner models ship with both the main and safety filters.



Built-in Mounting Brackets and Filter Indicator Port Easy to service with non-metal filters

Applications

- Off-road equipment operating in medium-dust conditions with engine airflow range of 2 to 10 m³/min.
- Installs horizontally. In case engine mount is required, contact Donaldson Representative.
- Sustained temperature tolerance: to 82°C. Do not install next to components that exceed the maximum temperature (82°C); like a turbocharger, muffler, exhaust pipe or other high temperature component

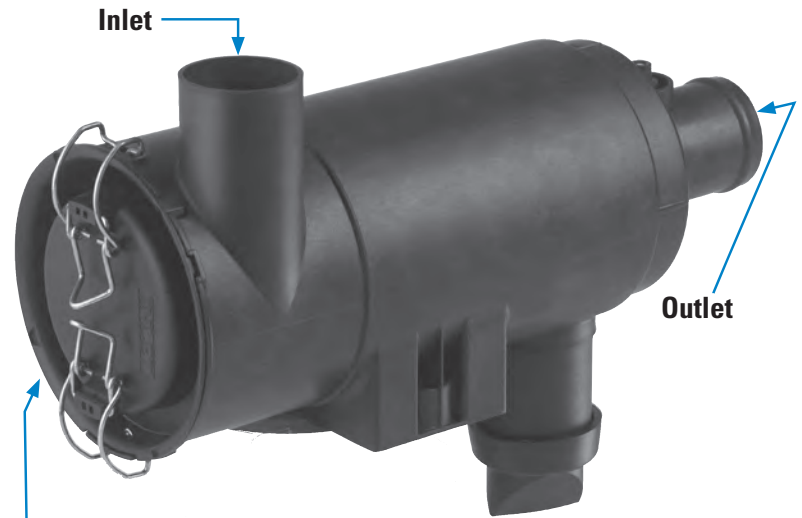

Filter changeout is a snap with minimal service clearance required

Air Cleaner Features

- Smaller in diameter compared to competitive brands with similar airflow
- Improved handling and maintenance: lighter and smaller, changing filters is a snap
- Product design includes:
 - main filter
 - safety filter
 - filter service indicator port
- Improved filter disposal ease: no metal
- Cover latch position allows for minimum service clearance and eases filter service
- Mounting brackets built-in to air cleaner body eliminating need for mounting bands
- Indicator thread size = 1/8-27NPT (MALE)



Unique Twist & Lock Filter ensure proper positioning during filter service. Air cleaners assemblies include main and safety filters.

FKB Specifications - Service Parts

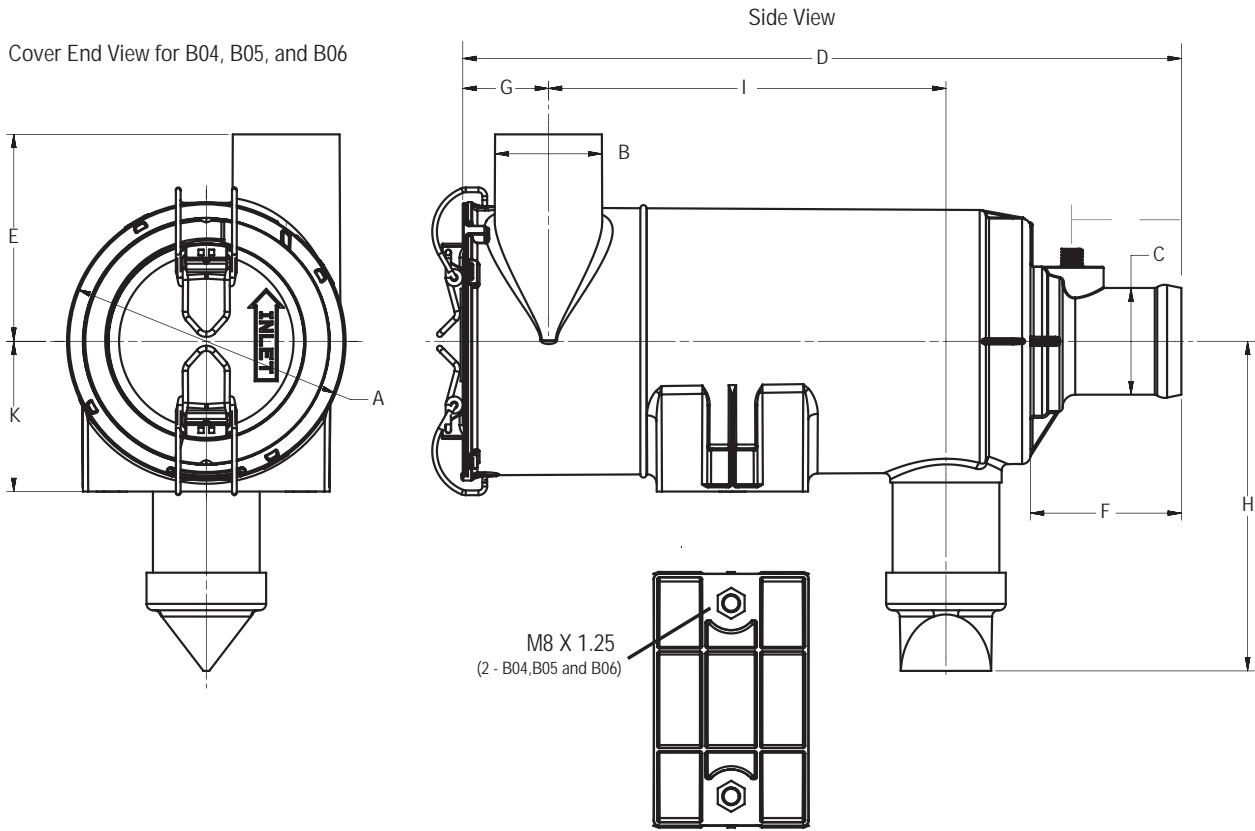

| Air Cleaner Model No. | Airflow m ³ /min. | Range Dimensions (mm) | | | | | | | | | | |
|-----------------------|------------------------------|-----------------------|----|----|-----|-----|----|----|-----|-----|----|----|
| | | A | B | C | D | E | F | G | H | I | J | K |
| B045008 | 2 - 3 | 133 | 51 | 51 | 342 | 99 | 72 | 41 | 157 | 189 | 52 | 72 |
| B055006 | 3 - 4 | 152 | 64 | 64 | 404 | 99 | 73 | 49 | 157 | 244 | 52 | 77 |
| B065045 | 4 - 6 | 180 | 76 | 76 | 408 | 120 | 73 | 53 | 188 | 241 | 52 | 90 |

Service Parts

| Air Cleaner Model No. | Main Element | Safety Element | Access Cover Assy | Vacuator™ Valve |
|-----------------------|--------------|----------------|-------------------|-----------------|
| B045008 | P604457 | P603729 | P606497 | P158914 |
| B055006 | P609218 | P602427 | P609219 | P158914 |
| B065045 | P609221 | P608599 | P608592 | P158914 |

Medium Dust Conditions

When specifying an Air Cleaner...

Determine the Airflow Requirements of your engine, then find the corresponding m³/min. airflow in the charts below. The restriction numbers - shown in mbar at the left side of the chart - indicate the approximate initial restriction of each model air cleaner at that m³/min. When calculating total initial restriction of the entire air intake system, include the restriction caused by ducting, elbows, pre-cleaners, etc. The estimated lab life hours are indicated at the right side of the chart.

FKB Performance Curves

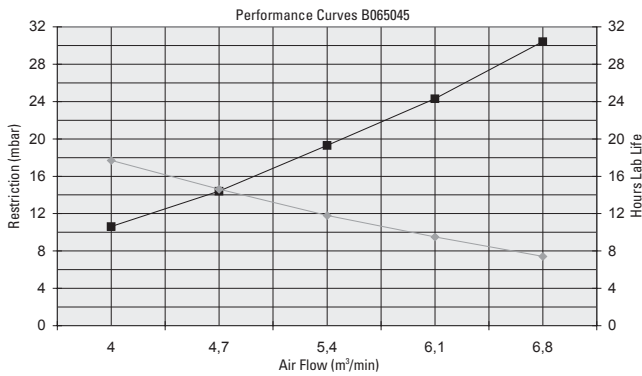
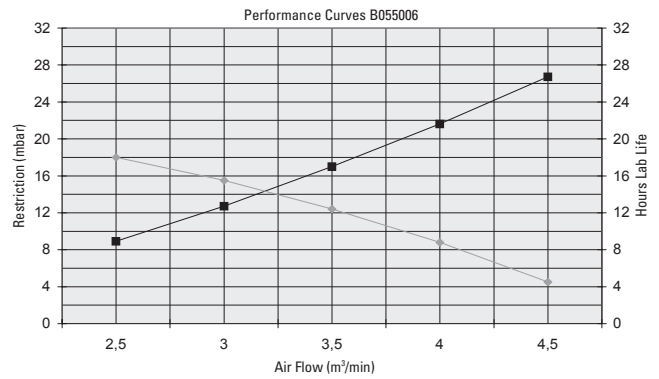
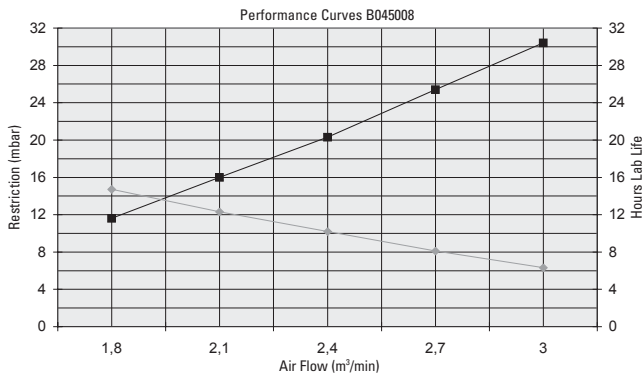

All performance curves are according ISO 5011 standards - Restriction measured at Piezo
 All tests are done with ISO Coarse at Dust Concentration of 1g/m³

Installation Recommendations

- Shut off your engine.
- Air cleaner orientation is horizontal, with the drop tube pointing down - within +/- 15°. For service clearance, allow the entire length of the filter for removal and 35mm for service cover latches.
- Mounting is M8 x 1,25 with a maximum torque of 20,34 Nm.
- Connections: Inlet/Outlet maximum torque 4,52 Nm Indicator port maximum torque 2 Nm.
- Inlet accessory note: The air cleaner housing can accommodate a lightweight inlet hood, but not a pre-cleaner or any other accessory. Use of an unapproved intake accessory will void your Donaldson warranty.

Service Instructions

1 Shut off your engine

2 Remove service cover

Unlatch and remove the service cover. To remove the primary filter, press and rotate filter counterclockwise until filter is free.

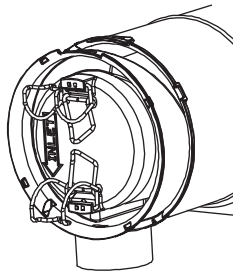

3 Remove the filter

Gently pull the filter out of housing. Avoid dislodging contaminant from the filter or knocking it against the housing.

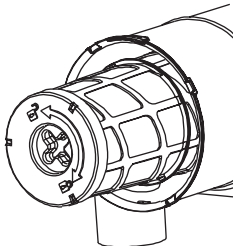

4 Clean the inside surface

With a soft rag, thoroughly clean the inside surface of the housing. Be careful not to introduce contaminant into the outlet tube.

5 Check the safety filter

Check safety filter for damage. If damaged, replace. Also check to insure that the safety filter is properly seated in the housing. It should fit snugly inside the outlet tube.

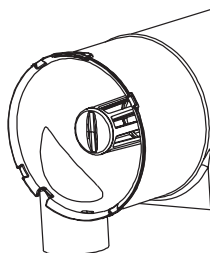

6 Inspect the new primary filter

Inspect the new main filter carefully. Check for any voids, cuts, tears or indentations in the urethane-sealing surfaces.

7 Install the new filter

Install new filter by pressing and rotating the filter clockwise until fully engaged to stop.

8 Replace the cover

Replace the service cover. The "INLET" arrow should line up with the air cleaner inlet. DO NOT force cover onto air cleaner. The cover should go on with no extra force. If cover is not flush to the body, the filter is not properly seated in the housing.

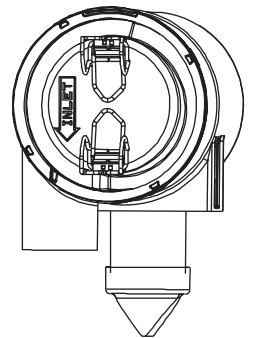

9 Refasten the latches

Refasten latches to secure cover. Make sure that latches penetrate the slots in both the body and the cover.

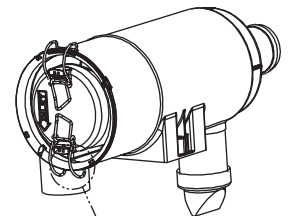

10 Inspect

Inspect and torque all clamps, bolts and connections in the entire air intake system. Check for holes in piping, and repair if needed. If Vacuator Valve is damaged replace.

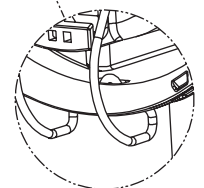

11 Restart the engine

Compact, Radial Seal, Medium-Duty Air Cleaner Designed for horizontal installation

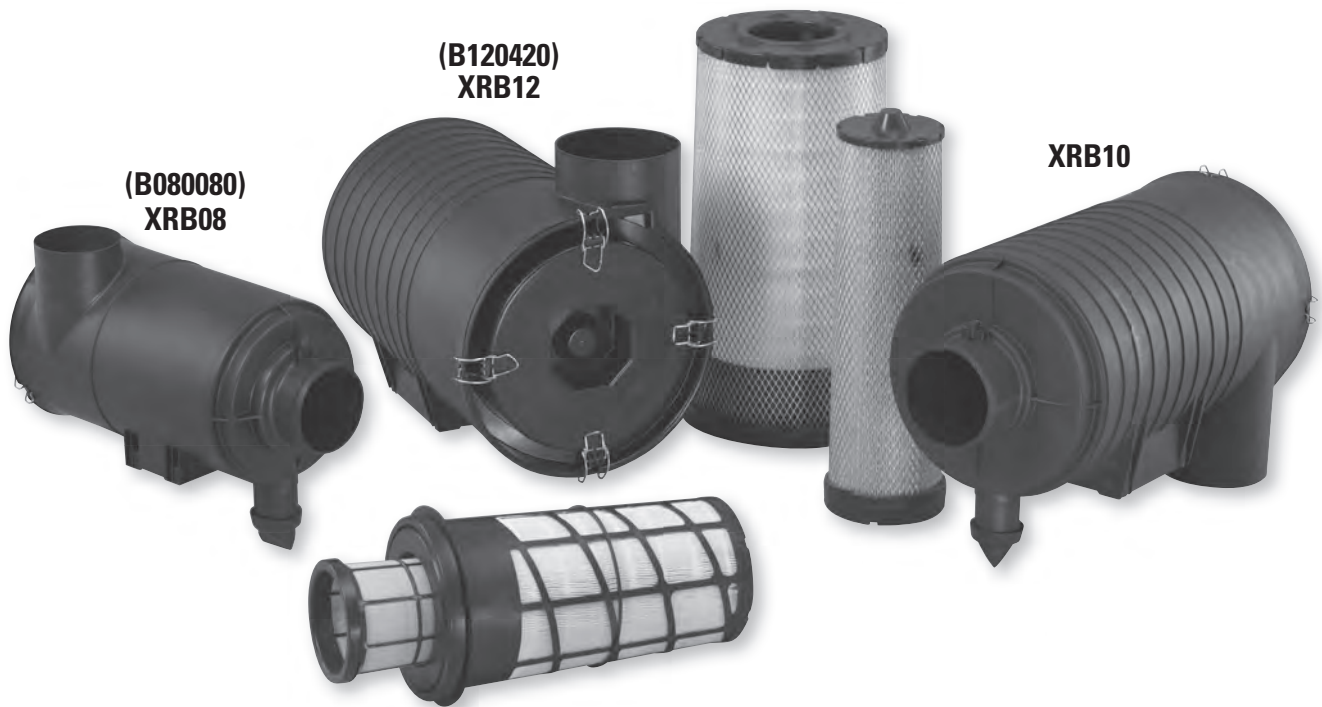

Compared to other air cleaner styles, this new air cleaner family is smaller in size compared to competitive models with similar airflow operating ranges.

XRB air cleaners effectively reduce contaminants flowing into the air intake system, provide a high level of engine protection from harmful contaminants and increase engine performance and fuel efficiency.

The XRB's plastic housing and durable construction enables installation in medium-dust environments with engine airflow from 7,5 to 18 m³/min.

The B080080 has non-metal main and safety filters. The main filters for the B100127 and B120420 have metal outer liners. The air cleaner models ship with both the main and safety filters.

Like our FKB and PSD models, these air cleaners feature built-in mounting brackets. There's no need for additional mounting support.

Built-in Mounting Brackets and Filter Indicator Port Easy to service with non-metal filters

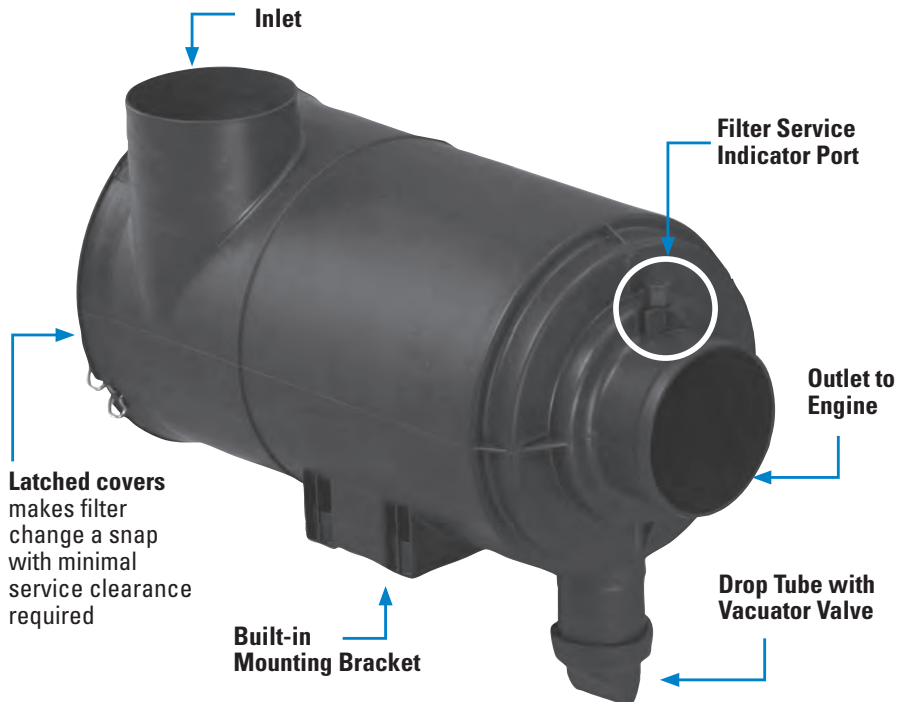

Applications

- Off-road equipment operating in medium-dust conditions with engine airflow range of 7,5 to 18 m³/min.
- Installs horizontally. In case engine mount is required contact your Donaldson Representative.
- Sustained temperature tolerance: to 82°C. Do not install next to components that exceed the maximum temperature (82°C); like a turbocharger, muffler, exhaust pipe or other high temperature component

Air Cleaner Features

- Smaller in diameter compared to competitive brands with similar airflow
- Improved handling and maintenance: lighter and smaller, changing filters is a snap
- Product design includes:
 - main filter
 - safety filter
 - filter service indicator port
- Cover latch position allows for minimum service clearance and eases filter service
- Mounting brackets built-in to air cleaner body eliminating need for mounting bands
- Indicator thread size = 1/8-27NPT (MALE)

XRB Specifications - Service Parts

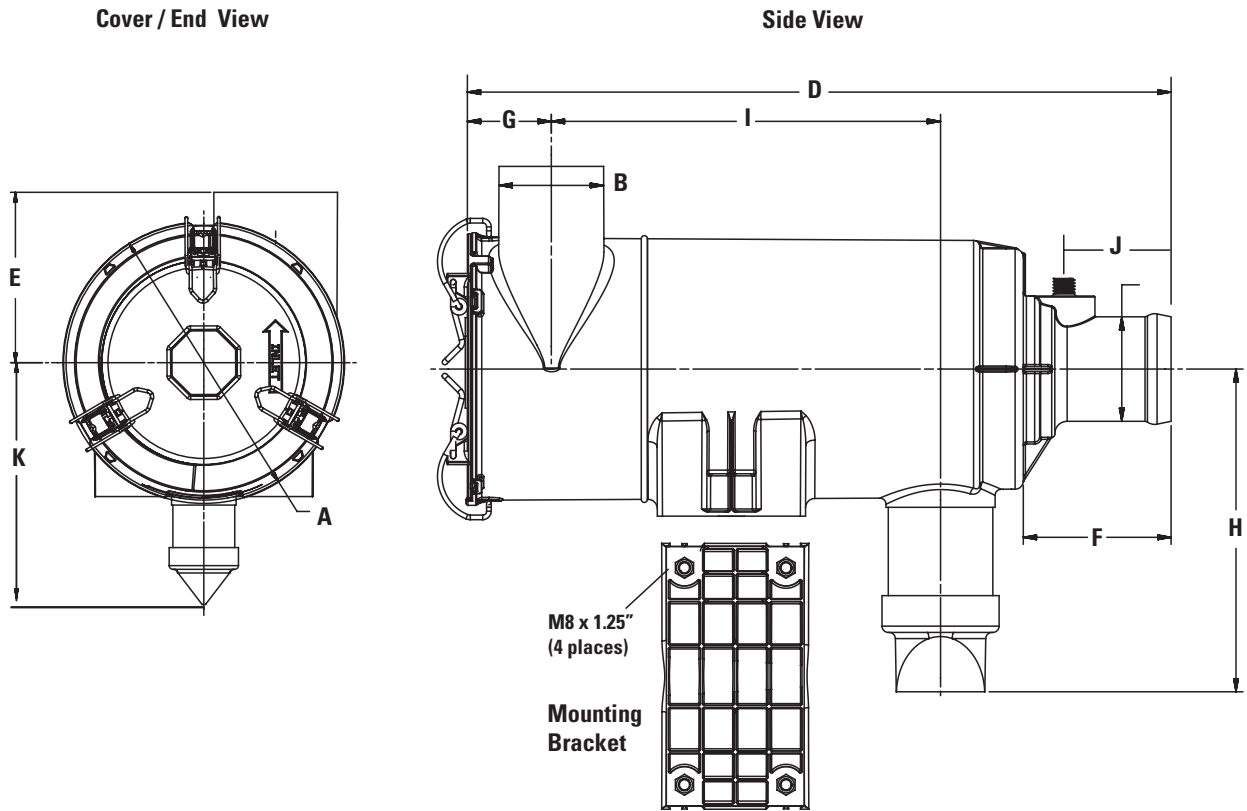

| Air Cleaner Model No. | Airflow m ³ /min. | Range Dimensions (mm) | | | | | | | | | | |
|-----------------------|------------------------------|-----------------------|-----|-----|-----|-----|----|-----|-----|-----|----|-----|
| | | A | B | C | D | E | F | G | H | I | J | K |
| B080080 | 7,5 - 10 | 231 | 102 | 102 | 425 | 140 | 61 | 80 | 198 | 375 | 40 | 110 |
| B100127 | 9 - 13,5 | 287 | 127 | 114 | 565 | 198 | 72 | 88 | 225 | 493 | 50 | 145 |
| B120470 | 13,5 - 18 | 330 | 152 | 128 | 601 | 218 | 71 | 100 | 245 | 526 | 50 | 165 |

| Air Cleaner Model No. | Service Parts | | | |
|-----------------------|---------------|----------------|-------------------|-----------------|
| | Main Element | Safety Element | Access Cover Assy | Vacuator™ Valve |
| B080080 | P611190 • | P611189 | P605731 | P158914 |
| B100127 | P611539 * | P611540 | P609942 | P158914 |
| B120470 | P608116 * | P608391 | P608117 | P158914 |

• Non Metal * Metal Liner

When specifying an Air Cleaner...

Determine the Airflow Requirements of your engine, then find the corresponding m^3/min airflow in the charts below. The restriction numbers - shown in mbar at the left side of the chart - indicate the approximate initial restriction of each model air cleaner at that m^3/min . When calculating total initial restriction of the entire air intake system, include the restriction caused by ducting, elbows, pre-cleaners, etc. The estimated lab life hours are indicated at the right side of the chart.

XRB Performance Curves

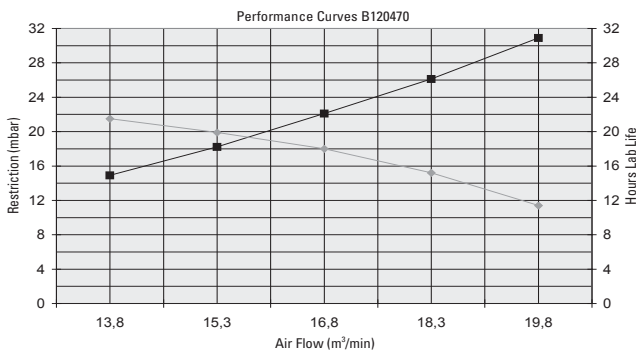
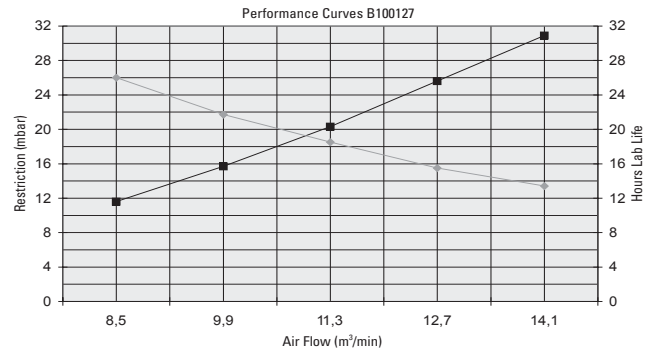
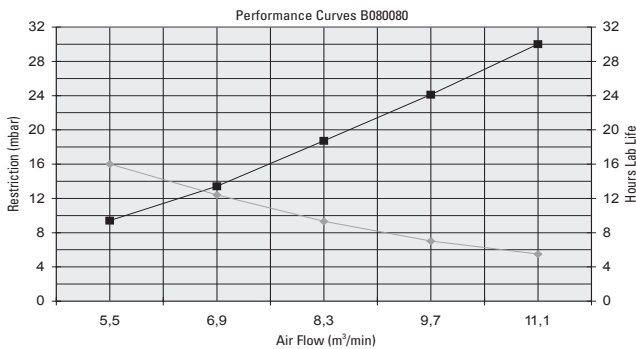

All performance curves are according ISO 5011 standards - Restriction measured at Piezo
All tests are done with ISO Coarse at Dust Concentration of $1g/m^3$

Installation Recommendations

- Air cleaner orientation is horizontal, with the drop tube pointing down - within +/- 15°. For service clearance, allow the entire length of the filter for removal and 35 mm for service cover latches.
- Mounting is M8 x 1,25 with a maximum torque of 20,34 Nm.
- Connections: Inlet/Outlet maximum torque 4.52 Nm.
- Inlet accessory note: The air cleaner housing can accommodate a lightweight inlet hood, but not a pre-cleaner or any other accessory. Use of an unapproved intake accessory will void your Donaldson warranty.
- Filter Service Indicator port arrives with plug/cap. Order filter service indicator separately. See accessories section. Indicator port maximum torque 2 Nm.

1 Shut off your engine

2 Unlatch and remove service cover

Unlatch and remove the service cover to access the main filter. Gently move the end of the filter back and forth to break the seal.

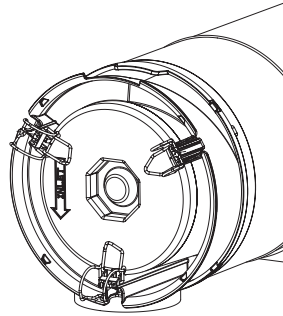

3 Remove the filter

The main filter makes such a tight seal, that you will encounter some initial resistance when trying to remove it. To break the seal, grab the end of the filter and gently move the filter back and forth and pull it out of the housing.

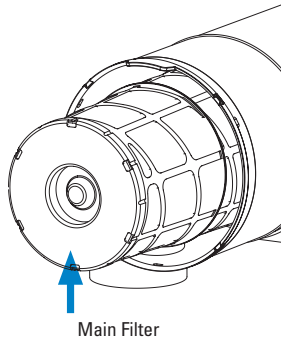

APPLICATION NOTE Avoid dislodging contaminant from the filter or knocking it against the housing.

4 Clean the inside surface

Using a soft rag, remove all the dust and debris from the inside surface of the housing. Be careful not to introduce contaminant into the outlet tube.

APPLICATION NOTE Failure to do so may cause contaminant to be introduced to the seal area of the main filter during reinstallation, causing a leak. Leaks result in higher restriction on the safety filter and shorter filter life.

5 Check the safety filter. Replace every third primary filter change

The safety filter should be changed every third primary filter change out.

APPLICATION NOTE If the safety is not installed properly, it may attach itself to the primary filter upon removal.

Dust from the main filter may be evident on the safety filter. This is normal. At each 1st and 2nd primary filter change, check safety filter for damage. If damaged, replace.

Also check to ensure the safety filter is properly seated in the housing. It should fit snugly inside the outlet tube. Continue pushing the filter into the outlet tube until it stops.

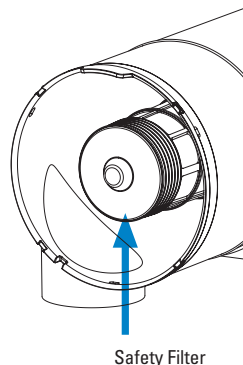

6 Inspect the new main filter

Before installing a new main or safety filter, inspect it carefully. Visually check for any voids, cuts, tears or indentations in the urethane-sealing surface. If your check reveals damage, do NOT install the filter.

7 Install the new filter

The critical sealing area will compress slightly, adjust itself and distribute the sealing pressure evenly. To complete a tight seal, apply pressure by hand at the outer rim of the filter, not the center.

8 Replace the cover & refasten the latches

Replace the service cover. The "INLET" arrow should line up with the air cleaner inlet. DO NOT force cover onto air cleaner. The cover should go on with no extra force.

If cover is not flush to the body, the filter is not properly seated in the housing.

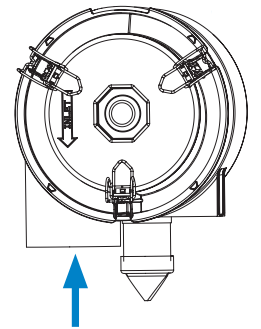

APPLICATION NOTE Never use the service cover to push the filter into place! Using the cover to push the filter could cause damage to the housing and will void the warranty.

If the service cover hits the filter before it is fully in place, remove the cover and push the filter further into the housing and try again. The cover should go on with no extra force.

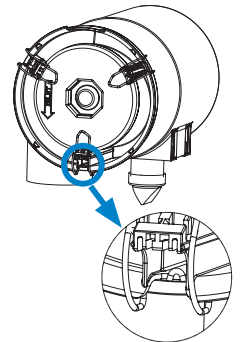

Refasten latches to secure cover. Make sure that latches penetrate the slots in both the body and the cover.

9 Inspect the intake system

Inspect and torque all clamps, bolts and connections in the entire air intake system. Check for holes in piping, and repair if needed. If the Vacuator™ Valve is damaged, replace.

10 Restart your engine

Recommended Main Filter Change Interval

Change the main filter when the restriction level reaches your vehicle/engine manufacturer recommendation.

EPB - ERB2 Air Cleaner with Full-View Pre-Cleaner

Specifications



See page 131 for the Full-View Pre-Cleaners



See page 44-45 for EPB-ERB2 Service Parts

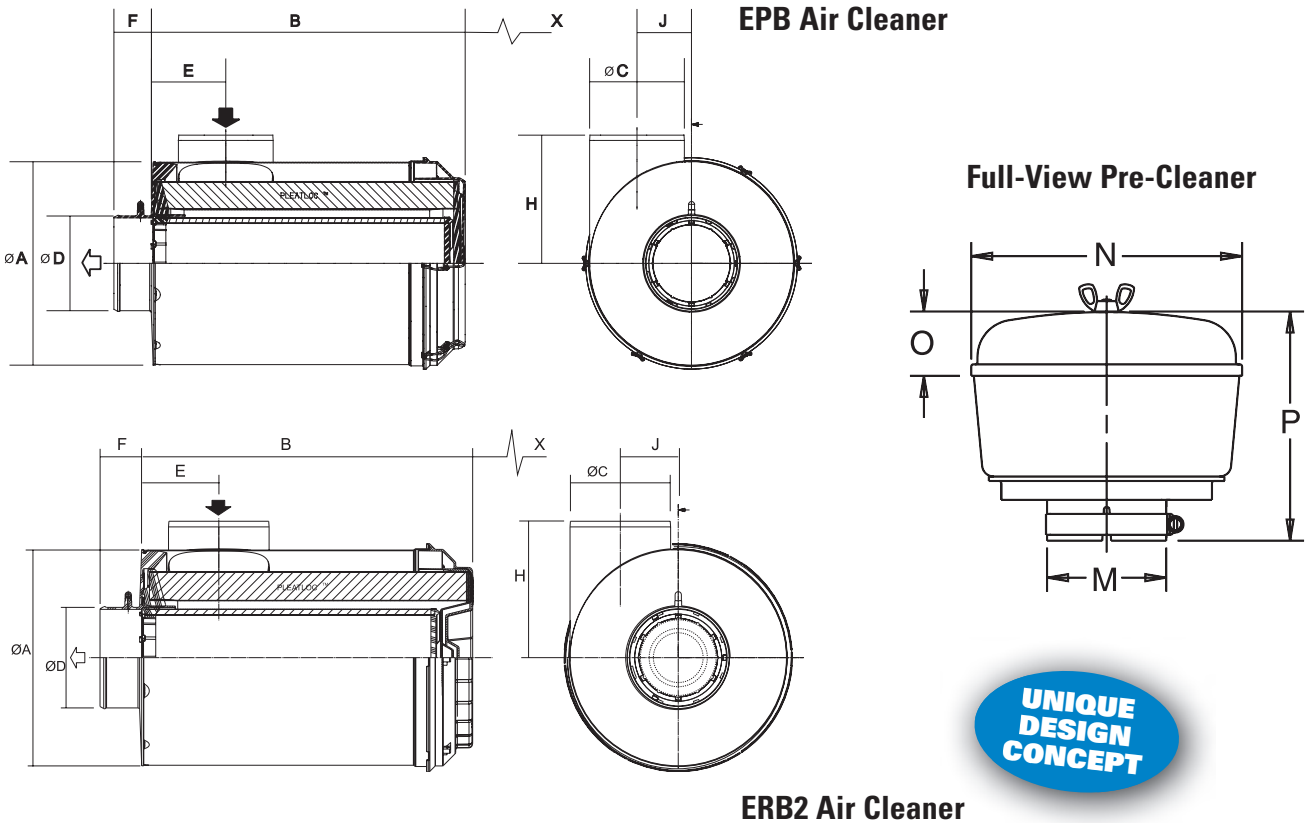

Medium Dust Conditions

| Style | Air Cleaner Model No. | Airflow Range m ³ /min. | Dimensions (mm) | | | | | | | | | Pre-Cleaner | M | N | O | P |
|-------|-----------------------|------------------------------------|-----------------|-----|-----|-----|-----|------|-----|-----|-----|-------------|-----|-----|----|-----|
| | | | A | B | C | D | E | F | H | J | X° | | | | | |
| EPB | B070005 | 2 - 4 | 182 | 334 | 76 | 76 | 45 | 27 | 115 | 145 | 340 | H001249 | 77 | 187 | 42 | 158 |
| EPB | B080067 | 4 - 7 | 210 | 355 | 95 | 89 | 54 | 31,5 | 130 | 146 | 355 | H000821 | 96 | 270 | 47 | 188 |
| ERB2 | B100126 | 7 - 12 | 259 | 430 | 114 | 102 | 143 | 52 | 205 | 0 | 400 | H000823 | 115 | 270 | 47 | 188 |
| ERB2 | B130058 | 15 - 26 | 330 | 530 | 178 | 152 | 180 | 58 | 215 | 0 | 360 | H002224 | 179 | 412 | 69 | 258 |
| ERB2 | B150058 | 18 - 32 | 381 | 590 | 178 | 178 | 136 | 70 | 241 | 102 | 540 | H002224 | 179 | 412 | 69 | 258 |

X ° Free space needed to remove main element

When specifying an Air Cleaner...

Determine the Airflow Requirements of your engine, then find the corresponding m³/min. airflow in the charts below. The restriction numbers - shown in mbar - indicate the approximate initial restriction of each model air cleaner at that m³/min. If there are two air cleaner models that fit your parameters, choosing the one with the lowest restriction will provide the longest service life. When calculating total initial restriction of the entire air intake system, include the restriction caused by ducting, elbows, pre-cleaners, etc.

Restriction Curves

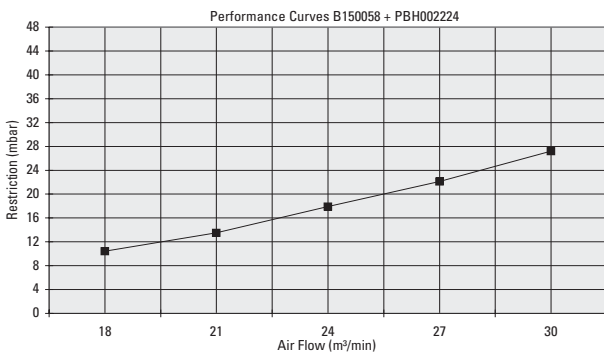
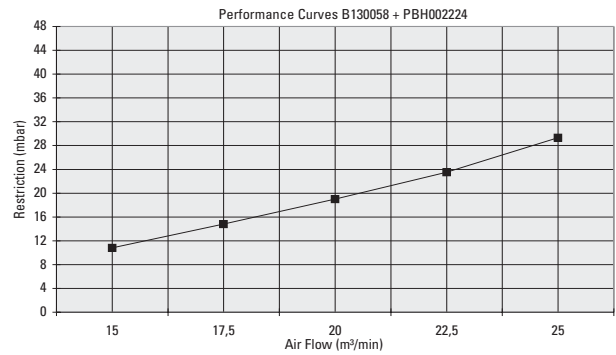
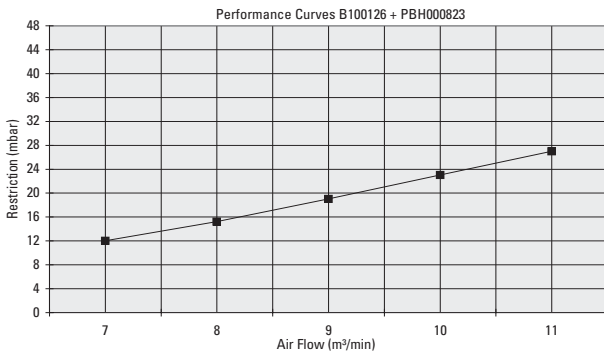
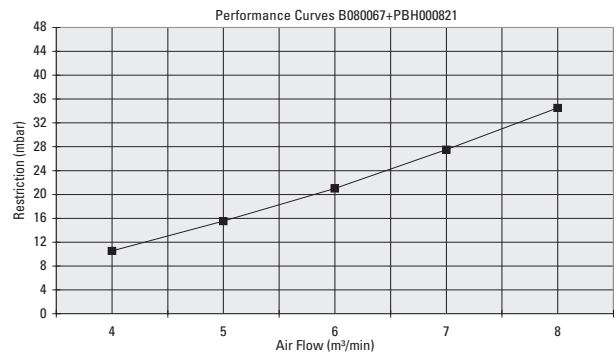
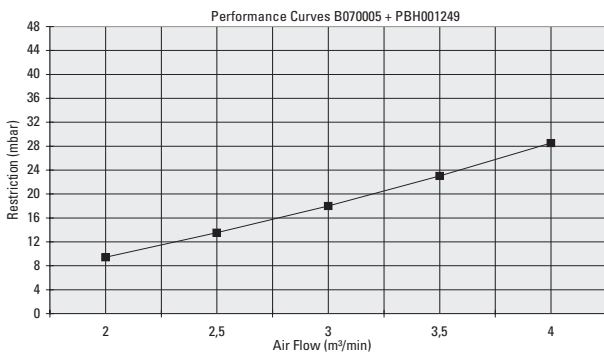

—■— Restr. A/c Piezo

All performance curves are according ISO 5011 standards - Restriction measured at Piezo
All tests are done with ISO Coarse at Dust Concentration of 1g/m³

EPB - ERB2 Air Cleaner with TopSpin™ Pre-Cleaner



Specifications



See page 132-133 for the TopSpin™ Pre-Cleaners



See page 44-45 for EPB-ERB2 Service Parts.

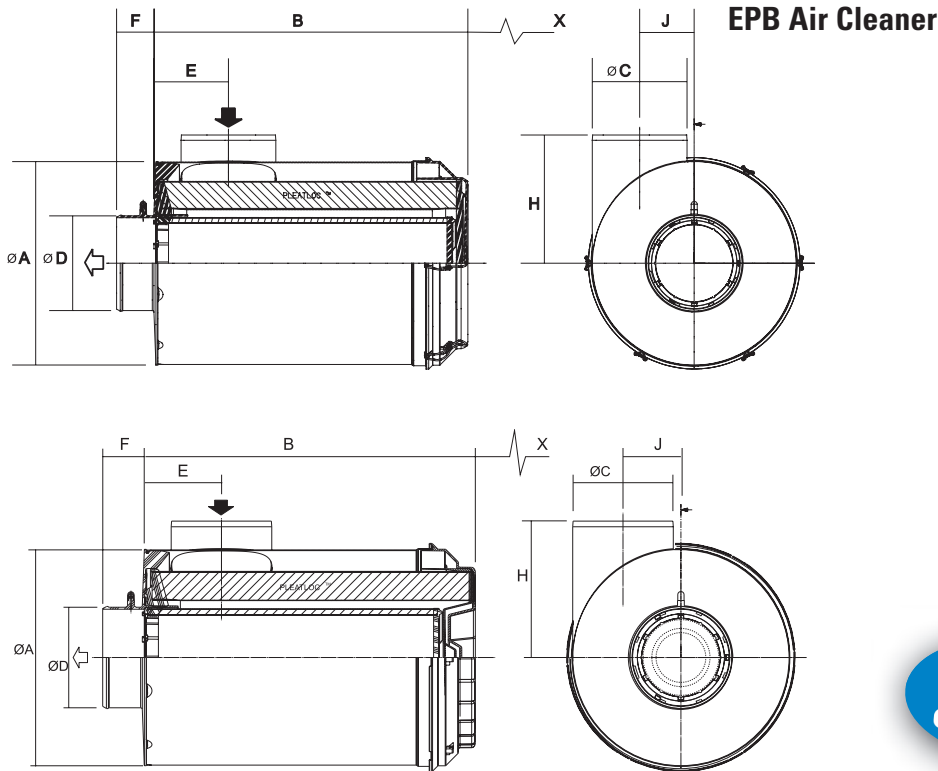

EPB Air Cleaner

ERB2 Air Cleaner

TopSpin™ Pre-Cleaner

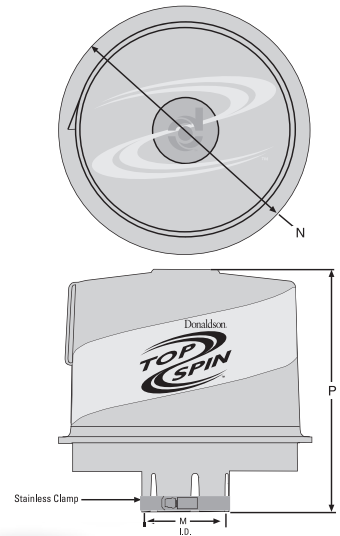

UNIQUE DESIGN CONCEPT

| Style | Air Cleaner Model No. | Airflow Range m ³ /min. | Dimensions (mm) | | | | | | | | | | Pre-Cleaner | M | N | P |
|-------|-----------------------|------------------------------------|-----------------|-----|-----|-----|-----|------|-----|-----|-----|---------|-------------|-----|-----|---|
| | | | A | B | C | D | E | F | H | J | X° | | | | | |
| EPB | B070005 | 2 - 5 | 182 | 334 | 76 | 76 | 45 | 27 | 115 | 145 | 340 | H002437 | 77 | 162 | 146 | |
| EPB | B080067 | 4 - 7 | 210 | 355 | 95 | 89 | 54 | 31,5 | 130 | 146 | 355 | H002426 | 97 | 242 | 238 | |
| ERB2 | B100126 | 7 - 12 | 259 | 430 | 114 | 102 | 143 | 52 | 205 | 0 | 400 | H002427 | 116 | 242 | 238 | |
| ERB2 | B130058 | 15 - 26 | 330 | 530 | 178 | 152 | 180 | 58 | 215 | 0 | 360 | H002439 | 179 | 297 | 345 | |
| ERB2 | B150058 | 18 - 32 | 381 | 590 | 178 | 178 | 136 | 70 | 241 | 102 | 540 | H002439 | 179 | 297 | 345 | |

X ° Free space needed to remove main element

Medium Dust Conditions

When specifying an Air Cleaner...

Determine the Airflow Requirements of your engine, then find the corresponding m³/min. airflow in the charts below. The restriction numbers - shown in mbar - indicate the approximate initial restriction of each model air cleaner at that m³/min. If there are two air cleaner models that fit your parameters, choosing the one with the lowest restriction will provide the longest service life. When calculating total initial restriction of the entire air intake system, include the restriction caused by ducting, elbows, pre-cleaners, etc.

Restriction Curves

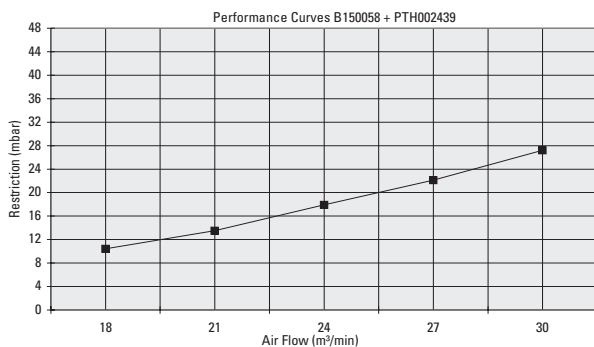
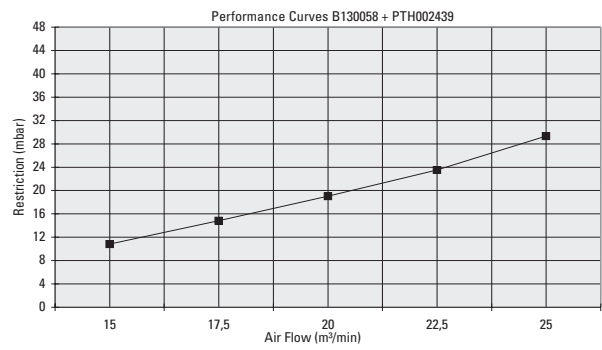
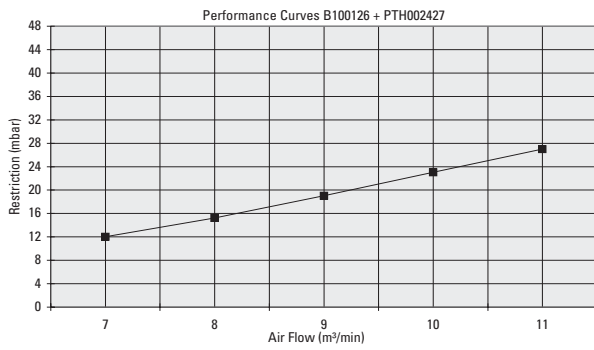
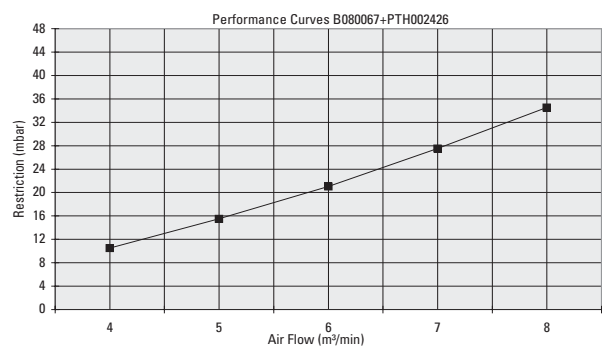
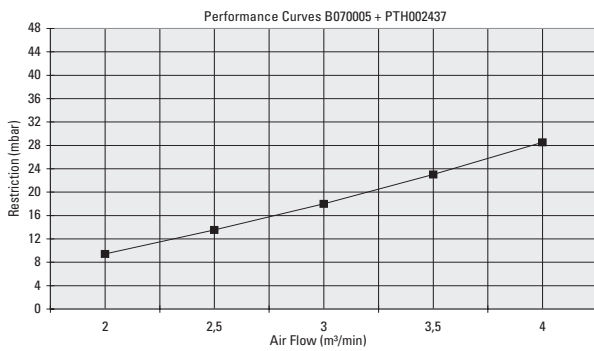

—■— Restr. A/c Piezo

All performance curves are according ISO 5011 standards - Restriction measured at Piezo
 All tests are done with ISO Coarse at Dust Concentration of 1g/m³

Advanced Sealing Technology in Compact Two-Stage Design For the Most Reliable Engine Protection

The FPG Air Cleaner series are two-stage full-plastic air cleaners with a built-in Pre-Cleaner and RadialSeal™ Sealing Technology. They are used on medium-duty applications line generator sets, agricultural tractors, bulldozers, drilling equipment, marine engines, trucks, loaders, backhoe, lifttruck, construction and industrial equipment. The FPG series offers improved reliability and durability with reduced weight and costs.

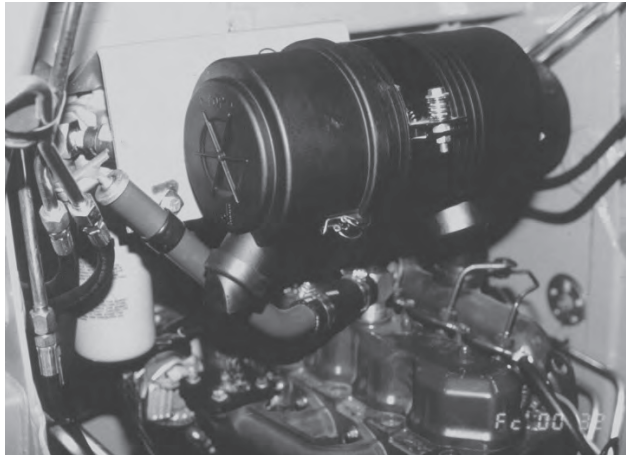

Despite its compact size, the FPG Air Cleaner offers complete engine air protection – removing 99.99+% of the dust and dirt particulate that enters the engine airstream.

Ever since Donaldson developed the first air cleaner in 1915, we have worked closely with original equipment manufacturers to provide filtration solutions to meet changing design and specification requirements for diesel engines.

Because they are made of injection molded high-strength plastic, FPG air cleaners offer the flexibility to overcome space limitations for underhood air cleaners. Donaldson employs innovative plastic materials and production techniques that result in air cleaners that are corrosion-free and lighter in weight than traditional metal air cleaners - yet without sacrificing sturdiness. Our extensive vibration testing reveals this to be a more durable design than most metal air cleaners.



The filter inside the air cleaner is also quite different from the traditional design: one-piece molded urethane endcaps encase the ends of the media and filter liners, eliminating the metal caps and plastisol potting compound that were traditionally used. The glued-on gasket found on conventional filters is gone – now, the inside surface of the open end is actually the radial sealing surface.

Small, Durable and Corrosion-Free The World's Easiest to Service Air Cleaner

Applications

- Provides up to 16 m³/min airflow per air cleaner - double throughput by using two units
- Installation can be horizontal, vertical, or even at an angle (as long as Vacuator™ Valve points down)
- 4", 5", 7", & 10" diameter sizes
- Temperature tolerance: to 83°C sustained

(Do not install next to turbocharger, muffler, exhaust pipes, or other high-temp component.)

Air Cleaner Features

- Easy to service! No tools needed! Usually done in 5 minutes or less!
- Durable plastic housing - corrosion-free and lightweight
- Two-stage air filtration! Built-in, tangential pre-cleaner ahead of primary filter removes up to 85% of incoming dust
- Choose 90° or straight outlet to fit your application
- Easy to fasten latches (no bolts!) retain dust cup/cover
- 45° Vacuator™ Valve orientation permits either vertical or horizontal air cleaner mounting (the dust cup can be incrementally rotated to suit specific application)
- Safety filter protects engine during in-field filter changeouts
- Already tapped to accept filter service indicator (see the Accessories section for indicator options)
- Indicator thread size = 1/8-27NPT (MALE)



Filter Features

- Exclusive Radial Seal Sealing Technology means reliability and easy service - the filter is self-centering and self-aligning!
- One piece, molded urethane endcaps encase the filter media and liners - reducing components, adding reliability and lowering cost



Some models are available with the twist and lock cover design and called FPG Alexin™. See page 70-77.

FPG Specifications

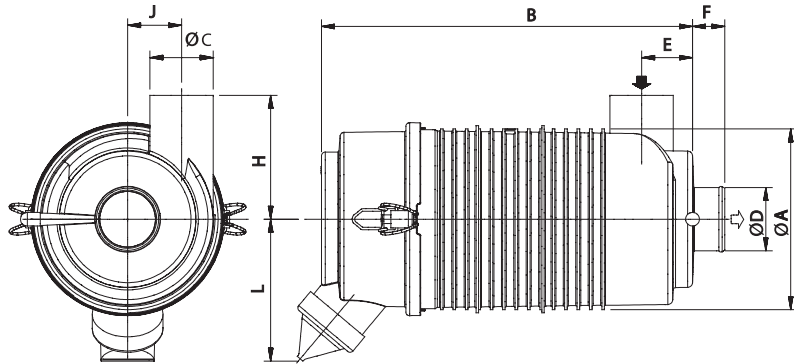

FPG05

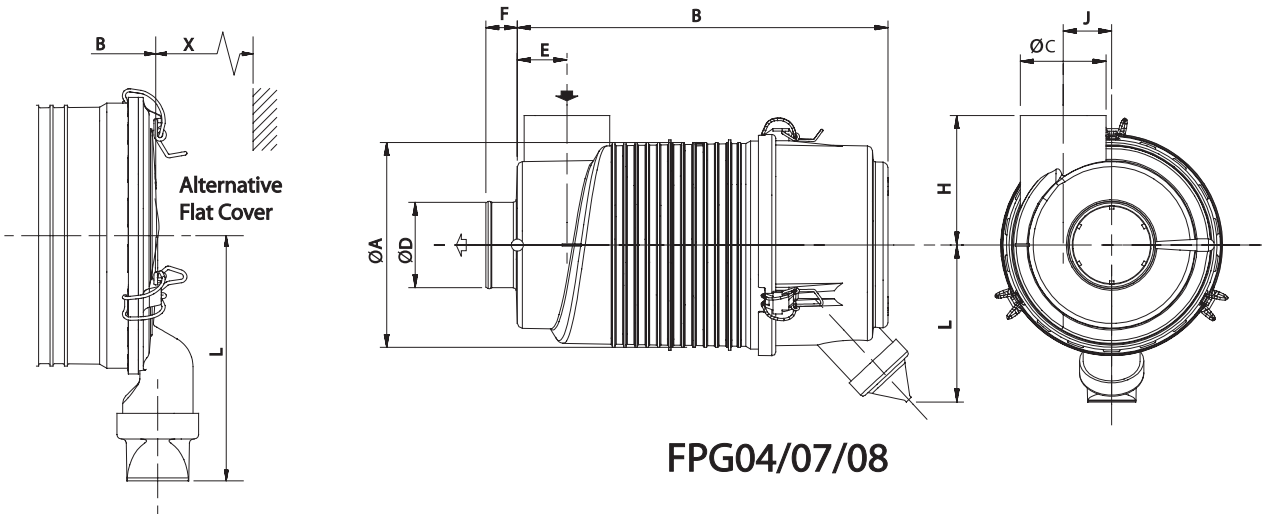

FPG04/07/08

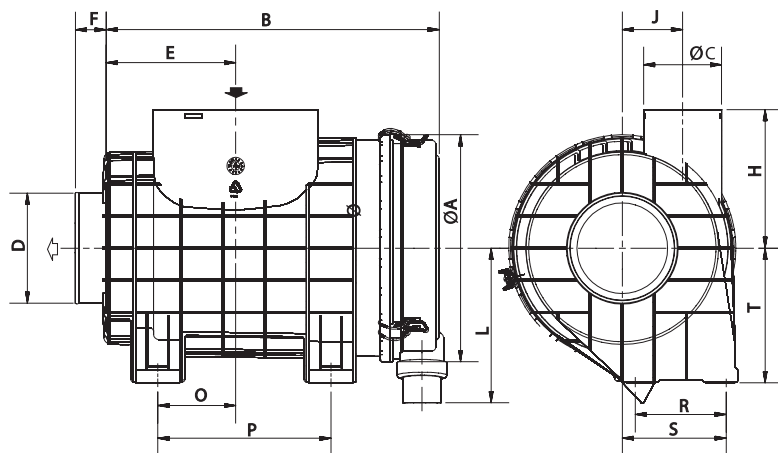

FPG10

FPG Specifications - Service Parts

| Air Cleaner Model No. | Airflow Range m ³ /min. | Dimensions (mm) | | | | | | | | | | | | | | |
|-----------------------|------------------------------------|-----------------|-----|-----|-----|-----|----|-----|------|-----|----|-----|-----|-----|-----|-----|
| | | A | B | C | D | E | F | H | J | L | O | P | R | S | T | X° |
| G042546 • | 0,5 - 1 | 122 | 189 | 45 | 45 | 40 | 25 | 83 | 37 | 105 | - | - | - | - | - | 137 |
| G042575 * • | 0,5 - 1 | 122 | 189 | 45 | 45 | 40 | 25 | 83 | 37 | 105 | - | - | - | - | - | 137 |
| G057502 * | 1 - 3 | 146 | 300 | 51 | 51 | 42 | 25 | 100 | 43,5 | 115 | - | - | - | - | - | 300 |
| G057504 | 1 - 3 | 146 | 300 | 51 | 51 | 42 | 25 | 100 | 43,5 | 115 | - | - | - | - | - | 300 |
| G057505 • | 1 - 3 | 146 | 300 | 51 | 51 | 42 | 25 | 100 | 43,5 | 115 | - | - | - | - | - | 300 |
| G070006 * | 2 - 5 | 182 | 330 | 76 | 76 | 45 | 27 | 115 | 43 | 138 | - | - | - | - | - | 330 |
| G070059 * " | 2 - 5 | 182 | 334 | 76 | 76 | 45 | 27 | 115 | 43 | 171 | - | - | - | - | - | 340 |
| G070009 | 2 - 5 | 182 | 330 | 76 | 76 | 45 | 27 | 115 | 43 | 138 | - | - | - | - | - | 330 |
| G070060 " | 2 - 5 | 182 | 334 | 76 | 76 | 45 | 27 | 115 | 43 | 171 | - | - | - | - | - | 340 |
| G082503 * | 4 - 8 | 212 | 355 | 95 | 89 | 54 | 30 | 130 | 48 | 215 | - | - | - | - | - | 355 |
| G082508 * | 4 - 8 | 212 | 355 | 95 | 89 | 54 | 30 | 130 | 48 | 215 | - | - | - | - | - | 355 |
| G082505 | 4 - 8,5 | 212 | 355 | 95 | 89 | 54 | 30 | 130 | 48 | 215 | - | - | - | - | - | 355 |
| G100274 | 6 - 12 | 262 | 385 | 190 | 127 | 150 | 35 | 180 | 69 | 180 | 90 | 200 | 105 | 120 | 156 | - |
| G100275 | 8 - 16 | 262 | 530 | 190 | 127 | 150 | 35 | 180 | 69 | 180 | 90 | 200 | 105 | 120 | 156 | - |
| G100280* | 6 - 11 | 262 | 385 | 190 | 127 | 150 | 35 | 180 | 69 | 180 | 90 | 200 | 105 | 120 | 156 | - |

* Includes safety element • High pulsation application
 *° Free space needed to remove the main element " Flat cover

Service Parts

| Air Cleaner Model No. | Main Element | Safety Element | Access Cover Assy | Vacuator™ valve | Raincap | Plastic Mounting Band** |
|-----------------------|--------------|----------------|-------------------|-----------------|---------|-------------------------|
| G042546 | P822686 | - | P777153 | P522958 | H770066 | P777151 |
| G042575 | P822686 | P535396 | P777153 | P522958 | H770066 | P777151 |
| G057502 | P772578 | P775298 | P775308 | P522958 | H001377 | P777730 |
| G057504 | P772578 | - | P775308 | P522958 | H001377 | P777730 |
| G057505 | P775631 | - | P775308 | P522958 | H001377 | P777730 |
| G070006 | P772579 | P775300 | P775311 | P522958 | H001379 | P777731 |
| G070009 | P772579 | - | P775311 | P522958 | H001379 | P777731 |
| G070059 | P772579 | P775300 | P778758 | P522958 | H001379 | P777731 |
| G070060 | P772579 | - | P778758 | P522958 | H001379 | P777731 |
| G082503 | P772580 | P775302 | P775305 | P775569 | H770010 | P777732 |
| G082505 | P772580 | - | P775305 | P775569 | H770010 | P777732 |
| G082508 | P772580 | P775302 | P775305 | P522958 | H770010 | P777732 |
| G100274 | P777588 | - | P777589 | P158914 | P776343 | Integrated |
| G100275 | P777592 | - | P777593 | P158914 | P776343 | Integrated |
| G100280 | P777588 | P777779 | P777589 | P158914 | P776343 | Integrated |

* Spare Part only ** Only one mounting band needed per air cleaner

When specifying an Air Cleaner...

Determine the Airflow Requirements of your engine, then find the corresponding $m^3/min.$ airflow in the charts below. The restriction numbers - shown in mbar at the left side of the chart - indicate the approximate initial restriction of each model air cleaner at that $m^3/min.$ When calculating total initial restriction of the entire air intake system, include the restriction caused by ducting, elbows, pre-cleaners, etc. The estimated lab life hours are indicated at the right side of the chart.

FPG Performance Curves

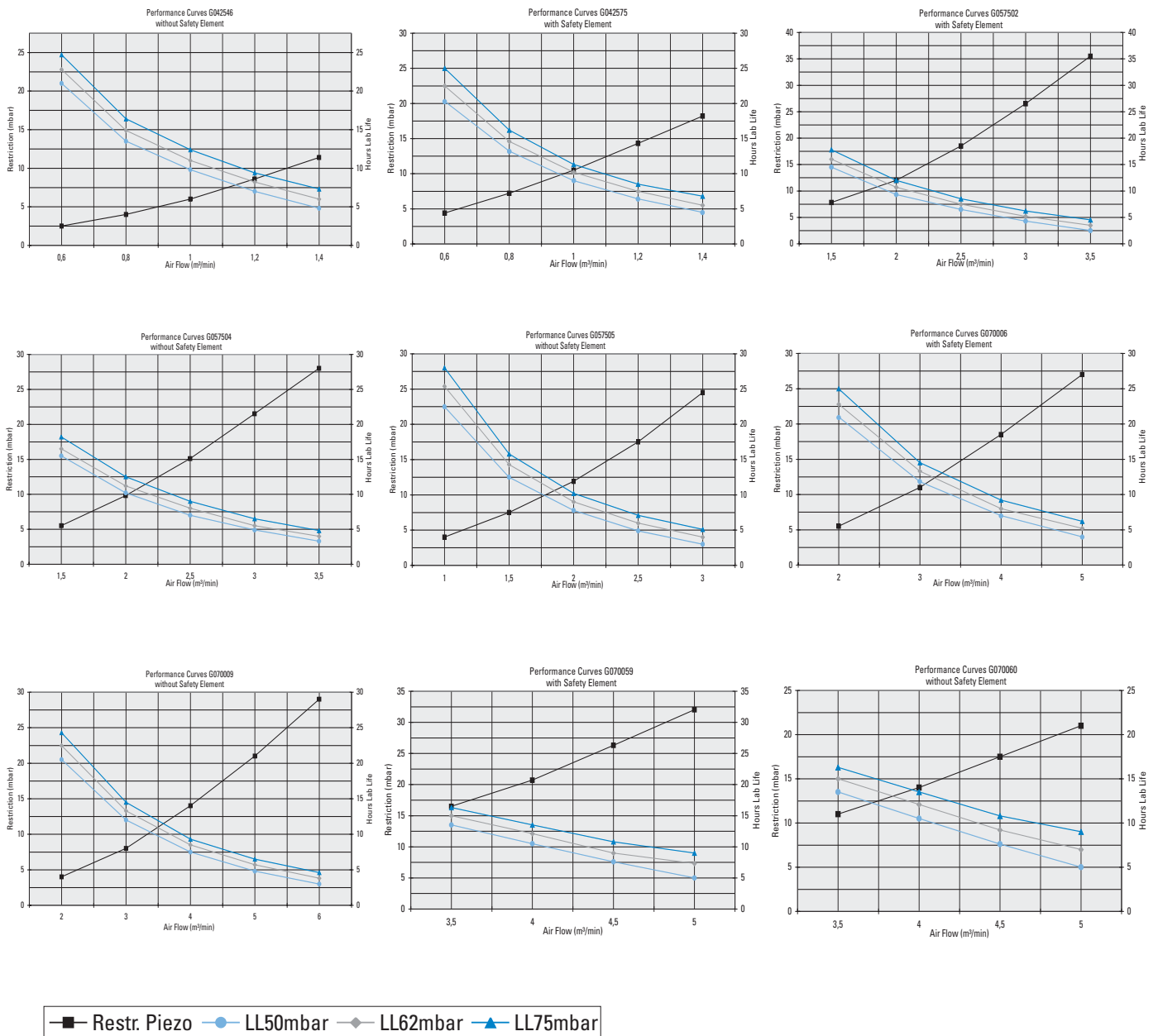

All performance curves are according ISO 5011 standards - Restriction measured at Piezo
 All tests are done with ISO Coarse at Dust Concentration of $1g/m^3$

FPG Performance Curves

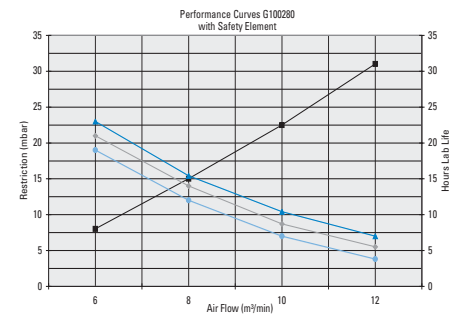
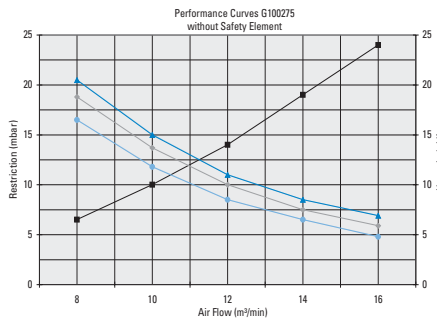
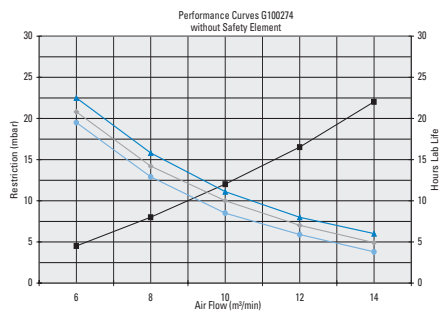
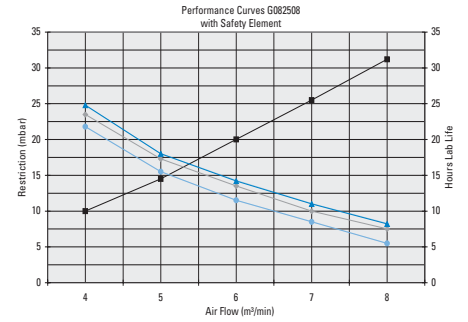
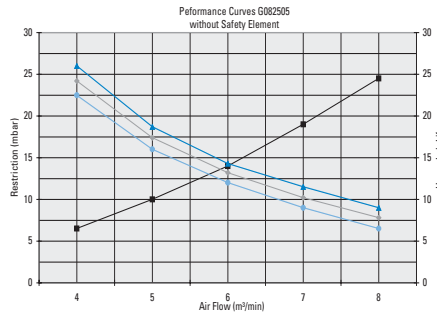
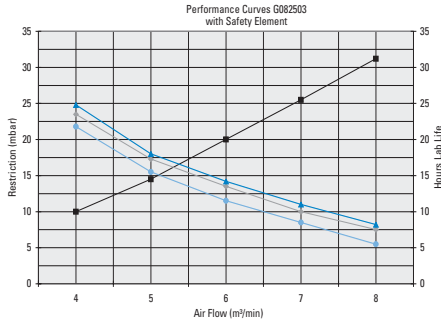

Page 1



All performance curves are according ISO 5011 standards - Restriction measured at Piezo
All tests are done with ISO Coarse at Dust Concentration of 1g/m³

Advanced Sealing Technology in Compact Two-Stage Design For the Most Reliable Engine Protection

The FPG Alexin™ Air Cleaner series are two-stage full-plastic air cleaners with a built-in Pre-Cleaner and RadialSeal™ Sealing Technology.

They are used on medium-duty applications line generator sets, agricultural tractors, bulldozers, drilling equipment, marine engines, trucks, loaders, backhoe, lifttruck, construction and industrial equipment. The FPG series offers improved reliability and durability with reduced weight and costs.

Ever since the introduction of the Donaldson RadialSeal™ product line in 1989 with the launch of the FPG Air Cleaner, Donaldson has developed many versions of this products and has continued to invest time and money in the further development of this RadialSeal filter concept, with the Alexin™ product line as one of the result.

The Donaldson Alexin brandname identifies Donaldson products using the proven, reliable Donaldson RadialSeal Technology for the filter elements combined with the ease of use of a Twist and Lock cover, that provides a convenient cover locking system with a design that saves space.



Despite its compact size, the FPG Air Cleaner offers complete engine air protection – removing 99.99+% of the dust and dirt particulate that enters the engine airstream.

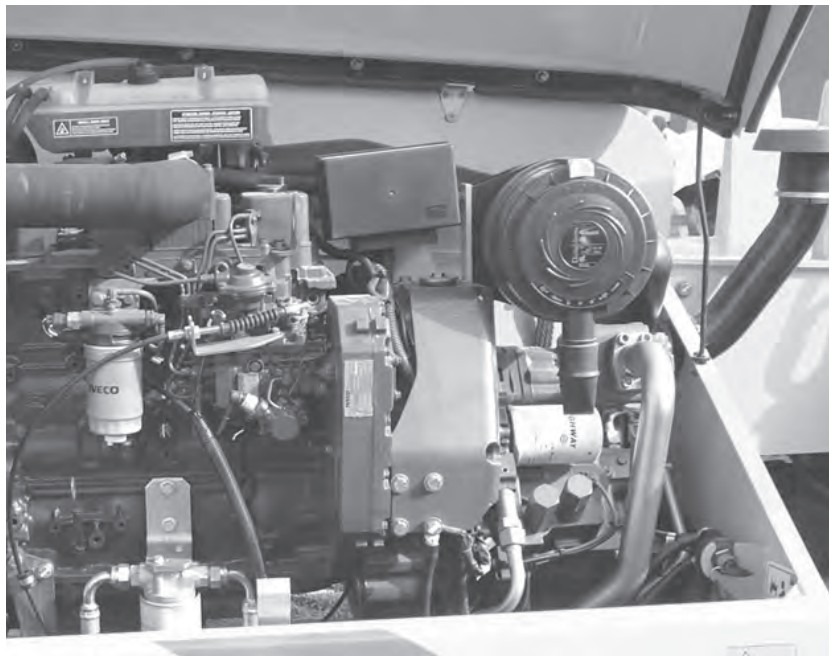

Small, Durable and Corrosion-Free The World's Easiest to Service Air Cleaner

Applications

- Provides up to 14 m³/min airflow per air cleaner - double throughput by using two units
- Installation can be horizontal, vertical, or even at an angle (as long as Vacuator™ Valve points down)
- 6", 8", 9", & 10" diameter sizes
- Temperature tolerance: to 83°C sustained

(Do not install next to turbocharger, muffler, exhaust pipes, or other high-temp component.)

Air Cleaner Features

- Easy to service! No tools needed! Usually done in 5 minutes or less!
- Durable plastic housing - corrosion-free and lightweight
- Two-stage air filtration! Built-in, tangential pre-cleaner ahead of primary filter removes up to 85% of incoming dust
- Choose 90° or straight outlet to fit your application
- Easy to fasten latches (no bolts!) retain dust cup/cover
- 45° Vacuator™ Valve orientation permits either vertical or horizontal air cleaner mounting (the dust cup can be incrementally rotated to suit specific application)
- Safety filter protects engine during in-field filter changeouts
- Already tapped to accept filter service indicator (see the Accessories section for indicator options)
- Indicator thread size = 1/8-27NPT (MALE)



Dust removed in the first stage of cleaning is discharged automatically through the Vacuator™ Valve

Filter Features

- Exclusive Radial Seal Sealing Technology means reliability and easy service - the filter is self-centering and self-aligning!
- One piece, molded urethane endcaps encase the filter media and liners - reducing components, adding reliability and lowering cost
- Cover is unlocked with a yellow "finger", twisted to the left and removed from the filter housing. It's that simple! To fit the cover housing, just reverse the sequence. Only one mounting band is needed per body size.

FPG Alexin™ Specifications

90° elbow outlet

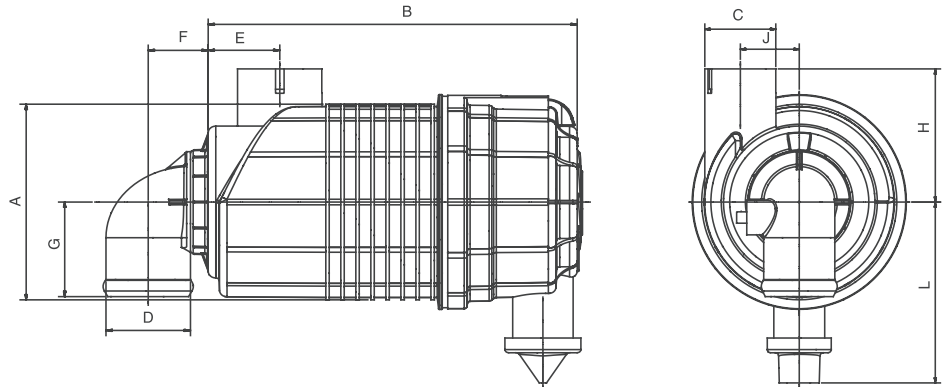

Straight outlet

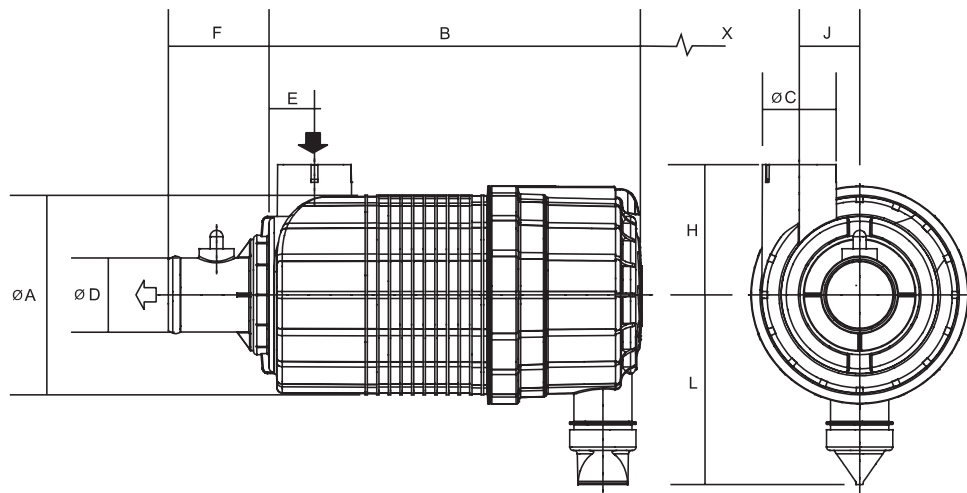

| Air Cleaner Model No. | Airflow Range m ³ /min. | Dimensions (mm) | | | | | | | | | | |
|-------------------------|------------------------------------|-----------------|-----|------|-------|------|------|-----|-----|----|-----|-----|
| | | A | B | C | D | E | F | G | H | J | L | X° |
| G065497 ^{**} * | 1,5 - 4 | 172 | 326 | 63,5 | 63,5 | 43,5 | 40,8 | 78 | 112 | 52 | 163 | 300 |
| G065498 " | 1,5 - 4 | 172 | 326 | 63,5 | 63,5 | 43,5 | 40,8 | 78 | 112 | 52 | 163 | 300 |
| G065499 •* | 1,5 - 4 | 172 | 326 | 63,5 | 63,5 | 43,5 | 82,2 | - | 112 | 52 | 163 | 300 |
| G065500 • | 1,5 - 4 | 172 | 326 | 63,5 | 63,5 | 43,5 | 82,2 | - | 112 | 52 | 163 | 300 |
| G082580 ^{**} * | 4 - 7,5 | 213 | 369 | 95 | 89 | 53,4 | 53,5 | 105 | 138 | 57 | 183 | 355 |
| G082581 " | 4 - 8 | 213 | 369 | 95 | 89 | 53,4 | 53,5 | 105 | 138 | 57 | 183 | 355 |
| G082582 •* | 4 - 7,5 | 213 | 369 | 95 | 89 | 53,4 | 83 | - | 138 | 57 | 183 | 355 |
| G082583 • | 4 - 8 | 213 | 369 | 95 | 89 | 53,4 | 83 | - | 138 | 57 | 183 | 355 |
| G090219 ^{**} * | 5 - 10 | 242 | 409 | 114 | 89 | 61,5 | 53,5 | 105 | 170 | 60 | 260 | 370 |
| G090220 " | 5 - 10 | 242 | 409 | 114 | 89 | 61,5 | 53,5 | 105 | 170 | 60 | 260 | 370 |
| G090225 •* | 5 - 10 | 242 | 409 | 114 | 101,5 | 61,5 | 87 | - | 170 | 60 | 260 | 370 |
| G090226 • | 5 - 10 | 242 | 409 | 114 | 101,5 | 61,5 | 87 | - | 170 | 60 | 260 | 370 |
| G100317 ^{**} * | 8 - 11 | 268 | 432 | 114 | 101,5 | 70,5 | 60,2 | 120 | 185 | 72 | 269 | 390 |
| G100318 " | 8 - 12 | 268 | 432 | 114 | 101,5 | 70,5 | 60,2 | 120 | 185 | 72 | 269 | 390 |
| G100319 •* | 8 - 11 | 268 | 432 | 114 | 101,5 | 70,5 | 87,5 | - | 185 | 72 | 269 | 390 |
| G100320 • | 8 - 12 | 268 | 432 | 114 | 101,5 | 70,5 | 87,5 | - | 185 | 72 | 269 | 390 |

^{**} 90° elbow outlet
 • Straight outlet
 * Includes safety element
 X° Free space needed to remove main element

FPG Alexin™ Service Parts

| Service Parts | | | | | | |
|-----------------------|--------------|----------------|-------------------|-----------------|---------|-------------------------|
| Air Cleaner Model No. | Main Element | Safety Element | Access Cover Assy | Vacuator™ valve | Raincap | Plastic Mounting Band** |
| G065497 | P822768 | P822769 | P780401 | P522958 | H001378 | P778810 |
| G065498 | P822768 | - | P780401 | P522958 | H001378 | P778810 |
| G065499 | P822768 | P822769 | P780401 | P522958 | H001378 | P778810 |
| G065500 | P822768 | - | P780401 | P522958 | H001378 | P778810 |
| G082580 | P828889 | P829333 | P780403 | P158914 | H770010 | P777732 |
| G082581 | P828889 | - | P780403 | P158914 | H770010 | P777732 |
| G082582 | P828889 | P829333 | P780403 | P158914 | H770010 | P777732 |
| G082583 | P828889 | - | P780403 | P158914 | H770010 | P777732 |
| G090219 | P780522 | P780523 | P780524 | P776008 | H770012 | P780532 |
| G090220 | P780522 | - | P780524 | P776008 | H770012 | P780532 |
| G090225 | P780522 | P780523 | P780524 | P776008 | H770012 | P780532 |
| G090226 | P780522 | - | P780524 | P776008 | H770012 | P780532 |
| G100317 | P781039 | P777639 | P780578 | P776008 | H770012 | P780594 |
| G100318 | P781039 | - | P780578 | P776008 | H770012 | P780594 |
| G100319 | P781039 | P777639 | P780578 | P776008 | H770012 | P780594 |
| G100320 | P781039 | - | P780578 | P776008 | H770012 | P780594 |

** Only one mounting band needed per air cleaner * Spare Part only

When specifying an Air Cleaner...

Determine the Airflow Requirements of your engine, then find the corresponding m³/min. airflow in the charts below. The restriction numbers - shown in mbar at the left side of the chart - indicate the approximate initial restriction of each model air cleaner at that m³/min. When calculating total initial restriction of the entire air intake system, include the restriction caused by ducting, elbows, pre-cleaners, etc. The estimated lab life hours are indicated at the right side of the chart.

FPG Alexin™ Performance Curves

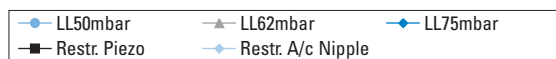
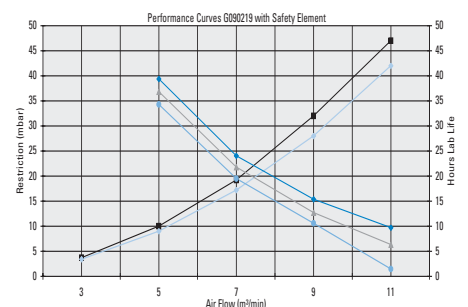
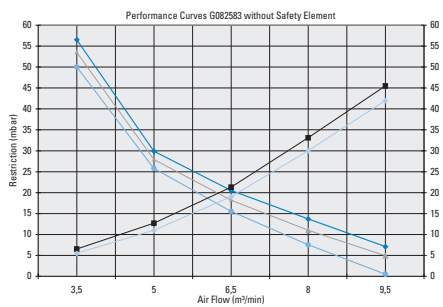
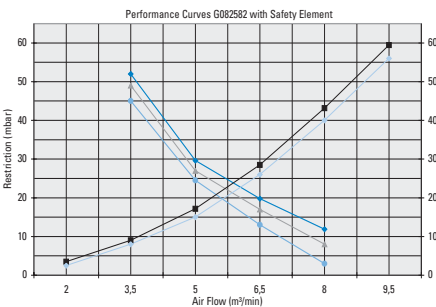
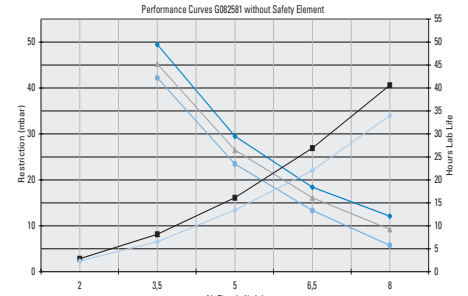
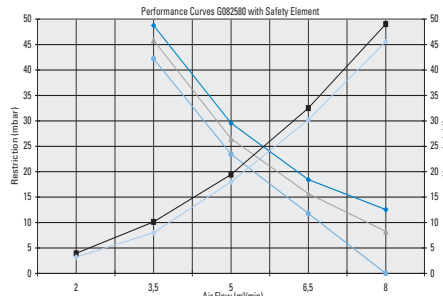
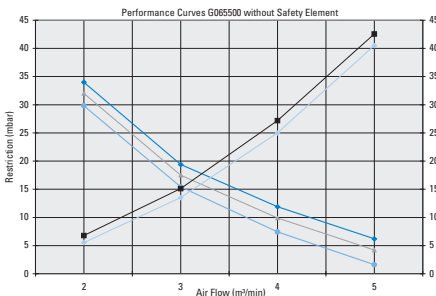
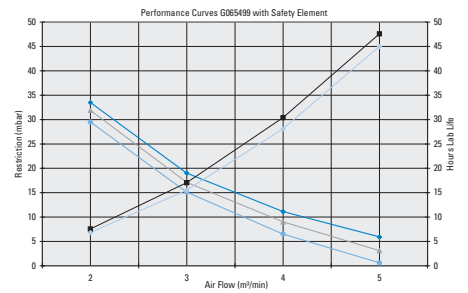
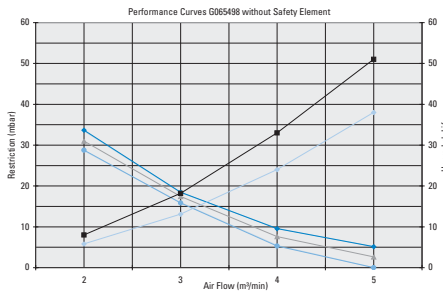
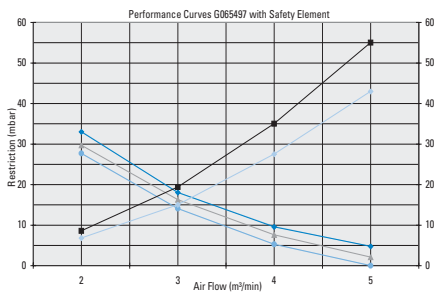

All performance curves are according ISO 5011 standards - Restriction measured at Piezo
All tests are done with ISO Coarse at Dust Concentration of 1g/m³

FPG Alexin™ Performance Curves

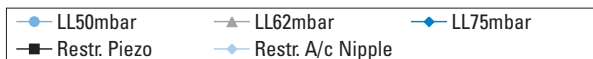
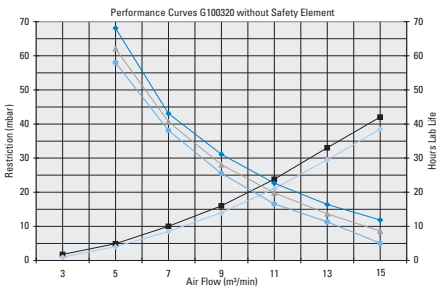
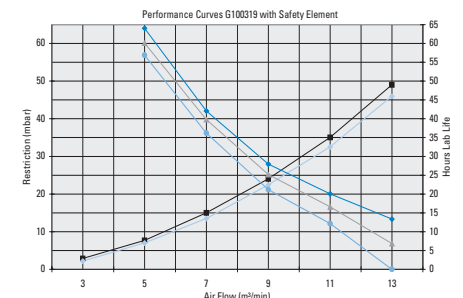
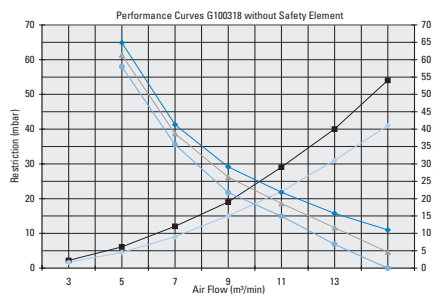
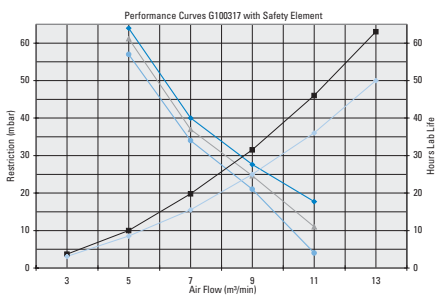
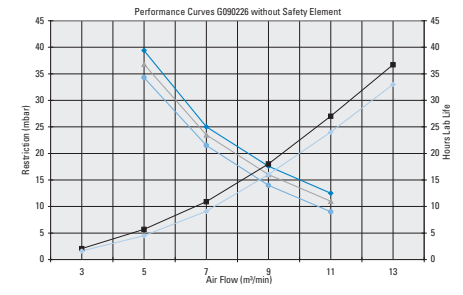
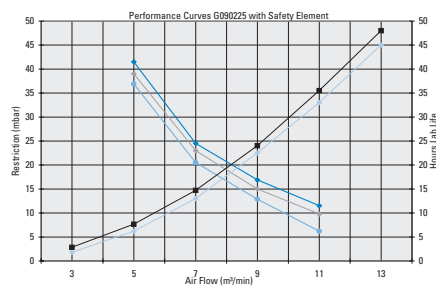
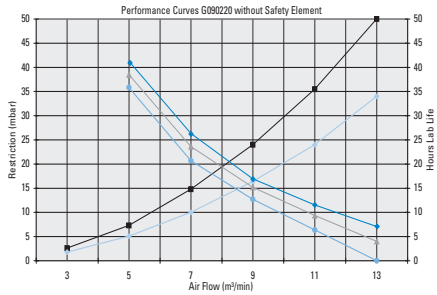

All performance curves are according ISO 5011 standards - Restriction measured at Piezo
 All tests are done with ISO Coarse at Dust Concentration of 1g/m³

1 Remove the Filter

Unfasten or unlatch the service cover for the FPG models. For the FPG Alexin models, the cover is unlocked with a yellow "finger", twisted to the left and removed from the filter housing. Because the filter fits tightly over the outlet tube to create the critical seal, there will be some initial resistance, similar to breaking the seal on a jar. Gently move the end of the filter back and forth to break the seal then rotate while pulling straight out. Avoid knocking the filter against the housing.



Rotate the filter while pulling straight out.

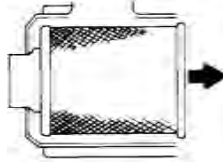

If your air cleaner has a safety filter, replace it every third primary filter change. Remove the safety filter as you would the primary filter. Make sure you cover the air cleaner outlet tube to avoid any unfiltered contaminant dropping into the engine.

2 Clean Both Surfaces of the Outlet Tube and Check the Vacuator™ Valve

Use a clean cloth to wipe the filter sealing surface and the inside of the outlet tube. Contaminant on the sealing surface could hinder an effective seal and cause leakage. Make sure that all contaminant is removed before the new filter is inserted. Dirt accidentally transferred to the inside of the outlet tube will reach the engine and cause wear. Engine manufacturers say that it takes only a few grams of dirt to "dust" an engine! Be careful not to damage the sealing area on the tube.



Outer edge of the outlet tube

Wipe both sides of the outlet tube clean.



Inner edge of the outlet tube

If your air cleaner is equipped with a Vacuator Valve Visually check and physically squeeze to make sure the valve is flexible and not inverted, damaged or plugged.



3 Inspect the Old Filter for Leak Clues

Visually inspect the old filter for any signs of leaks. A streak of dust on the clean side of the filter is a telltale sign. Remove any cause of leaks before installing new filter.

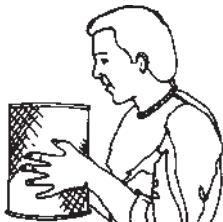

4 Inspect the New Filter for Damage

Inspect the new filter carefully, paying attention to the inside of the open end, which is the sealing area. NEVER install a damaged filter. A new Donaldson radial seal filter may have a dry lubricant on the seal to aid installation.



5 Insert the New Radial Seal Filter Properly

If you're servicing the safety filter, this should be seated into position before installing the primary filter.

Insert the new filter carefully. Seat the filter by hand, making certain it is completely into the air cleaner housing before securing the cover in place.



The critical sealing area will stretch slightly, adjust itself and distribute the sealing pressure evenly. To complete a tight seal, apply pressure by hand at the outer rim of the filter, not the flexible center. Avoid pushing on the center of the urethane end cap. No cover pressure is required to hold the seal. NEVER use the service cover to push the filter into place! Using the cover to push the filter in could cause damage to the housing, cover fasteners and will void the warranty.

If the service cover hits the filter before it is fully in place, remove the cover and push the filter (by hand) further into the air cleaner and try again. The cover should go on with no extra force.

Once the filter is in place, secure the service cover for the FPG models. For the FPG Alexin models, the cover is locked with a yellow "finger", twisted to the right.



Caution

NEVER use the service cover to push the filter into place! Using the cover to push the filter in could cause damage to the housing, cover fasteners and will void the warranty.



6 Check Connectors for Tight Fit

Make sure that all mounting bands, clamps, bolts, and connections in the entire air cleaner system are tight. Check for holes in piping and repair if needed. Any leaks in your intake piping will send dust directly to the engine!

Designed Exclusively for the FPG + FPG Alexin™ Air Cleaners

- Band has tabs on the inside circumference which fit exactly into notches on the FPG housing to hold the housing in position.
- Tight fit between body and mounting band enhances components durability.
- The springs compensate for dimensional changes due to temperature fluctuations, maintaining a tight fit.
- Critical functions, i.e. Twist and Lock mechanism, remain unaffected.
- Fool proof installation: bolts are tightened to predetermined height.
The band is under tension at all times. More user friendly as the base is no longer split.
- Donaldson polymer bands are completely non corrosive, lightweight, easy to install and economical.

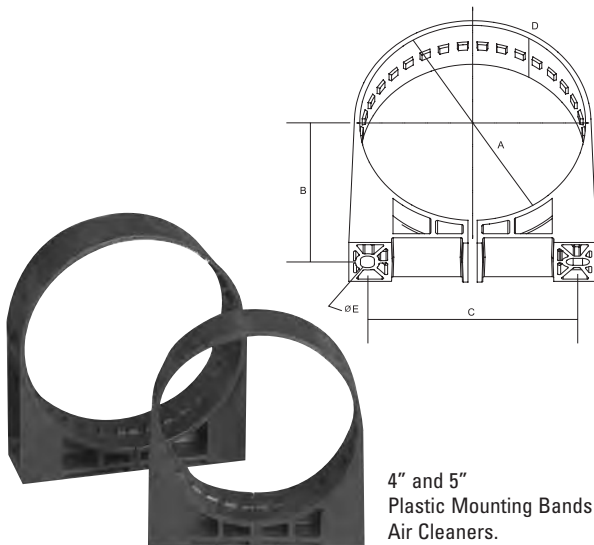

4" and 5"
Plastic Mounting Bands for FPG
Air Cleaners.

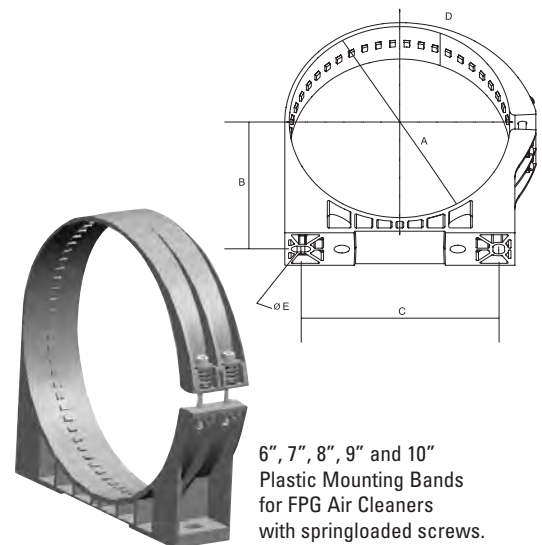

6", 7", 8", 9" and 10"
Plastic Mounting Bands
for FPG Air Cleaners
with springloaded screws.

| Part Number | Diameter | Dimensions (mm) | | | | |
|---|-----------------------------------|-----------------|-------|-------|------|----|
| | | A | B | C | D | E |
| 4" and 5" Mounting Bands for FPG Air Cleaners | | | | | | |
| P777151 | 4" | 122 | 79 | 116 | 40 | 9 |
| P777730 | 5" | 146 | 90 | 136 | 50,5 | 9 |
| 6", 7", 8", 9" and 10" Mounting Bands for FPG Air Cleaners with Springloaded Screws | | | | | | |
| P778810 | 6" | 171,5 | 99,5 | 153,5 | 50,5 | 9 |
| P778901* | 6" | 171,5 | 99,5 | 90 | 50,5 | 9 |
| P781831* | 6" | 171,5 | 99,5 | 93 | 50,5 | 9 |
| P777731 | 7" | 182 | 104,5 | 163 | 50,5 | 9 |
| P777732 | 8" | 211,5 | 119,5 | 190 | 50,5 | 9 |
| P780580* | 8" | 211,5 | 119,5 | 110 | 50,5 | 9 |
| P780378** | 8" | 212 | 119,5 | 110 | 85 | 9 |
| P780532 | 9" | 241 | 136 | 143 | 50,5 | 9 |
| P780594 | 10" | 268 | 149,5 | 143 | 80 | 11 |
| * With insert M8 | ** Double 8" Mounting Band needed | | | | | |

Mounted Underhood Two-Stage Filtration for Large Construction & Mining Machines

The FTG Cycloflow™ Air Cleaner is a two-stage air cleaner with built-in Pre-Cleaner and Axial Seal Sealing Technology. The air cleaner is mounted underhood with the service cover on the outside and an optional inlet hood on top.

Applications

- Allows 32-59 m³/min. airflow throughput per air cleaner
- Horizontal installation
- Designed for large industrial and construction machines: crawler tractors, crane loaders, excavators and air compressors with large engines operating in severe dust environments
- Sustained temperature tolerance: to 82°C

Air Cleaner Features

- Unique, flared inlet allows maximum airflow with low restriction
- 21" body diameters
- Two-stage air cleaning deals with very dusty environment:
 - (1) Built-in louver spins air to separate up to 85% of incoming dust before it reaches the filter
 - (2) Primary filter removes up to 99.99% of the remaining dust
- Built-in Vacuator™ Valve collects and releases pre-cleaned dust
- Safety filter on all models protects engine inlet during filter changeout
- Housing is metal and coated with a corrosion and chemical resistant polymer paint
- Indicator thread size = 1/8-27NPT (MALE)

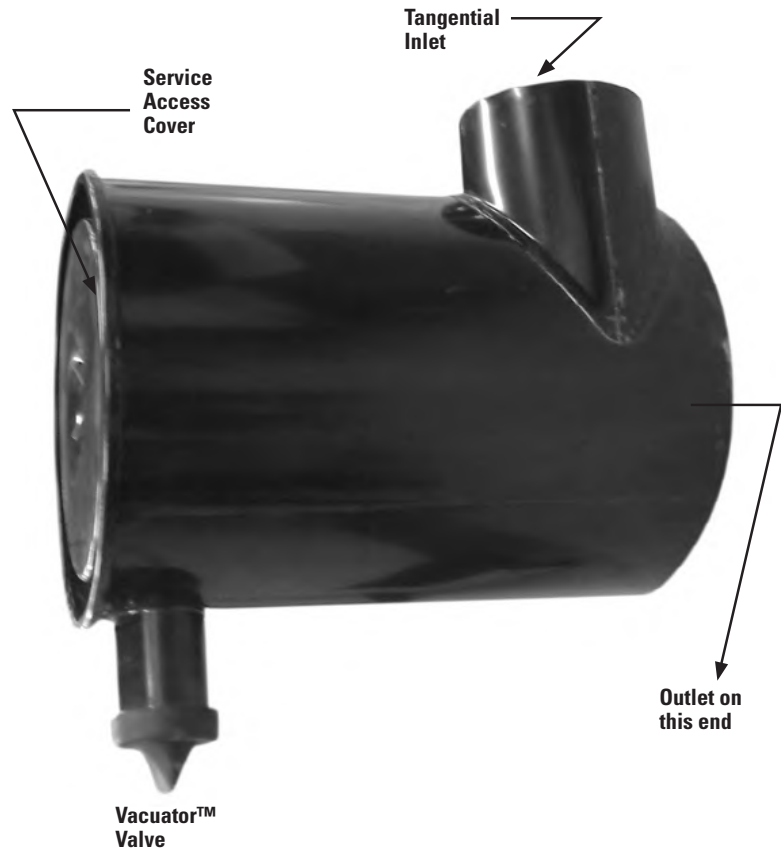

Filter Features

Replacement filter choices include an extended service, high efficiency filter for restriction maintenance, and a standard life filter for scheduled maintenance

Accessories

- Each FTG is tapped to accept a filter service indicator
- Order mounting bands, hoods, and other accessories separately

FTG Cycloflow™ Specifications - Service Parts

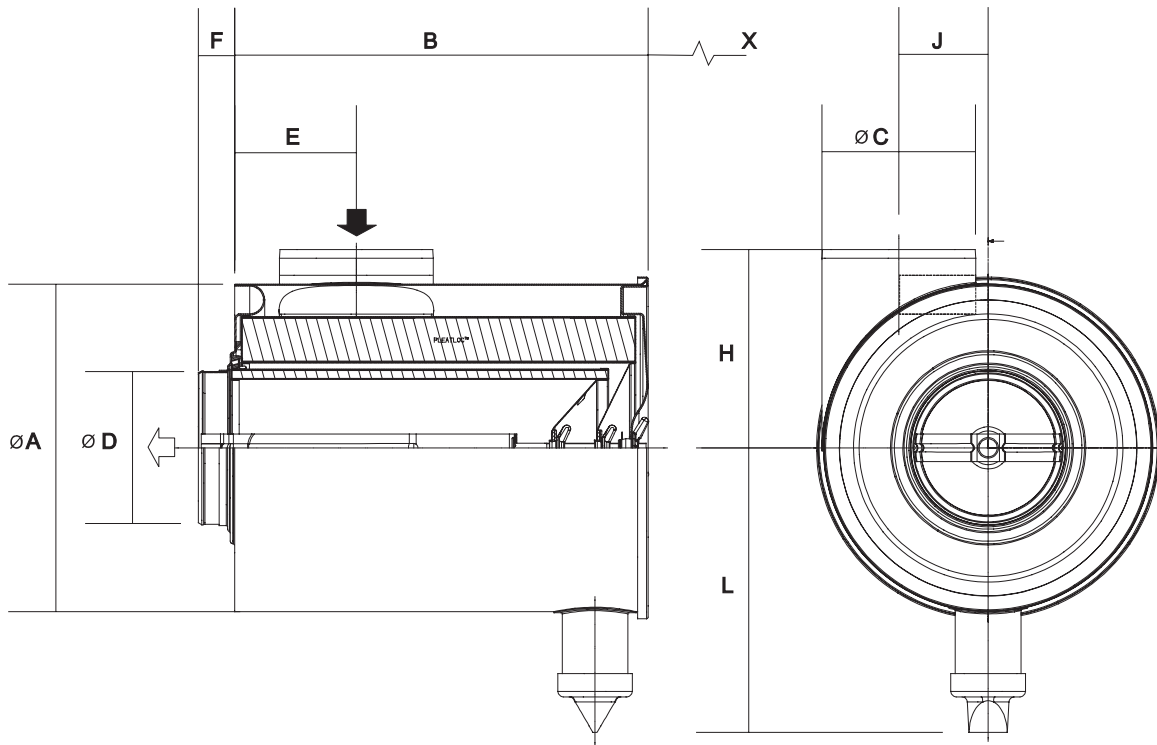

| Air Cleaner Model No. | Airflow Range m ³ /min. | Dimensions (mm) | | | | | | | | | |
|-----------------------|------------------------------------|-----------------|-----|-----|-----|-----|----|-----|-----|-----|-----|
| | | A | B | C | D | E | F | H | J | L | X° |
| G210007** | 32 - 59 | 546 | 613 | 254 | 254 | 150 | 90 | 330 | 146 | 442 | 613 |
| G210010* | 32 - 59 | 546 | 613 | 254 | 254 | 150 | 90 | 330 | 146 | 442 | 613 |

" Inlet on opposite side * Includes safety element
 X° Free space needed to remove main element

| Air Cleaner Model No. | Main Element | Safety Element | Service Parts | | | | | Mounting band* |
|-----------------------|--------------|----------------|-----------------|----------|---------------|---------|---------|----------------|
| | | | Vacuator™ valve | Wing Nut | Gasket Washer | Raincap | | |
| G210007 | P182040 | P117781 | P105220 | P116175 | P105740 | H770082 | H770068 | |
| G210010 | P182040 | P117781 | P105220 | P116175 | P105740 | H770082 | H770068 | |

* Two mounting bands needed per Air Cleaner

Medium Dust Conditions

When specifying an Air Cleaner...

Determine the Airflow Requirements of your engine, then find the corresponding m³/min. airflow in the charts below. The restriction numbers - shown in mbar at the left side of the chart - indicate the approximate initial restriction of each model air cleaner at that m³/min. When calculating total initial restriction of the entire air intake system, include the restriction caused by ducting, elbows, pre-cleaners, etc. The estimated lab life hours are indicated at the right side of the chart.

FTG Cycloflow™ Performance Curves

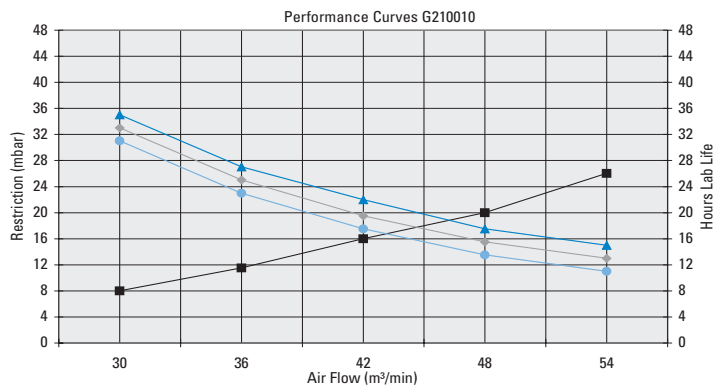
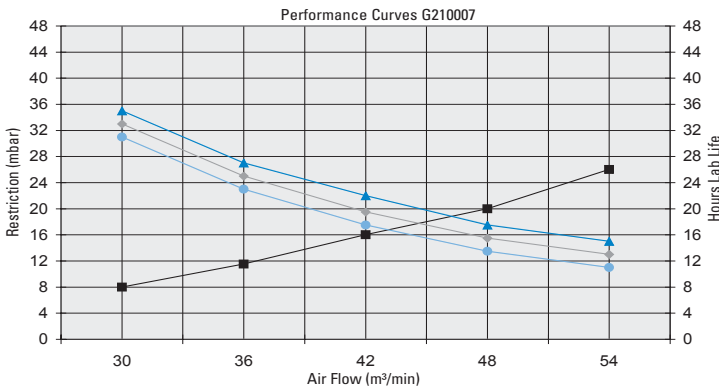

Restr. A/c Piezo
 LL50mbar
 LL62mbar
 LL75mbar

All performance curves are according ISO 5011 standards - Restriction measured at Piezo
 All tests are done with ISO Coarse at Dust Concentration of 1g/m³

1 Remove the old filter gently

“Baby” that dirty filter, until you get it clear of the housing. Accidentally bumping it while still inside means dropped dirt and dust that will contaminate the clean side of your filter housing, before the new filter element has a chance to do its job.

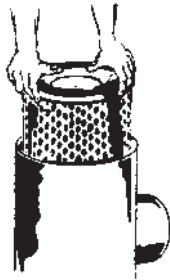

2 Always clean the inside of the housing carefully

Dirt left in the air cleaner housing spells death for your engine. Use a clean, damp cloth to wipe every surface clean. Check it visually to make sure it's clean before putting in a new filter.



3 Always clean the gasket sealing surfaces

An improper gasket seal is one of the most common causes of engine contamination. Make sure that all hardened dirt ridges are completely removed, both on the bottom and top of the air cleaner housing.



4 Check for uneven dirt patterns

Your old filter has valuable clues to dust leakage or gasket sealing problems. A pattern on the filter clean side is a sign that the old filter was not firmly sealed or that a dust leak exists. Identify the cause of that leak and rectify it before installing a new filter.



5 Press your fresh gasket to see that it springs back

Make sure your new filter is made with a highly compressible gasket that springs back (promptly) when finger pressure is released. A high quality gasket is one of the most important parts of the filter.



6 Make sure the gasket seats evenly

If you don't feel the gasket seating evenly for a perfect seal, you don't have protection. Re-check to see if the sealing surface in the housing is clean, and ensure that the filter is the correct model. It may be the wrong size for the housing.



7 Ensure air-tight fit on all connections and ducts

Check that all clamps and flange joints are tight, as well as the air cleaner mounting bolts. Seal any leaks immediately - leaks mean dirt is directly entering your engine.



Superior Protection for Larger Engines RadialSeal Sealing Technology Means Reliable Filtration and Quicker Service

The FRG2 Air Cleaners is a two-stage hybrid air cleaner with RadialSeal™ Sealing Technology. Ideal for medium- to heavy duty applications like construction equipment, agricultural machinery, mining equipment and off-highway vehicles. The FRG2 Air Cleaner is the Next Generation FRG Air Cleaner Product featuring Donaldson's Unique Design Concept.

For more details on this UDC Feature, see page 7.

**Built with
Donaldson
Technology.**



**UNIQUE
DESIGN
CONCEPT**

Applications FRG2

- Horizontal mount required
- Provides variety of airflow volumes to engine: from 6.5 to 51 m³/min.
- Temperature tolerance: to 83°C continuous / 105°C intermittent
- Body diameters of 10", 11", 13", 15" and 18"

Features FRG2

- Two stage filter system: the first stage removes up to 85% of incoming dust
- Vacuator™ Valve automatically releases the pre-cleaned dust
- Proven RadialSeal™ Technology
- Tapped for restriction indicator as standard
- Durable, long-lasting finish. Comprised of two materials: injection molded, high strength polymer service cover and a metal body (the service cover is accessed by latches)
- Indicator thread size = 1/8-27NPT (MALE)

- Mounting the unit directly to the engine is not recommended; excessive engine vibration can cause premature air cleaner structural failure
- Cost effective / Compact and light
- Flexible installation
- Durable, high-tech and easy to service design

Accessories

Donaldson intake accessories for your FRG2 Air Cleaner can help overcome or prevent various problems. For instance:

- Mounting bands for FRG2s must be ordered separately
- If the installed air cleaner will be exposed to rain, snow or debris, an **inlet cap** can prevent moisture ingestion.
- A **service indicator** measures the airflow restriction across the filter, thereby showing how much useful life the filter has left, and when to replace the filter cartridge (see Accessories section of this catalogue).

FRG2 Specifications

**UNIQUE
DESIGN
CONCEPT**



FRG2 FRG Air Cleaners

| | |
|---------|---------|
| G100420 | G100281 |
| G100428 | G100284 |
| G110381 | G110211 |
| G110382 | G110269 |
| G130236 | G130120 |
| G130232 | G130061 |
| G130234 | G130088 |
| G130233 | G130087 |
| G130235 | G130113 |
| G150255 | G150092 |
| G150259 | G150112 |
| G150256 | G150097 |
| G180087 | G180033 |
| G180074 | G180035 |
| G180073 | G180031 |
| G180075 | G180038 |

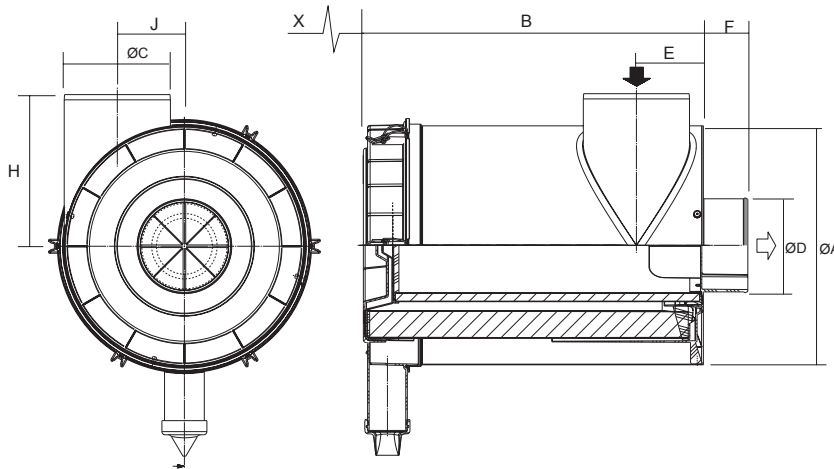

| Air Cleaner Model No. | Airflow Range m ³ /min. | Dimensions (mm) | | | | | | | | | | |
|-----------------------|------------------------------------|-----------------|-----|-----|-----|-----|----|-----|-----|-----|-----|-----|
| | | A | B | C | D | E | F | H | J | L | X° | Z°° |
| G100420 * | 7 - 14 | 259 | 430 | 114 | 101 | 90 | 52 | 205 | 68 | 270 | 373 | 107 |
| G100428 | 7 - 16 | 259 | 430 | 114 | 101 | 90 | 52 | 205 | 68 | 270 | 373 | 107 |
| G110381 " * | 8 - 16 | 279 | 480 | 127 | 114 | 108 | 67 | 191 | 77 | 275 | 373 | 107 |
| G110382 * | 8 - 16 | 279 | 480 | 127 | 114 | 108 | 67 | 191 | 77 | 275 | 373 | 107 |
| G130236 * | 10 - 18 | 330 | 425 | 152 | 127 | 132 | 58 | 216 | 90 | 301 | 365 | 93 |
| G130232 * | 13 - 24 | 330 | 530 | 152 | 127 | 132 | 58 | 216 | 90 | 301 | 470 | 93 |
| G130234 " * | 13 - 24 | 330 | 530 | 152 | 127 | 132 | 58 | 216 | 90 | 301 | 470 | 93 |
| G130233 | 13 - 25 | 330 | 530 | 152 | 127 | 132 | 58 | 216 | 90 | 301 | 470 | 93 |
| G130235 " | 13 - 25 | 330 | 530 | 152 | 127 | 132 | 58 | 216 | 90 | 301 | 470 | 93 |
| G150255 * | 16 - 32 | 381 | 530 | 178 | 152 | 140 | 70 | 242 | 103 | 336 | 480 | 93 |
| G150259 " * | 16 - 32 | 381 | 530 | 178 | 152 | 118 | 70 | 242 | 103 | 336 | 480 | 93 |
| G150256 | 16 - 33 | 381 | 530 | 178 | 152 | 140 | 70 | 242 | 103 | 336 | 480 | 93 |
| G180087 * | 20 - 39 | 457 | 510 | 203 | 178 | 128 | 85 | 290 | 128 | 402 | 460 | 130 |
| G180074 * | 22 - 39 | 457 | 650 | 203 | 178 | 128 | 85 | 290 | 128 | 402 | 600 | 130 |
| G180073 * | 25 - 42 | 457 | 650 | 203 | 203 | 128 | 85 | 290 | 128 | 402 | 600 | 130 |
| G180075 " * | 25 - 42 | 457 | 650 | 203 | 203 | 128 | 85 | 290 | 128 | 402 | 600 | 130 |

" Inlet on opposite side * Includes safety element X° Free space needed to remove main element
Z°° Free space needed to remove cover

Medium Dust Conditions

FRG2 Service Parts

| Service Parts | | | | | | |
|-----------------------|--------------|--------------|--------------------|-----------------|----------|-----------------|
| Air Cleaner Model No. | Main Element | Kit Number • | Access Cover Assy* | Vacuator™ Valve | Rain Cap | Mounting band** |
| G100420 | P785589 | X770689 | P784944 | P776008 | H770012 | P004076 |
| G100428 | P785589 | - | P784944 | P776008 | H770012 | P004076 |
| G110381 | P785396 | X770690 | P784923 | P158914 | H770013 | P004079 |
| G110382 | P785396 | X770690 | P784923 | P158914 | H770013 | P004079 |
| G130232 | P785390 | X770691 | P784892 | P776008 | H770090 | P013722 |
| G130233 | P785390 | - | P784892 | P776008 | H770090 | P013722 |
| G130234 | P785390 | X770691 | P784892 | P776008 | H770090 | P013722 |
| G130235 | P785390 | - | P784892 | P775569 | H770090 | P013722 |
| G130236 | P785398 | X770692 | P784892 | P776008 | H770090 | P013722 |
| G150255 | P785590 | X770693 | P785551 | P776008 | H770089 | P016845 |
| G150256 | P785590 | - | P785551 | P776008 | H770089 | P016845 |
| G150259 | P785590 | X770693 | P785551 | P776008 | H770089 | P016845 |
| G180073 | P785394 | X770688 | P784792 | P105220 | H001053 | H770037 |
| G180074 | P785394 | X770688 | P784792 | P105220 | H001053 | H770037 |
| G180075 | P785394 | X770688 | P784792 | P105220 | H001053 | H770037 |
| G180087 " | P786197 | X770683 | P784792 | P105220 | H001053 | H770037 |

* Spare Part only ** Two mounting band needed per Air Cleaner
 " No restriction indicator tapping point
 • Safety element can only be bought as a kit meaning together with the main element

Medium Dust Conditions

When specifying an Air Cleaner...

Determine the Airflow Requirements of your engine, then find the corresponding m³/min. airflow in the charts below. The restriction numbers - shown in mbar at the left side of the chart - indicate the approximate initial restriction of each model air cleaner at that m³/min. When calculating total initial restriction of the entire air intake system, include the restriction caused by ducting, elbows, pre-cleaners, etc. The estimated lab life hours are indicated at the right side of the chart.

FRG2 Performance Curves

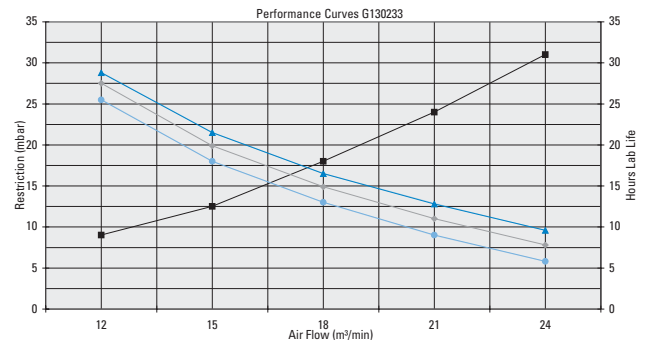
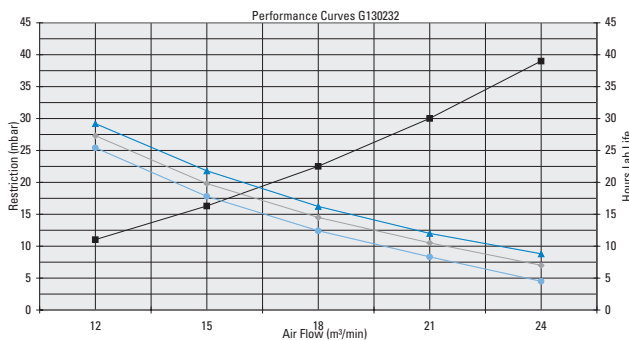
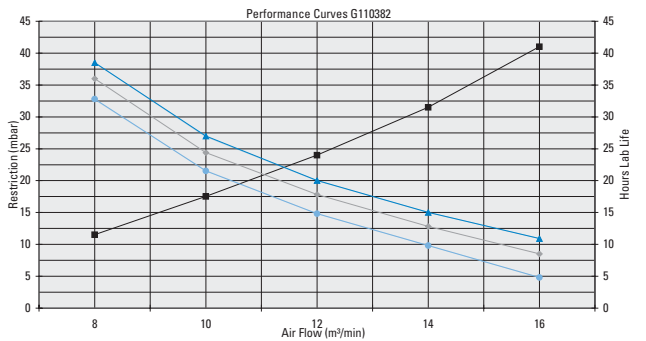
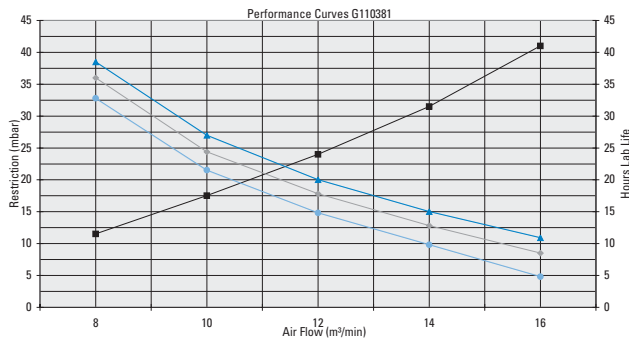
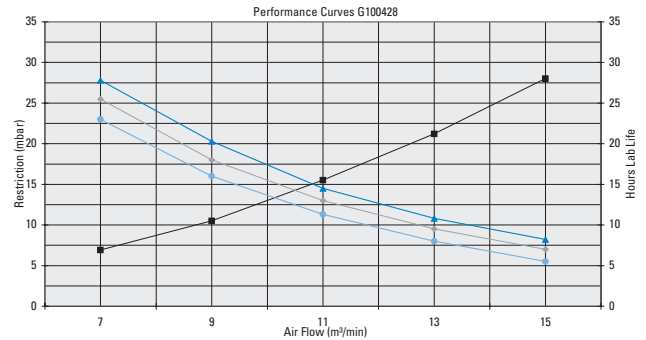
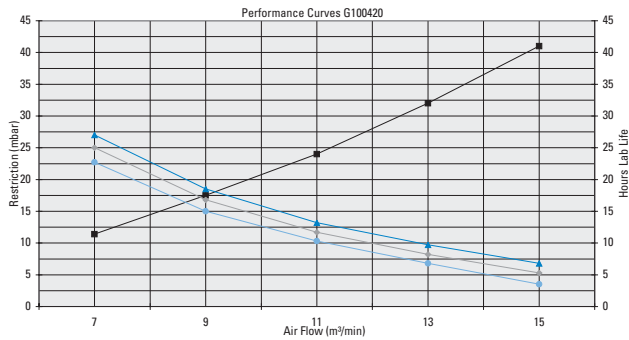

Restr. A/c Piezo
 LL50mbar
 LL62mbar
 LL75mbar

All performance curves are according ISO 5011 standards - Restriction measured at Piezo
 All tests are done with ISO Coarse at Dust Concentration of 1g/m³

FRG2 Performance Curves

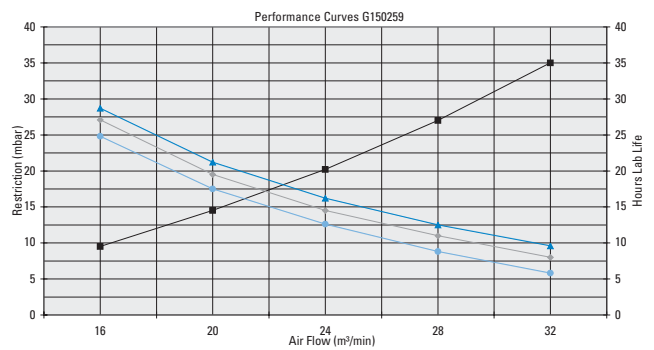
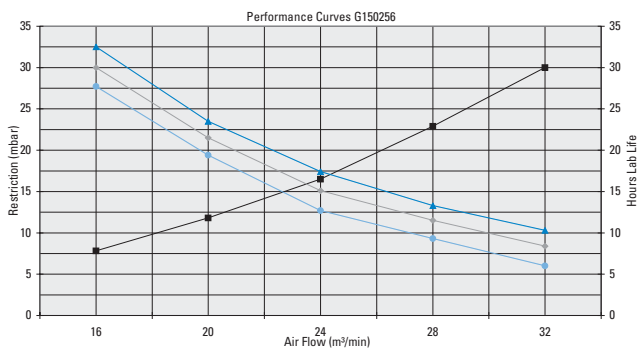
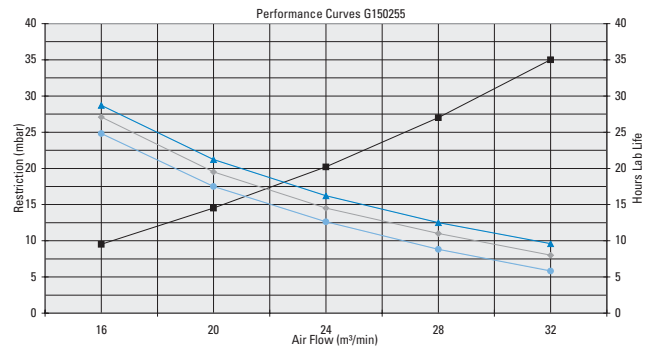
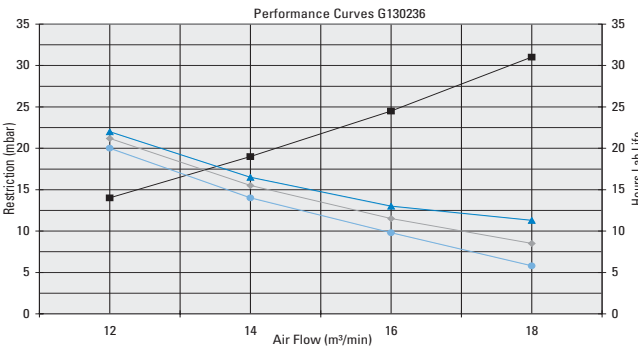
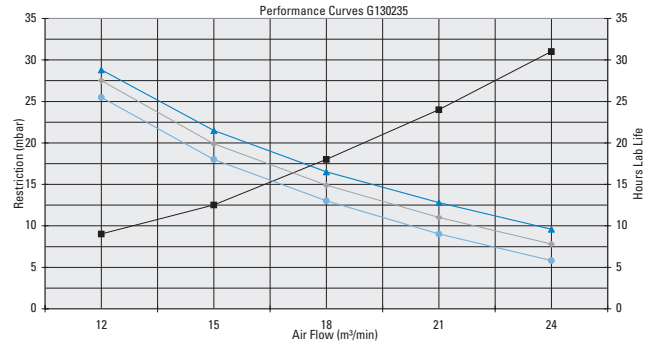
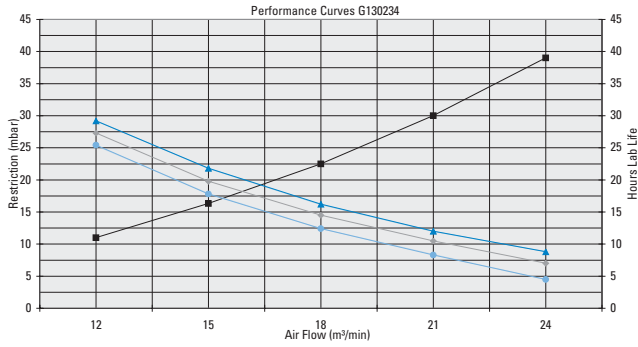

Restr. A/c Piezo
 LL50mbar
 LL62mbar
 LL75mbar

All performance curves are according ISO 5011 standards - Restriction measured at Piezo
 All tests are done with ISO Coarse at Dust Concentration of 1g/m³

Medium Dust Conditions

FRG2 Performance Curves

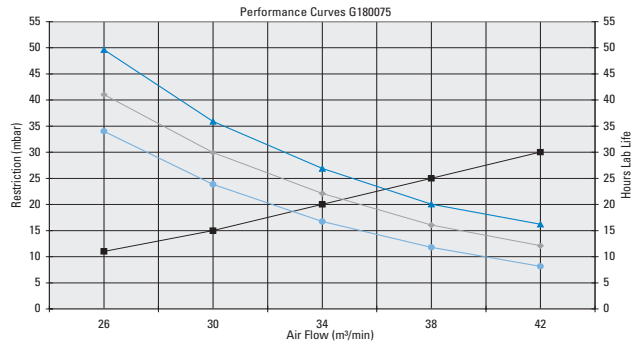
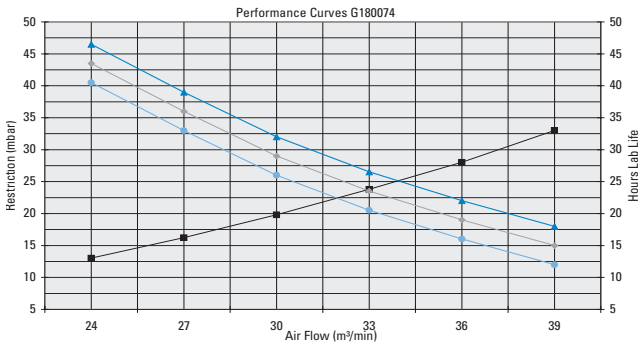
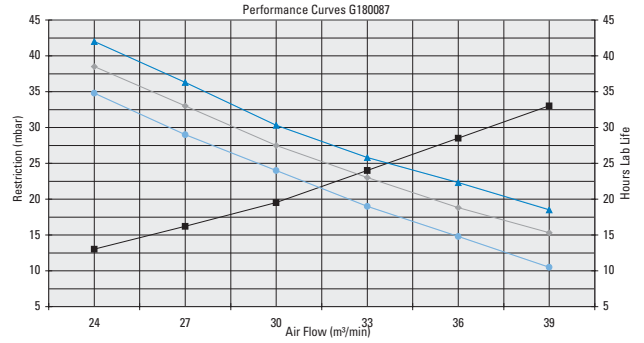
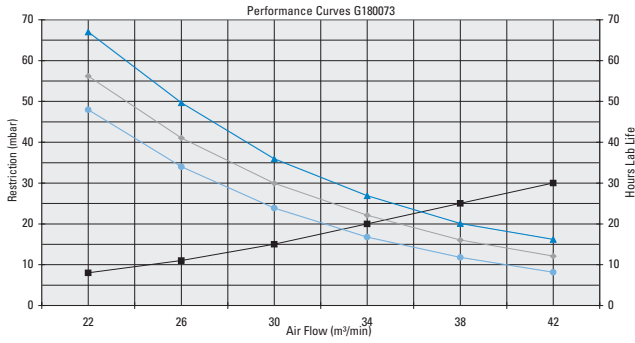

Restr. A/c Piezo
 LL50mbar
 LL62mbar
 LL75mbar

All performance curves are according ISO 5011 standards - Restriction measured at Piezo
 All tests are done with ISO Coarse at Dust Concentration of 1g/m³

1 Remove the Filter

Unfasten or unlatch the service cover.



Rotate the filter while pulling straight out.

Because the filter fits tightly over the outlet tube to create the critical seal, there will be some initial resistance, similar to breaking the seal on a jar. Gently move the end of the filter back and forth to break the seal then rotate while pulling straight out. Avoid knocking the filter against the housing.



If your air cleaner has a safety filter, replace it every third primary filter change. Remove the safety filter as you would the primary filter. Make sure you cover the air cleaner outlet tube to avoid any unfiltered contaminant dropping into the engine.

2 Clean Both Surfaces of the Outlet Tube and Check the Vacuator™ Valve

Use a clean cloth to wipe the filter sealing surface and the inside of the outlet tube. Contaminant on the sealing surface could hinder an effective seal and cause leakage. Make sure that all contaminant is removed before the new filter is inserted. Dirt accidentally transferred to the inside of the outlet tube will reach the engine and cause wear. Engine manufacturers say that it takes only a few grams of dirt to “dust” an engine! Be careful not to damage the sealing area on the tube.

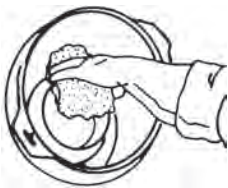

Outer edge of the outlet tube

Wipe both sides of the outlet tube clean.



Inner edge of the outlet tube

If your air cleaner is equipped with a Vacuator Valve

Visually check and physically squeeze to make sure the valve is flexible and not inverted, damaged or plugged.



3 Inspect the Old Filter for Leak Clues

Visually inspect the old filter for any signs of leaks. A streak of dust on the clean side of the filter is a telltale sign. Remove any cause of leaks before installing new filter.

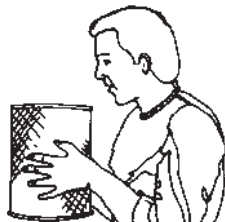

4 Inspect the New Filter for Damage

Inspect the new filter carefully, paying attention to the inside of the open end, which is the sealing area.

NEVER install a damaged filter. A new Donaldson radial seal filter may have a dry lubricant on the seal to aid installation.



5 Insert the New Radial Seal Filter Properly

If you're servicing the safety filter, this should be seated into position before installing the primary filter.

Insert the new filter carefully. Seat the filter by hand, making certain it is completely into the air cleaner housing before securing the cover in place.

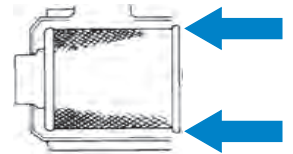

The critical sealing area will stretch slightly, adjust itself and distribute the sealing pressure evenly. To complete a tight seal, apply pressure by hand at the outer rim of the filter, not the flexible center. Avoid pushing on the center of the urethane end cap. No cover pressure is required to hold the seal. NEVER use the service cover to push the filter into place! Using the cover to push the filter in could cause damage to the housing, cover fasteners and will void the warranty.

If the service cover hits the filter before it is fully in place, remove the cover and push the filter (by hand) further into the air cleaner and try again. The cover should go on with no extra force.

Once the filter is in place, secure the service cover.



Caution
NEVER use the service cover to push the filter into place! Using the cover to push the filter in could cause damage to the housing, cover fasteners and will void the warranty.



6 Check Connectors for Tight Fit

Make sure that all mounting bands, clamps, bolts, and connections in the entire air cleaner system are tight. Check for holes in piping and repair if needed. Any leaks in your intake piping will send dust directly to the engine!

Air Cleaners used in Heavy Dust Conditions

... Donaldson offers a full line of air cleaners for a wide variety of applications and operating environments.

Section Index

| | |
|--|-----|
| FLB..... | 90 |
| FLB Service Instructions..... | 92 |
| EPB-ERB2 with Donaspin™ Pre-Cleaner..... | 93 |
| EPB-ERB2 with Strata™ Pre-Cleaner..... | 95 |
| SPB2..... | 97 |
| SRB..... | 100 |
| SPB2-SRB Service Instructions..... | 103 |
| SSG Donaclone™..... | 104 |
| SSG Service Instructions..... | 110 |
| STG Donaclone™..... | 111 |
| STG Service Instructions..... | 117 |

**UNIQUE
DESIGN
CONCEPT**

Two-Stage Louvered Body Air Cleaner



The FLB - Louvered Body Air Cleaner is a two-stage air cleaner with scavenge exhaust system and Axial Seal Sealing Technology. Body diameters in 6", 8", 10" and 12". Handles airflows of 3-17 m³/min. Sustained temperature tolerance: to 82°C.

Designed especially for combines and other heavy-duty construction and agricultural equipment operating in severe dust, fibers, lint and shaft environments. To be used with an exhaust ejector. For all available Donaldson Exhaust Ejectors, see page 124-125.

FLB Specifications - Service Parts

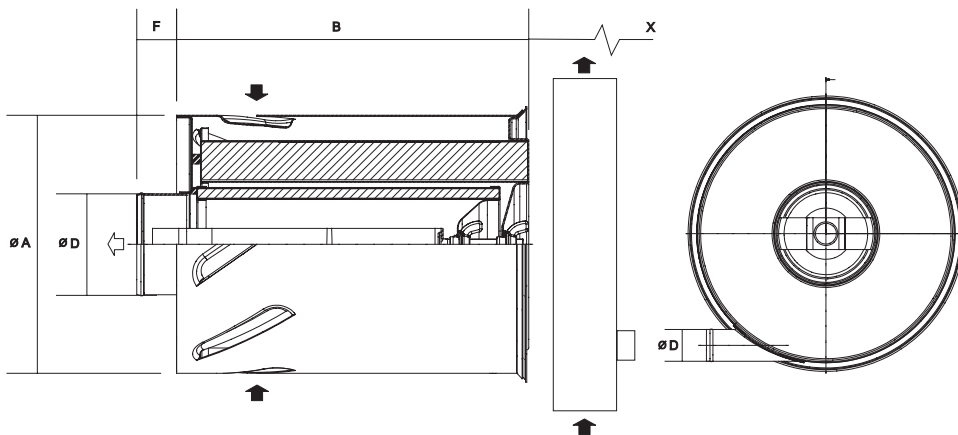

| Air Cleaner Model No | Airflow Range m ³ /min. | Dimensions (mm) | | | | | |
|----------------------|------------------------------------|-----------------|-----|-----|----|----|-----|
| | | A | B | D | F | G | X° |
| B065018 | 3 - 5 | 167 | 360 | 76 | 28 | 32 | 345 |
| B080022 | 4,5 - 7 | 203 | 423 | 89 | 54 | 32 | 415 |
| B100067 | 7 - 12 | 259 | 430 | 101 | 50 | 32 | 425 |
| B120260 | 12 - 17 | 300 | 424 | 127 | 80 | 32 | 415 |

X° Free space needed to remove main element

| Air Cleaner Model No. | Service Parts | | | |
|-----------------------|---------------|----------------|----------------|-----------------|
| | Main Element | Safety Element | Mounting Band* | Filter Wing Nut |
| B065018 | P772565 | P770207 | P007191 | P138403 |
| B080022 | P772556 | P119410 | P004307 | P138403 |
| B100067 | P772530 | P133138 | P004076 | P138403 |
| B120260 | P772520 | P770678 | H000349 | P134803 |

* Two mounting bands needed per Air Cleaner

When specifying an Air Cleaner...

Determine the Airflow Requirements of your engine, then find the corresponding m³/min. airflow in the charts below. The restriction numbers - shown in mbar at the left side of the chart - indicate the approximate initial restriction of each model air cleaner at that m³/min. When calculating total initial restriction of the entire air intake system, include the restriction caused by ducting, elbows, pre-cleaners, etc. The estimated lab life hours are indicated at the right side of the chart.

FLB Performance Curves

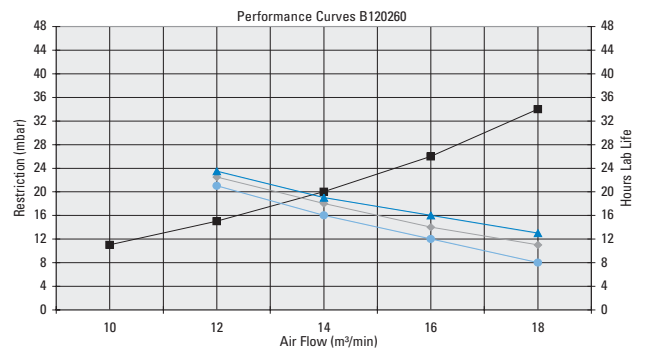
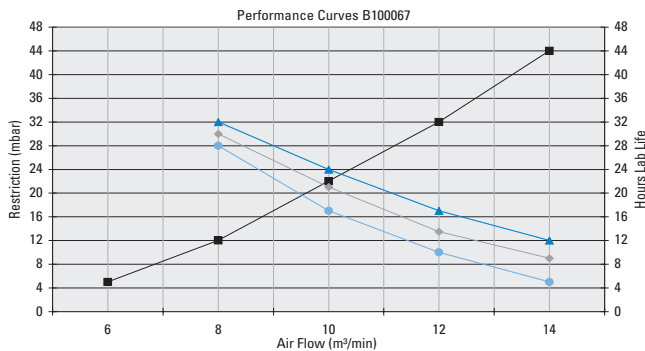
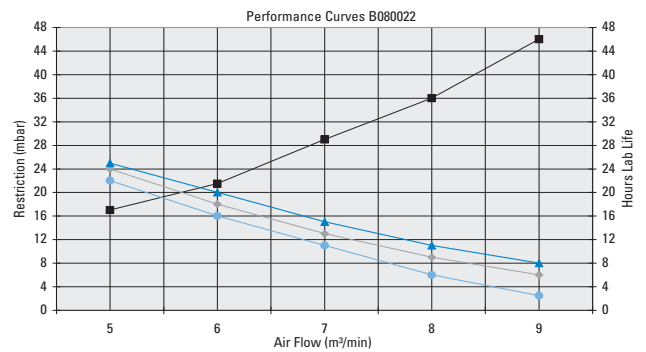
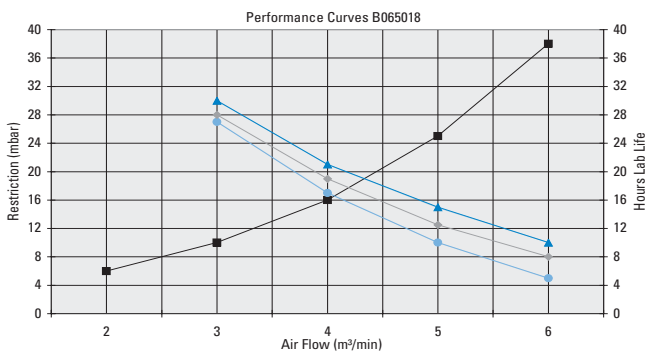

Restr. A/c Piezo
 LL50mbar
 LL62mbar
 LL75mbar

All performance curves are according ISO 5011 standards - Restriction measured at Piezo
 All tests are done with ISO Coarse at Dust Concentration of 1g/m³

1 Remove the old filter gently

"Baby" that dirty filter, until you get it clear of the housing. Accidentally bumping it while still inside means dropped dirt and dust that will contaminate the clean side of your filter housing, before the new filter element has a chance to do its job.



2 Always clean the inside of the housing carefully

Dirt left in the air cleaner housing spells death for your engine. Use a clean, damp cloth to wipe every surface clean. Check it visually to make sure it's clean before putting in a new filter.



3 Always clean the gasket sealing surfaces

An improper gasket seal is one of the most common causes of engine contamination. Make sure that all hardened dirt ridges are completely removed, both on the bottom and top of the air cleaner housing.



4 Check for uneven dirt patterns

Your old filter has valuable clues to dust leakage or gasket sealing problems. A pattern on the filter clean side is a sign that the old filter was not firmly sealed or that a dust leak exists. Identify the cause of that leak and rectify it before installing a new filter.



5 Press your fresh gasket to see that it springs back

Make sure your new filter is made with a highly compressible gasket that springs back (promptly) when finger pressure is released. A high quality gasket is one of the most important parts of the filter.



6 Make sure the gasket seats evenly

If you don't feel the gasket seating evenly for a perfect seal, you don't have protection. Re-check to see if the sealing surface in the housing is clean, and ensure that the filter is the correct model. It may be the wrong size for the housing.



7 Ensure air-tight fit on all connections and ducts

Check that all clamps and flange joints are tight, as well as the air cleaner mounting bolts. Seal any leaks immediately - leaks mean dirt is directly entering your engine.



Specifications



See page 130 for the Donaspin™ Pre-Cleaners



See page 44-45 for EPB-ERB2 Service Parts.

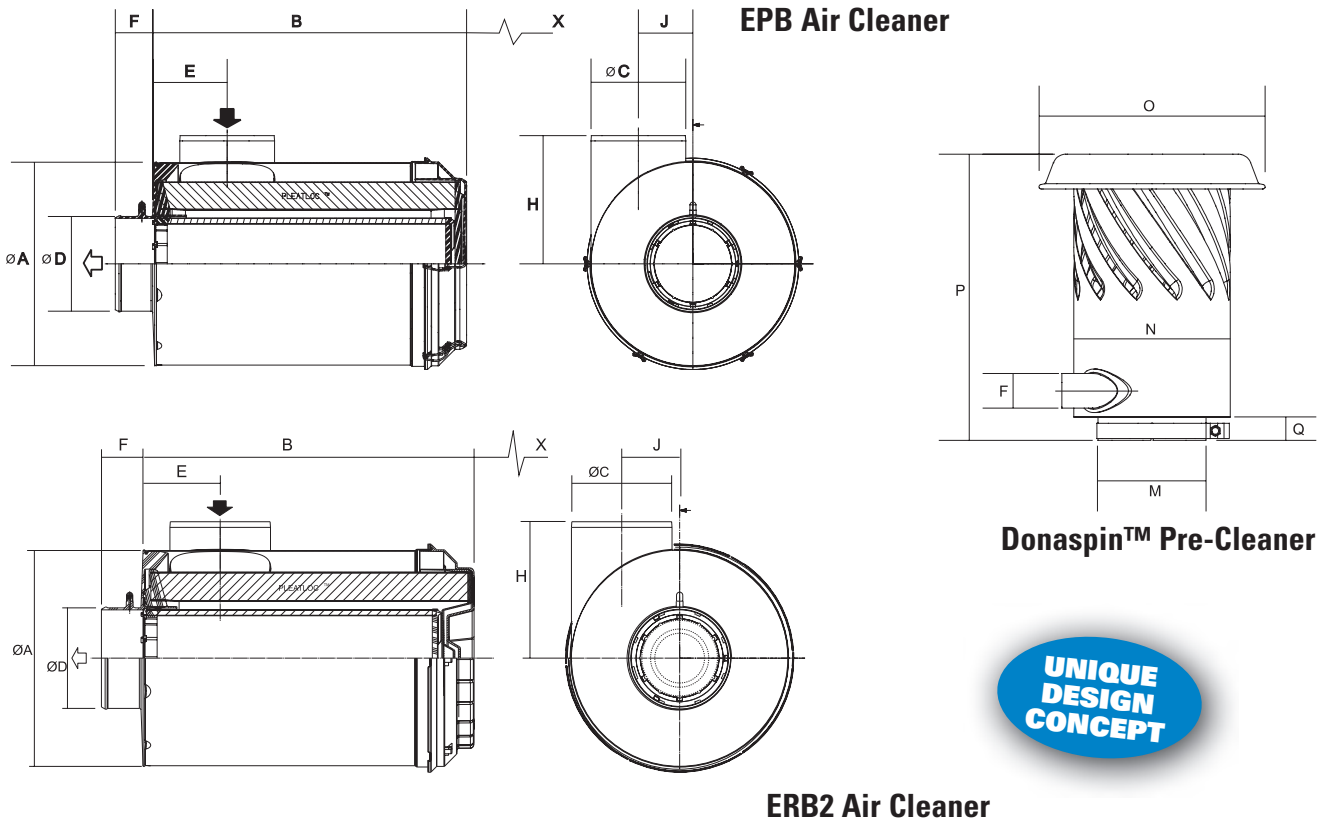

| Style | Air Cleaner Model No. | Airflow Range m ³ /min. | Dimensions (mm) | | | | | | | | | | Pre-Cleaner | M | N | O | P | Q |
|-------|-----------------------|------------------------------------|-----------------|-----|-----|-----|-----|------|-----|-----|-----|---------|-------------|-----|-----|-----|----|---|
| | | | A | B | C | D | E | F | H | J | X° | | | | | | | |
| EPB | B070005 | 2 - 5 | 182 | 334 | 76 | 76 | 45 | 27 | 115 | 145 | 340 | H001212 | 77 | 203 | 305 | 316 | 55 | |
| EPB | B080067 | 4 - 7 | 210 | 355 | 95 | 89 | 54 | 31,5 | 130 | 146 | 355 | H001307 | 95 | 203 | 305 | 304 | 42 | |
| ERB2 | B100126 | 7 - 12 | 259 | 430 | 114 | 102 | 143 | 52 | 205 | 0 | 400 | H001215 | 114 | 203 | 305 | 290 | 28 | |

X ° Free space needed to remove main element
 For all available Donaldson Exhaust Ejectors, see page 124-125

EPB - ERB2 Air Cleaner with Donaspin™ Pre-Cleaner



When specifying an Air Cleaner...

Determine the Airflow Requirements of your engine, then find the corresponding $m^3/min.$ airflow in the charts below. The restriction numbers - shown in mbar - indicate the approximate initial restriction of each model air cleaner at that $m^3/min.$ If there are two air cleaner models that fit your parameters, choosing the one with the lowest restriction will provide the longest service life. When calculating total initial restriction of the entire air intake system, include the restriction caused by ducting, elbows, pre-cleaners, etc.

Restriction Curves

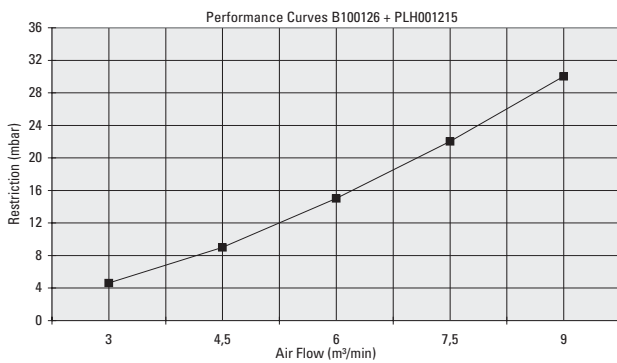
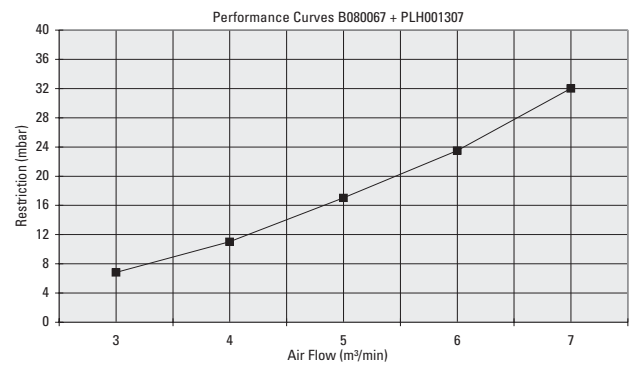
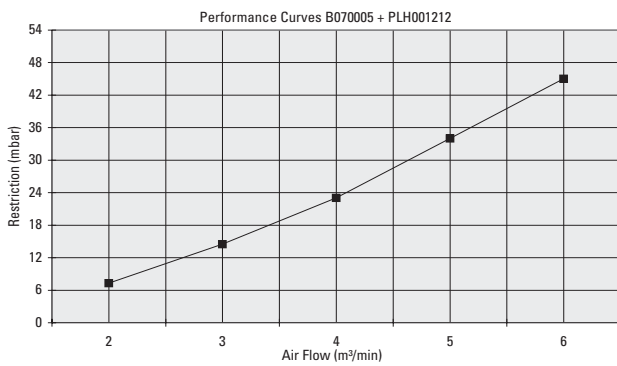

—■— Restr. A/c Piezo

All performance curves are according ISO 5011 standards - Restriction measured at Piezo
All tests are done with ISO Coarse at Dust Concentration of $1g/m^3$

Specifications



For more details on the Strata™ Pre-Cleaner, contact your Donaldson representative.



See page 44-45 for EPB-ERB2 Service Parts.

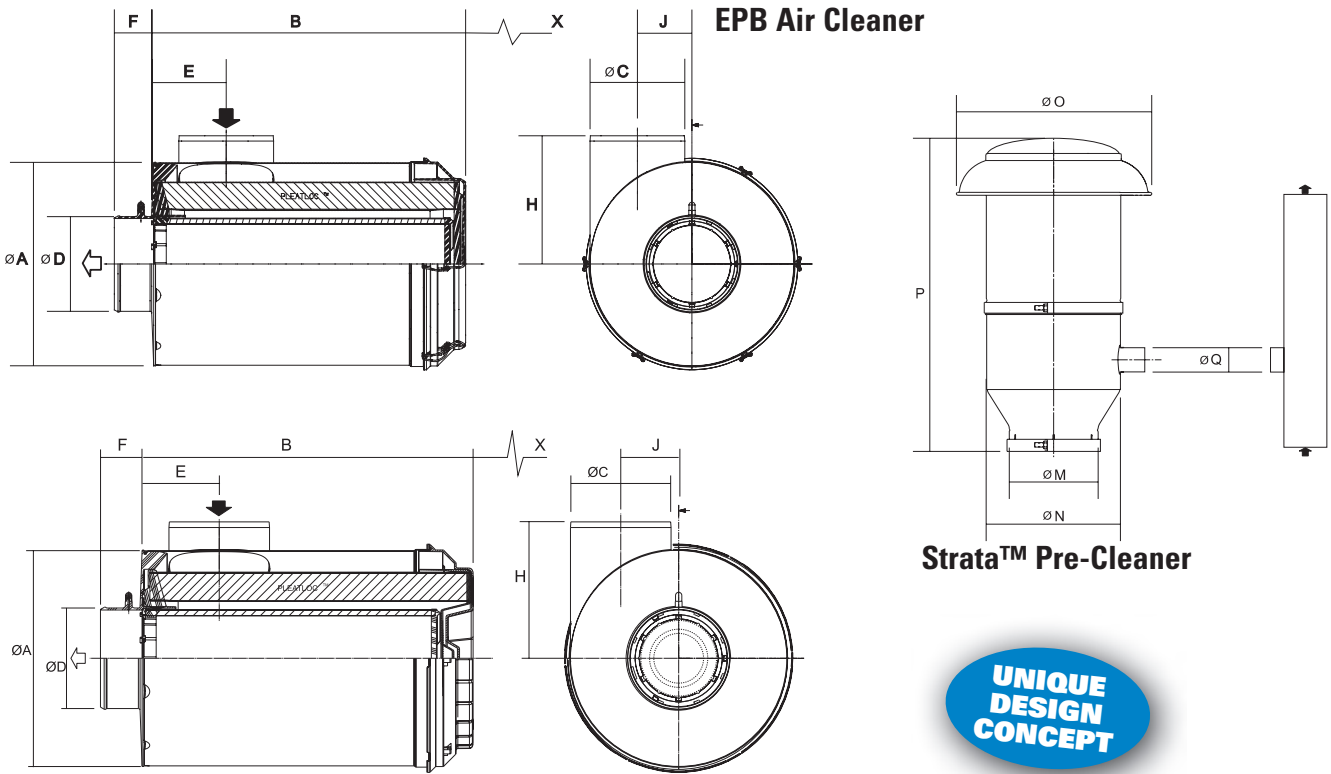

ERB2 Air Cleaner

| Style | Air Cleaner Model No. | Airflow Range m ³ /min. | Dimensions (mm) | | | | | | | | | | Pre-Cleaner | M | N | O | P | Q |
|-------|-----------------------|------------------------------------|-----------------|-----|-----|-----|-----|------|-----|-----|-----|---------|-------------|-----|-----|-----|----|---|
| | | | A | B | C | D | E | F | H | J | X° | | | | | | | |
| EPB | B070005 | 2 - 4 | 182 | 334 | 76 | 76 | 45 | 27 | 115 | 145 | 340 | H000975 | 78 | 167 | 281 | 441 | 25 | |
| EPB | B080067 | 4 - 7 | 210 | 355 | 95 | 89 | 54 | 31,5 | 130 | 146 | 355 | H000896 | 97 | 167 | 281 | 447 | 25 | |
| ERB2 | B100126 | 7 - 12 | 259 | 430 | 114 | 102 | 143 | 52 | 205 | 0 | 400 | H001510 | 116 | 167 | 281 | 441 | 25 | |
| ERB2 | B130013 | 15 - 26 | 330 | 530 | 178 | 152 | 180 | 58 | 215 | 0 | 360 | H001148 | 179 | 279 | 406 | 465 | 38 | |
| ERB2 | B150025 | 18 - 32 | 381 | 590 | 178 | 178 | 136 | 70 | 241 | 102 | 540 | H001148 | 179 | 279 | 406 | 465 | 38 | |

X° Free space needed to remove main element
 For all available Donaldson Exhaust Ejectors, see page 124-125

EPB - ERB2 Air Cleaner with Strata™ Pre-Cleaner



When specifying an Air Cleaner...

Determine the Airflow Requirements of your engine, then find the corresponding m³/min. airflow in the charts below. The restriction numbers - shown in mbar - indicate the approximate initial restriction of each model air cleaner at that m³/min. If there are two air cleaner models that fit your parameters, choosing the one with the lowest restriction will provide the longest service life. When calculating total initial restriction of the entire air intake system, include the restriction caused by ducting, elbows, pre-cleaners, etc.

Restriction Curves

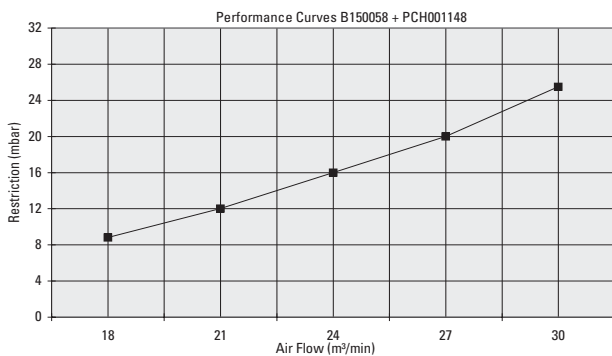
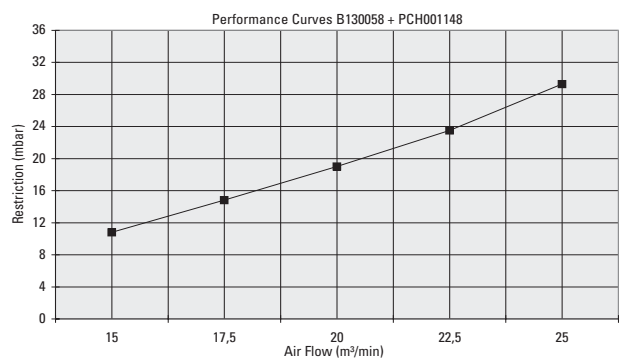
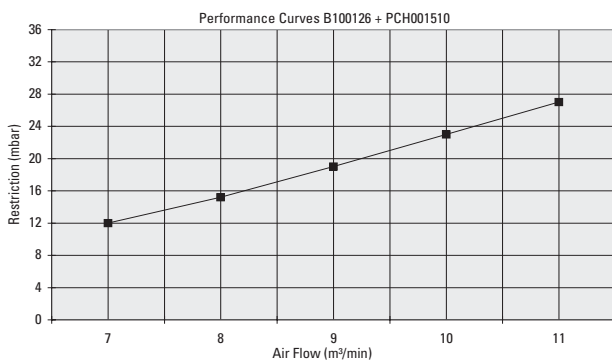
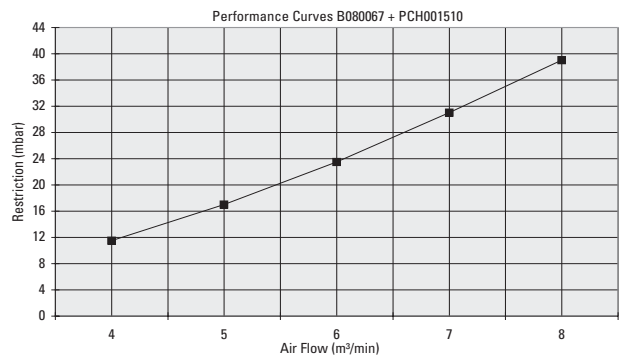
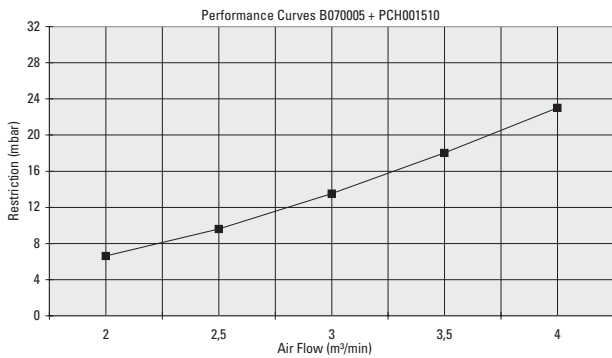

—■— Restr. A/c Piezo

All performance curves are according ISO 5011 standards - Restriction measured at Piezo
All tests are done with ISO Coarse at Dust Concentration of 1g/m³

Two-Stage RadialSeal™ Air Cleaners which offer improved reliability and durability, reduced weight and costs and better serviceability

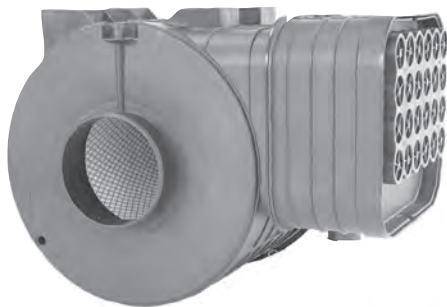

The SPB2 Air Cleaner is a two-stage full plastic air cleaner with built-in high efficiency Pre-Cleaner and RadialSeal™ Sealing Technology. They are suitable for agricultural and construction equipment operating in severe dust environments. To be used with an exhaust ejector. For all available Donaldson Exhaust Ejectors, see page 124-125.



The SPB2 Air Cleaner Products are featuring the Donaldson's Unique Design Concept. For more details on this UDC Feature, see page 7.

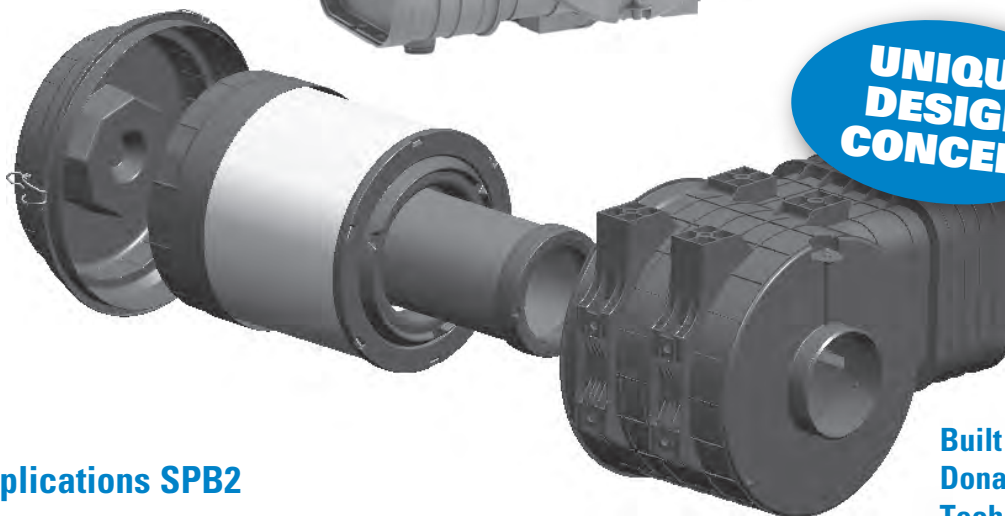

**UNIQUE
DESIGN
CONCEPT**

**Built with
Donaldson
Technology.**

Applications SPB2

- Can be mounted vertically or horizontally
- Provides variety of airflow volumes to engine: from 6 to 22 m³/min.
- Temperature tolerance: to 83°C continuous / 105°C intermittent

Features SPB2

- Body diameter of 13"
- Cost effective / Compact and light weight
- Flexible installation
- Reliable, durable, high-tech and easy to service design
- Proven RadialSeal™ Technology
- Tapped for restriction indicator as standard
- Built-in Strata™ Pre-Cleaner with efficiency of 90 - 93%
- Always to be used with a scavenge system (minimum with 10% scavenge)
- ISO Coarse Dust / ISO 5011 Certificate
- Indicator thread size = 1/8-27NPT (MALE)

SPB2 Specifications

B130048

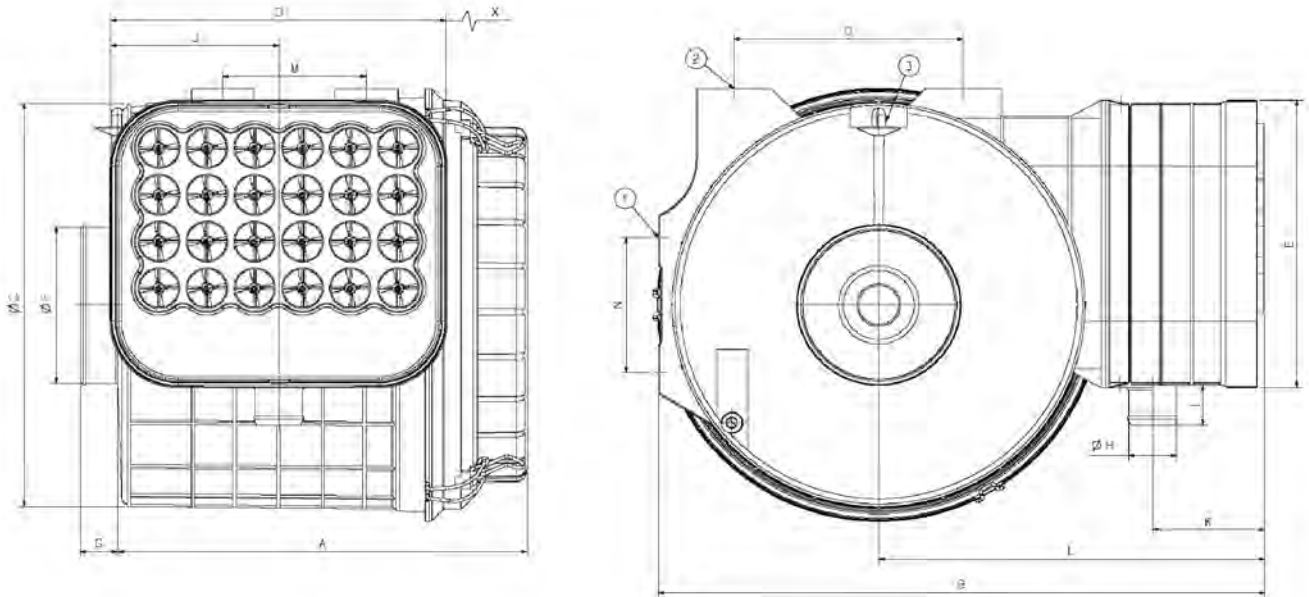

B130060

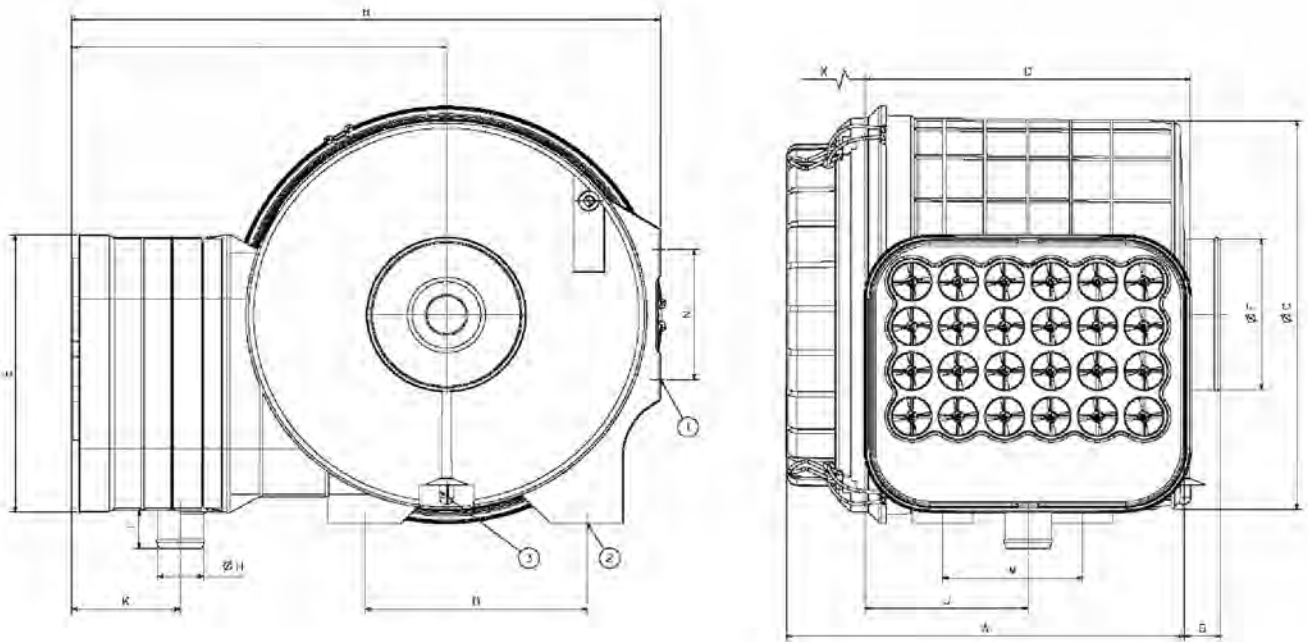

- 1) 4 Clips M8 optional – Reference P784517: Plastic bag with 4 U-Clips
- 2) Insert M8
- 3) 1/8 27 NPT

SPB2 Specifications - Service Parts

| B130048 + B130060 Dimensions (mm) | | | | | | | | | | | | | | | | |
|--------------------------------------|-----|-----|-----|-----|-----|----|----|----|-----|----|-----|-----|-----|-----|----|-----|
| A | B | C | D | E | F | G | H | I | J | K | L | M | N | O | X | Z |
| 325 | 481 | 328 | 266 | 234 | 127 | 30 | 38 | 33 | 133 | 89 | 306 | 114 | 110 | 182 | 75 | 280 |

X Free space needed to remove main element
 Z Free space needed to remove cover Airflow = 6-22 m³/min.

| Service Parts | | | | |
|-----------------------|--------------|--------------|--------------------|-----------------|
| Air Cleaner Model No. | Main Element | Kit Number • | Access Cover Assy* | Mounting band** |
| B130048 " | P783543 | X770684 | P783693 | Integrated |
| B130060 " | P783543 | X770684 | P783693 | Integrated |

* Spare Part only ** Two mounting bands needed per air cleaner " Inlet 180° rotated
 • Safety Element can only be bought as a kit meaning together with the main element
 For all available Exhaust Ejectors, see page 124-125

When specifying an Air Cleaner...

Determine the Airflow Requirements of your engine, then find the corresponding m³/min. airflow in the charts below. The restriction numbers - shown in mbar at the left side of the chart - indicate the approximate initial restriction of each model air cleaner at that m³/min. When calculating total initial restriction of the entire air intake system, include the restriction caused by ducting, elbows, pre-cleaners, etc. The estimated lab life hours are indicated at the right side of the chart.

SPB2 Performance Curves

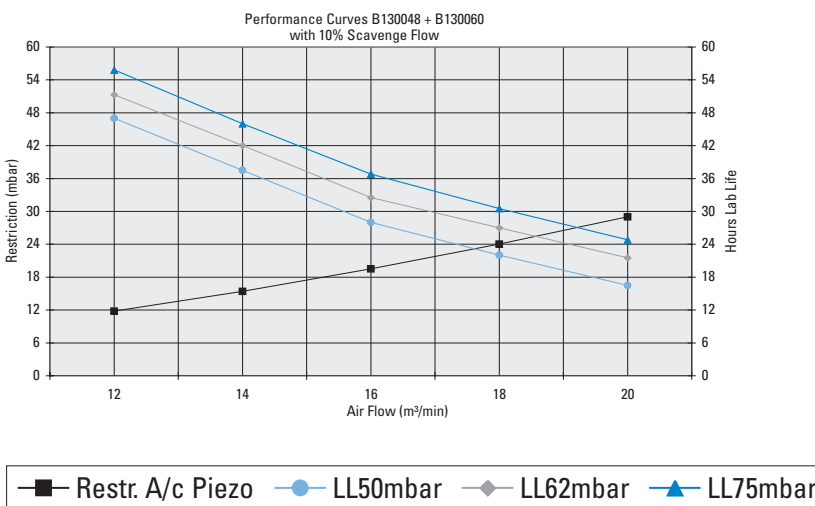

All performance curves are according ISO 5011 standards - Restriction measured at Piezo
 All tests are done with ISO Coarse at Dust Concentration of 1g/m³

Two-Stage RadialSeal™ Air Cleaners which offer improved reliability and durability, reduced weight and costs and better serviceability.



The SRB Air Cleaner is a two-stage hybrid air cleaner with built-in high efficiency Pre-Cleaner and RadialSeal™ Sealing Technology.

They are suitable for agricultural and construction equipment operating in severe dust environments.

To be used with an exhaust ejector. For all available Donaldson Exhaust Ejectors, see page 124.125.

Applications SRB

- Can be mounted vertically or horizontally
- Provides variety of airflow volumes to engine: from 4 to 18 m³/min.
- Temperature tolerance: to 83°C continuous / 105°C intermittent.

Features SRB

- Body diameter of 9", 10", 11" and 13".
- Cost effective / Compact and light weight
- Flexible installation
- Reliable, durable, high-tech and easy to service design
- Proven RadialSeal™ Technology
- Tapped for restriction indicator as standard
- Built-in Strata™ Pre-Cleaner with efficiency of 90 - 93%
- Always to be used with a scavenge system (minimum with 10% scavenge)
- ISO Coarse Dust / ISO5011 Certificate
- Indicator thread size = 1/8-27NPT (MALE)

SRB Specifications - Service Parts

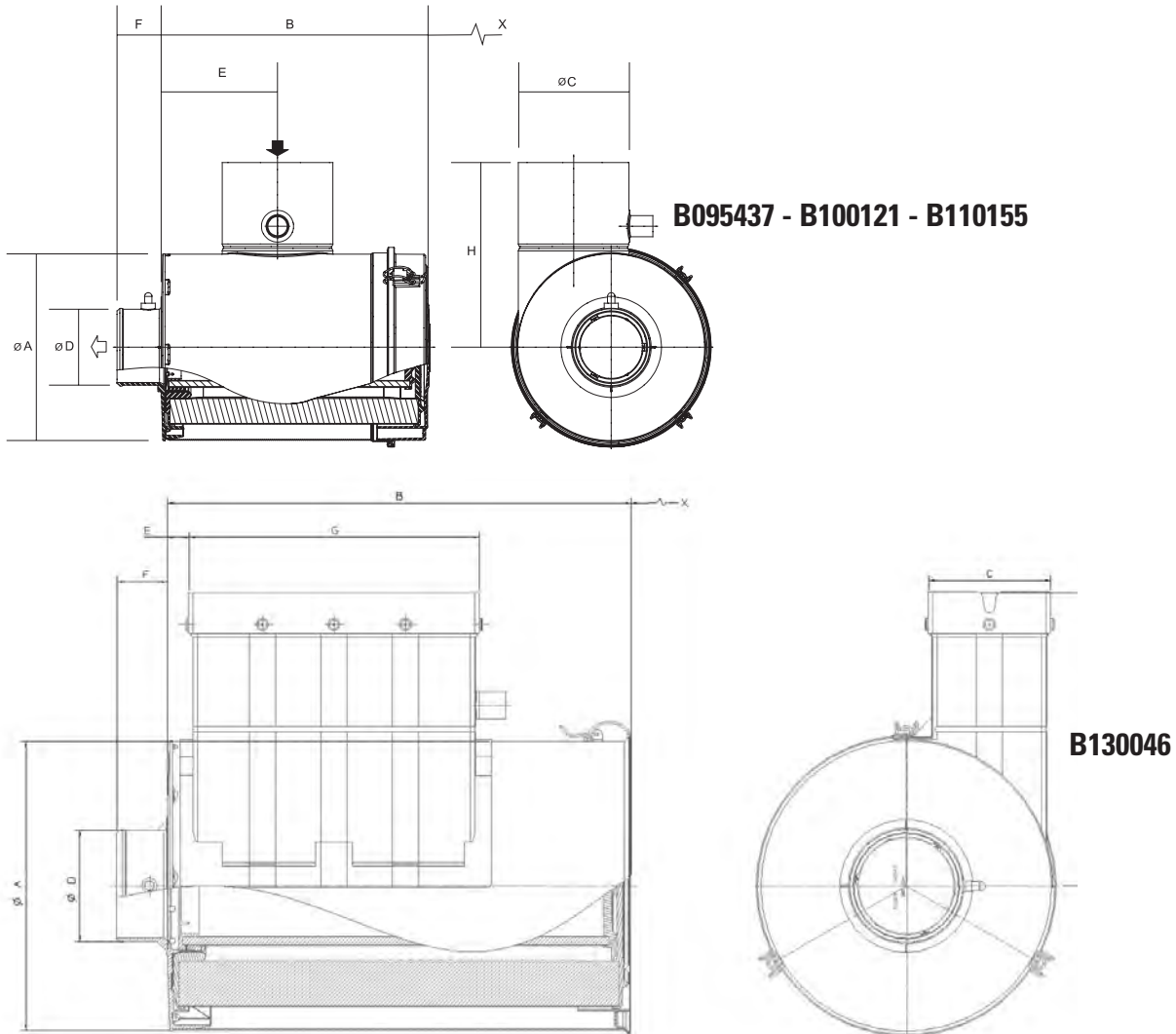

| Air Cleaner Model No. | Airflow Range m ³ /min. | Dimensions (mm) | | | | | | | | | |
|---|------------------------------------|-----------------|-----|---------------------------------------|-----|-----|----|------------|-----|----|-----|
| | | A | B | C | D | E | F | G | H | X° | Z°° |
| B095437" | 4 - 8 | 229 | 400 | 166 | 102 | 203 | 61 | - | 268 | 75 | 380 |
| B100121 | 8 - 12 | 259 | 430 | 166 | 102 | 179 | 52 | - | 268 | 75 | 380 |
| B110155 | 11 - 15 | 279 | 480 | 166 | 114 | 175 | 67 | - | 278 | 75 | 380 |
| B130046 | 13 - 18 | 330 | 530 | 140 | 127 | 25 | 58 | 332 | 335 | 60 | 530 |
| X° Free space needed to remove main element | | | | Z°° Free space needed to remove cover | | | | "90° elbow | | | |

| Air Cleaner Model No. | Main Element | Safety Element | Access Cover Assy* | Mounting band** |
|-----------------------|--------------|--|--------------------|-----------------|
| B095437 | P780522 | P780523 | P782176 | P004073 |
| B100121 | P771039 | P777639 | P777998 | P004076 |
| B110155 | P778905 | P778906 | P783014 | P004079 |
| B130046 | P777279 | P777414 | P781124 | P013722 |
| * Spare Part only | | ** Two mounting bands needed per Air Cleaner | | |

When specifying an Air Cleaner...

Determine the Airflow Requirements of your engine, then find the corresponding m³/min. airflow in the charts below. The restriction numbers - shown in kPa at the left side of the chart - indicate the approximate initial restriction of each model air cleaner at that m³/min. When calculating total initial restriction of the entire air intake system, include the restriction caused by ducting, elbows, pre-cleaners, etc. The estimated lab life hours are indicated at the right side of the chart.

SRB Performance Curves

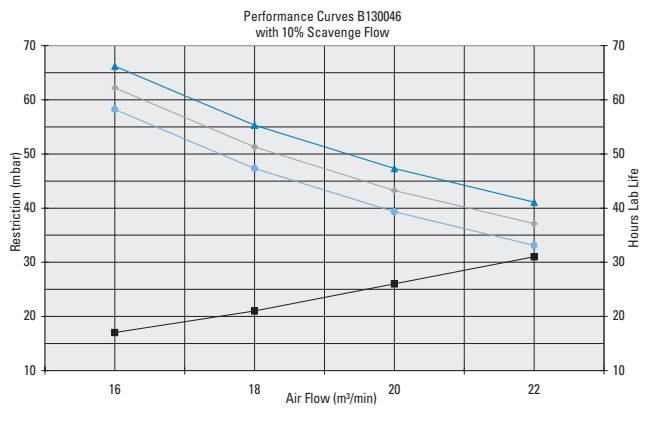
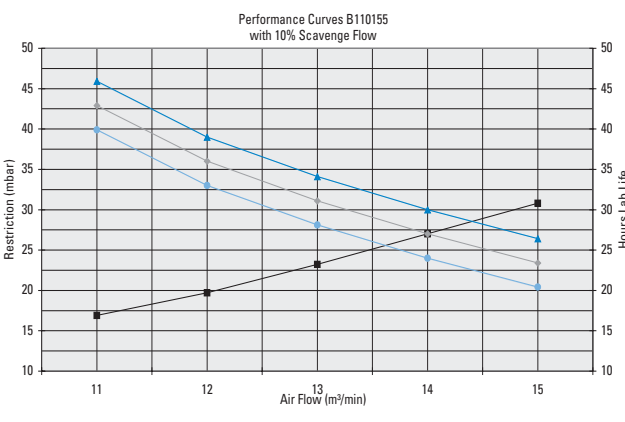
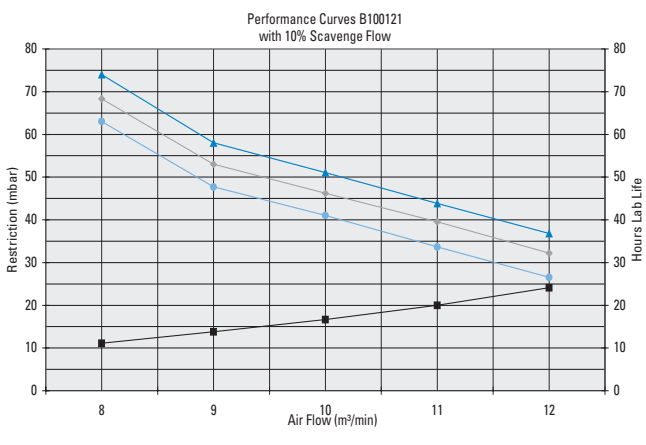
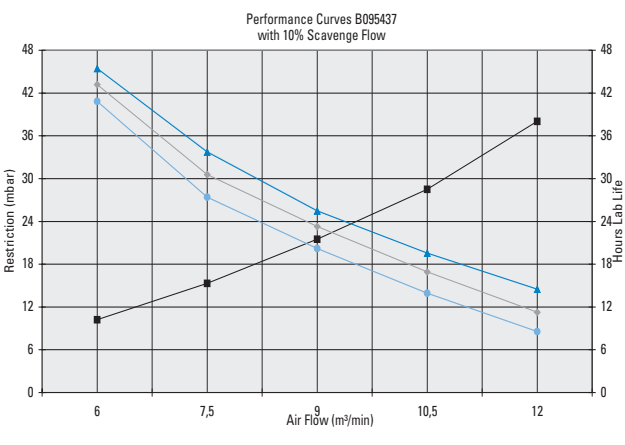

All performance curves are according ISO 5011 standards - Restriction measured at Piezo
 All tests are done with ISO Coarse at Dust Concentration of 1g/m³

1 Remove the Filter

Unfasten or unlatch the service cover.



Rotate the filter while pulling straight out.

Because the filter fits tightly over the outlet tube to create the critical seal, there will be some initial resistance, similar to breaking the seal on a jar. Gently move the end of the filter back and forth to break the seal then rotate while pulling straight out. Avoid knocking the filter against the housing.



If your air cleaner has a safety filter, replace it every third primary filter change. Remove the safety filter as you would the primary filter. Make sure you cover the air cleaner outlet tube to avoid any unfiltered contaminant dropping into the engine.

2 Clean Both Surfaces of the Outlet Tube and Check the Vacuator™ Valve

Use a clean cloth to wipe the filter sealing surface and the inside of the outlet tube. Contaminant on the sealing surface could hinder an effective seal and cause leakage. Make sure that all contaminant is removed before the new filter is inserted. Dirt accidentally transferred to the inside of the outlet tube will reach the engine and cause wear. Engine manufacturers say that it takes only a few grams of dirt to "dust" an engine! Be careful not to damage the sealing area on the tube.

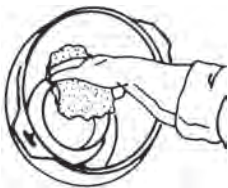

Outer edge of the outlet tube

Wipe both sides of the outlet tube clean.



Inner edge of the outlet tube

If your air cleaner is equipped with a Vacuator Valve Visually check and physically squeeze to make sure the valve is flexible and not inverted, damaged or plugged.



3 Inspect the Old Filter for Leak Clues

Visually inspect the old filter for any signs of leaks. A streak of dust on the clean side of the filter is a telltale sign. Remove any cause of leaks before installing new filter.



4 Inspect the New Filter for Damage

Inspect the new filter carefully, paying attention to the inside of the open end, which is the sealing area.

NEVER install a damaged filter. A new Donaldson radial seal filter may have a dry lubricant on the seal to aid installation.

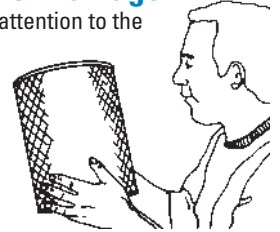

5 Insert the New Radial Seal Filter Properly

If you're servicing the safety filter, this should be seated into position before installing the primary filter.

Insert the new filter carefully. Seat the filter by hand, making certain it is completely into the air cleaner housing before securing the cover in place.

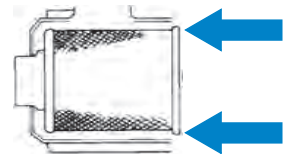

The critical sealing area will stretch slightly, adjust itself and distribute the sealing pressure evenly. To complete a tight seal, apply pressure by hand at the outer rim of the filter, not the flexible center. Avoid pushing on the center of the urethane end cap. No cover pressure is required to hold the seal. NEVER use the service cover to push the filter into place! Using the cover to push the filter in could cause damage to the housing, cover fasteners and will void the warranty.

If the service cover hits the filter before it is fully in place, remove the cover and push the filter (by hand) further into the air cleaner and try again. The cover should go on with no extra force.

Once the filter is in place, secure the service cover.

Caution

NEVER use the service cover to push the filter into place! Using the cover to push the filter in could cause damage to the housing, cover fasteners and will void the warranty.



6 Check Connectors for Tight Fit

Make sure that all mounting bands, clamps, bolts, and connections in the entire air cleaner system are tight. Check for holes in piping and repair if needed. Any leaks in your intake piping will send dust directly to the engine!

Designed for the Worst Dust Conditions New Choice for Construction and Off-Highway Applications

The SSG Air Cleaner offers design improvements and therefore replaces our older SRG Air Cleaner models.

| SRG Model | SSG Model |
|-----------|-----------|
| G200008 | G200087 |
| G200013 | G200086 |
| G290000 | G290057 |
| G290023 | G290052 |
| G290012 | G290053 |

Design Improvements

- The SSG Air Cleaner has filters that use RadialSeal™ Sealing Technology, compared to axial seal style filters. This single design improvement eliminates the need to replace filter and cover gaskets - less service time and fewer parts to inventory.

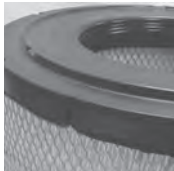

- The access cover for filter service now has quick release cover latches and a chain that connects the air cleaner service cover to the housing!

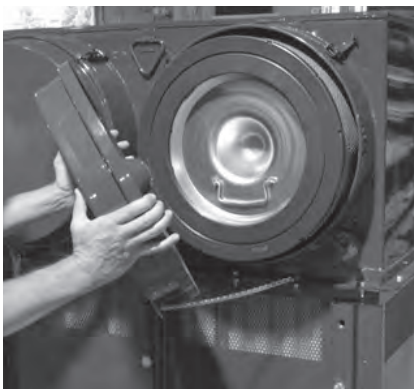

The large, massive mining vehicle in the picture above is an ideal match for the Donaldson SSG Air Cleaner.

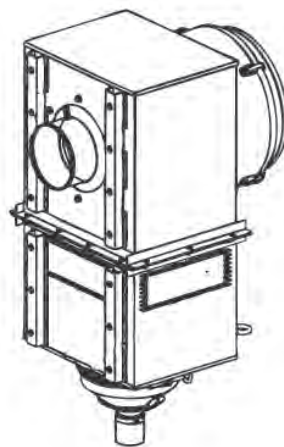

Mounting (back) side view of an SSG 20 model

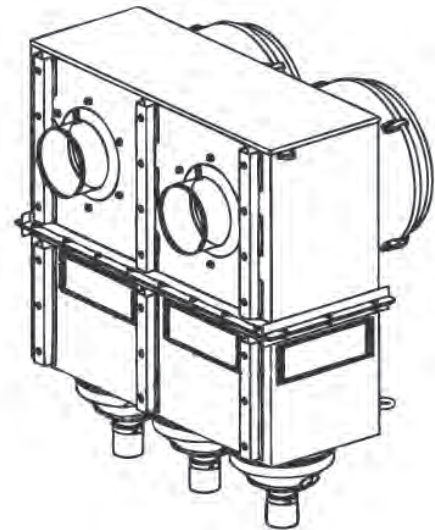

Mounting (back) side view of an SSG 29 model

Covered by issued and pending patents, both U.S. and Internationally

Versatile SSG Provides Airflow to 135 m³/min. With Improved Design Features Compared to our Older SRG Model

Applications

- Allows 48 to 68 m³/min. airflow throughput for the SSG 20 model and 73 to 135 m³/min. airflow throughput for the SSG 29 models
- Horizontal installation
- Off-road, heavy or extreme dust conditions
- Ideal for scrapers, earth movers, graders

Air Cleaner Features

- Single and dual outlet models - two high-flow models available
- Inlet has perforated holes on three sides; rain shrouds available if required
- Filters have urethane end caps with radial seal sealing technology
- Built-in pre-cleaning tubes separate up to 97% of the in-coming dust
- Latch-style cover with attached safety chain for faster and simpler filter service
- Constructed of heavy-gauge steel with a primed, ready-to-paint finish
- Same overall package size as older Donaldson SRG axial seal style housings
- Drop down tube accessory available simplifies routine air cleaner inspections
- Indicator thread size = 1/8-27NPT (MALE)

Filter Features

- Replacement main filter choices: Standard life filters (for scheduled maintenance) and Donaldson Endurance™ extended service high efficiency filters. Air cleaners ship with the standard filters.
- Grab handles on the main filter to help remove the loaded filter during service
- Safety filter on all models



The large, massive mining vehicle in the picture above is an ideal match for the Donaldson SSG Air Cleaner.

Powerful Two-Stage Filtration

The first stage of this powerful air cleaner consists of hundreds of Donaclone™ pre-cleaner tubes (over 130 tubes in the SSG 20 and over 25 tubes in the SSG 29 models). Each tube spins the incoming air to create a centrifugal force that separates up to 97% of the dust and dirt in the airstream (see image on right). Donaclone™ tubes have no moving parts – so there is nothing to break down or maintain. They function properly whenever the engine is running.

The pre-cleaned dust is automatically ejected from the dust cup with a Vacuator™ Valve located below in the lower housing body, below the Donaclone tubes.

The second stage of filtration is the primary filter. A safety filter, which fits inside the primary filter, is standard on all models for protection during primary filter changeout.



Side view of three Donaclone pre-cleaning tubes.

SSG Specifications

Heavy Dust Conditions

Front View Dual Outlet

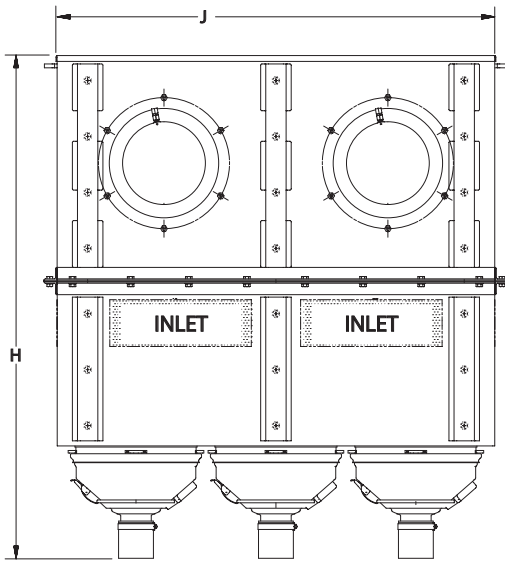

Front View Single Outlet

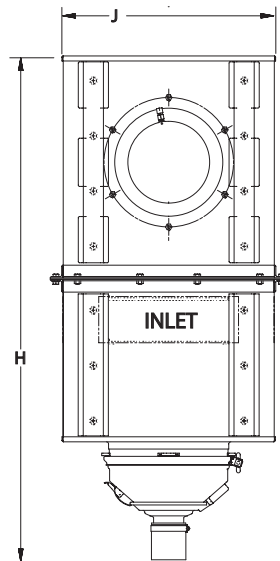

Side View Dual and Single

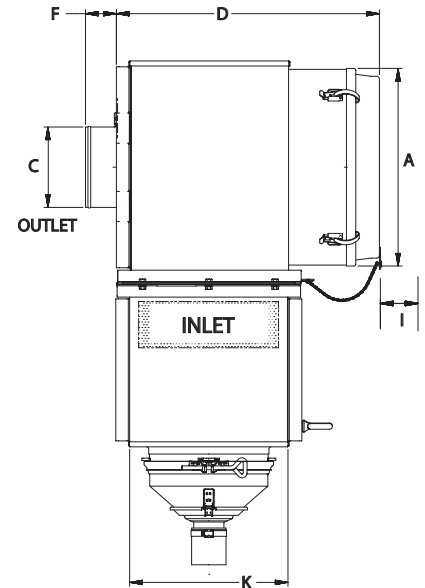

| Air Cleaner Model No. | Airflow m ³ /min. | Range Dimensions (mm) | | | | | | | |
|-----------------------------|---------------------------------|-----------------------|-----|-----|----|------|-----|------|-----|
| | | A | C | D | F | H | I | J | K |
| Single Outlet Models | | | | | | | | | |
| G200087 | 48 - 56 | 500 | 203 | 665 | 76 | 1274 | 559 | 533 | 400 |
| G200086 | 50 - 58 | 500 | 254 | 665 | 76 | 1274 | 559 | 533 | 400 |
| G200088* | 59 - 68 | 500 | 254 | 798 | 76 | 1274 | 686 | 533 | 597 |
| Dual Outlet Models | | | | | | | | | |
| G290057 | 73 - 85 | 500 | 203 | 665 | 76 | 1255 | 559 | 1092 | 400 |
| G290052 | 95 - 108 | 500 | 203 | 665 | 76 | 1255 | 559 | 1092 | 400 |
| G290053 | 102 - 116 | 500 | 254 | 665 | 76 | 1255 | 559 | 1092 | 400 |
| G290055* | 119 - 135 | 500 | 254 | 798 | 76 | 1255 | 686 | 1092 | 597 |

* Sized to accommodate higher airflow

**Single Outlet Model - SSG 20
Service Parts**

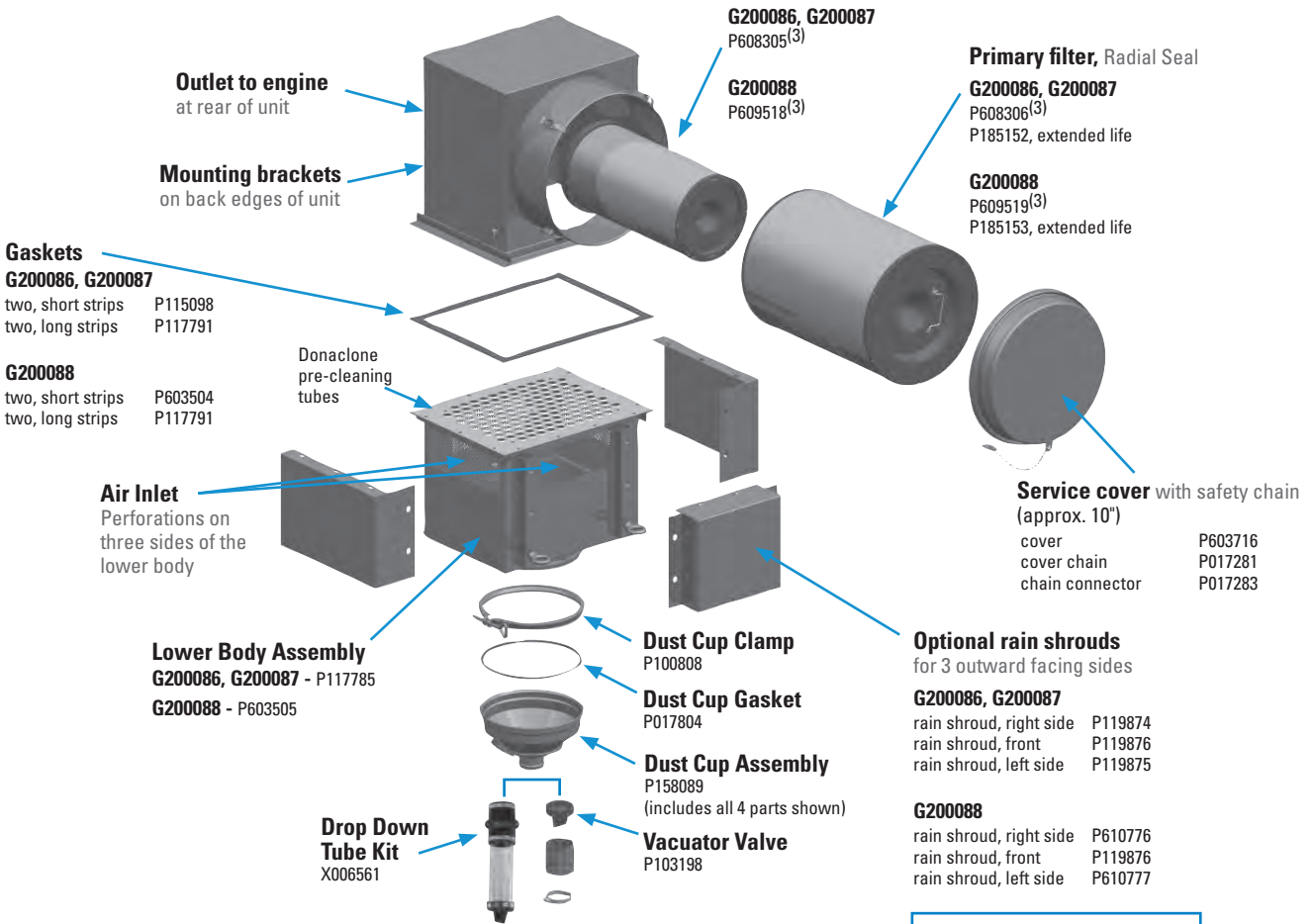

NOTES:
3 = Shipped with air cleaner initially

Drop Down Tube Extension

How it works: When installed on the dust cups on the lower assembly, the rubber connector vibrates during normal vehicle operation and gravity expels the pre-cleaned dust.

- Improves dust evacuation from the air cleaner
- Clear tube allows for visual inspection of dust collection
- Reduces air cleaner inspection time
- Ships fully assembled
- Proper conversion requires drop down tube for every dust cup

For more information features and dimensions, see the Accessories Section.



Part No. X006561

Heavy Dust Conditions

Dual Outlet Model - SSG 29 Service Parts

Heavy Dust Conditions

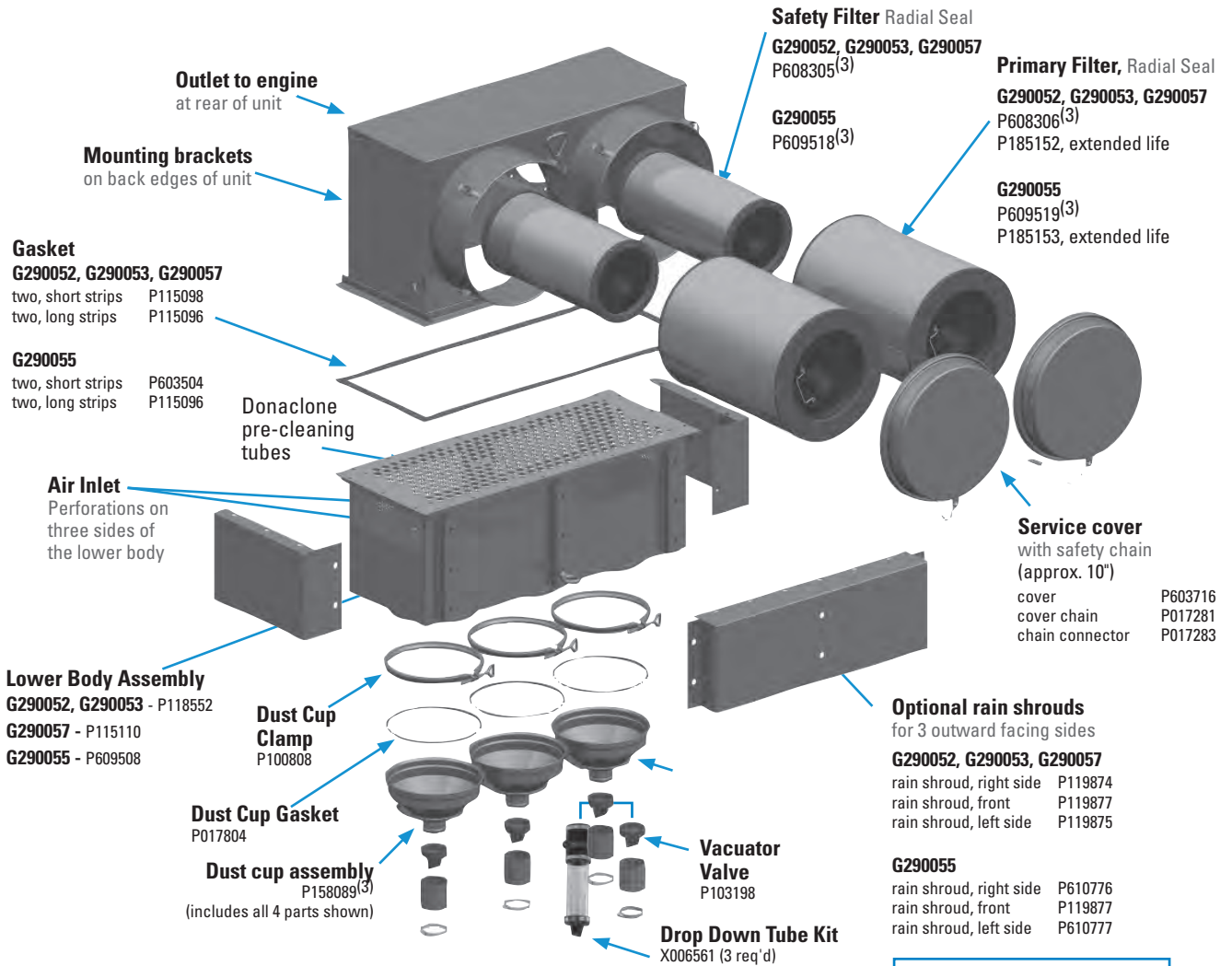

NOTES:
3 = Shipped with air cleaner initially

Drop Down Tube Extension

How it works: When installed on the dust cups on the lower assembly, the rubber connector vibrates during normal vehicle operation and gravity expels the pre-cleaned dust.

- Improves dust evacuation from the air cleaner
- Clear tube allows for visual inspection of dust collection
- Reduces air cleaner inspection time
- Ships fully assembled
- Proper conversion requires drop down tube for every dust cup

For more information features and dimensions, see the Accessories Section.



Part No. X006561

When specifying an Air Cleaner...

Determine the Airflow Requirements of your engine, then find the corresponding m³/min. airflow in the charts below. The restriction numbers - shown in mbar - indicate the approximate initial restriction of each model air cleaner at that m³/min. If there are two air cleaner models that fit your parameters, choosing the one with the lowest restriction will provide the longest service life. When calculating total initial restriction of the entire air intake system, include the restriction caused by ducting, elbows, pre-cleaners, etc.

SSG Performance Curves

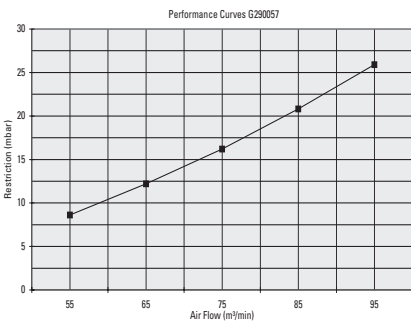
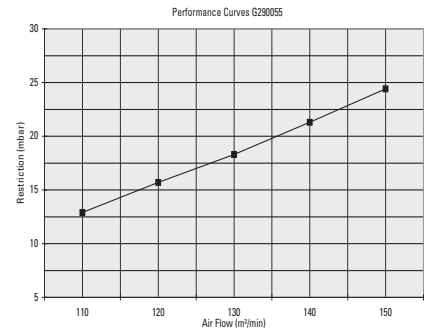
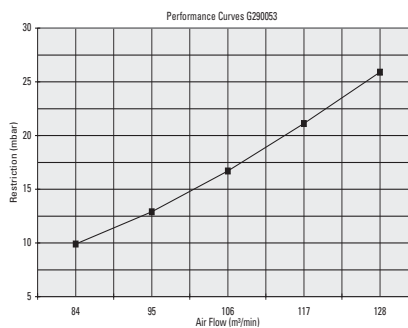
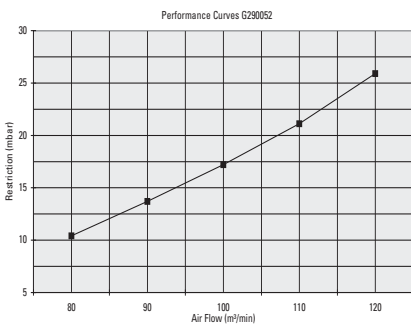
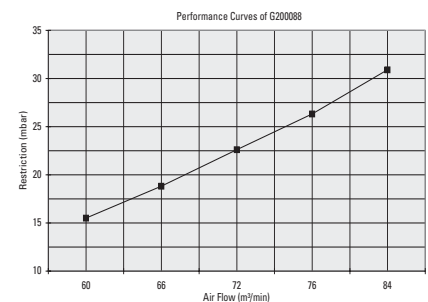
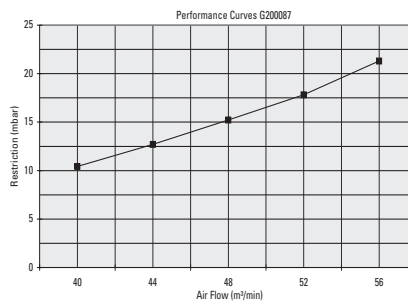
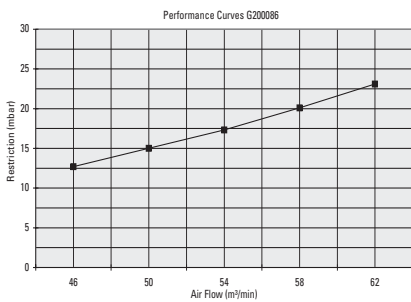

—■— Restr. A/c Piezo

All performance curves are according ISO 5011 standards - Restriction measured at Piezo
 All tests are done with ISO Coarse at Dust Concentration of 1g/m³

SSG Donaclone™ Service Instructions



1 Measure Restriction

Measure the restriction of the air cleaner with a Donaldson filter service indicator, service gauge, or a water manometer via the restriction tap provided on the air cleaner or the transfer pipe. Replace the filter only when the restriction level has reached the maximum recommended by the engine or equipment manufacturer.



2 Check Vacuator™ Valve

On dust cups with Vacuator Valve, dust cup service is minimal; just check the Vacuator Valve to see that it is not inverted, damaged or plugged. If it is damaged, replace it immediately.



3 Check Tubes for Plugging

When the dust cup is removed, check the tubes. Generally, Donaclone tubes are self-cleaning and need no service. Under rare circumstances, however, plugging can occur. Visual inspection is adequate. If the tubes carry light dust, remove it with a stiff brush.

Cleaning Note: Never clean Donaclone tubes with compressed air unless both the primary and safety filters are installed in the air cleaner. Do not steam-clean Donaclone tubes.

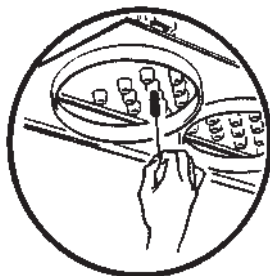

4 Change the Filter

When restriction indicates that filter service is required, unfasten or unlatch the service cover. Because the filter fits tightly over the outlet tube to create the critical seal, there will be some initial resistance, similar to breaking the seal on a jar. Grasp the filter service handle and pull the filter out, gently moving the filter back and forth to break the seal.



Avoid knocking the filter against the housing during removal. If the new filter is not to be installed immediately, be sure to cover the seal tube with a cloth or the housing cover so that dirt is not ingested.

5 Inspect the New Filter before Installing

Inspect the new filter carefully, paying attention to the inside of the open end, which is the sealing area. NEVER install a damaged filter. A new Donaldson radial seal filter may have a dry lubricant on the seal to aid installation.

6 Insert New Radial Seal Filter Properly

If you are servicing the safety filter, this should be seated into position before installing the primary filter.

Insert the new filter carefully by hand, making certain it is completely seated into the air cleaner housing before securing the cover in place.



The critical sealing area will compress slightly, adjust itself and distribute the sealing pressure evenly. To complete a tight seal, apply pressure by hand at the outer rim of the filter, not the flexible center. (Avoid pushing on the center of the end cap.) No cover pressure is required to hold the seal. NEVER use the service cover to push the filter into place! Using the cover to push the filter in could cause damage to the housing or cover fasteners and will void the warranty.

If the service cover contacts the filter before it is fully in place, remove the cover and push the filter (by hand) further into the air cleaner and try again. The cover should go on with no extra force.

Once the filter is in place, secure the service cover.



NEVER use the service cover to push the filter into place! Using the cover to push the filter in could cause damage to the housing, cover fasteners and will void the warranty.

STG Donaclone: Field Proven and Reliable Heavy-Duty Workhorse for Construction & Off-Highway Applications

That Donaldson's STG Donaclone™ is arguably the most commonly used air cleaner, on the widest variety of heavy-duty equipment in the world, is a testament to its reliability and durability. With its two-stage air cleaning, heavy-duty construction, and variety of configurations, the STG works well in many heavy-duty applications like scrapers, crawlers, dumpers and haul trucks.

Powerful Two-Stage Filtration

The first stage of this powerful air cleaner consists of a cluster of Donaclone™ tubes. They spin the incoming air to create a centrifugal force that separates up to 95% of the dust and dirt in the airstream. Donaclone™ tubes have no moving parts – so there is nothing to break down or maintain. They function properly whenever the engine is running.

This pre-cleaned dust is collected in a dust cup on the bottom of the air cleaner housing.

The second stage of filtration is the primary filter, a cylindrical-shaped unit of specially-developed pleated filter media, designed to trap and stop dust particles, both large and small. The result is air to your engine that is up to 99.9% contaminant free!



This STG Donaclone, mounted on a large mining machine, is protecting the engine from harmful dirt in this severely dusty environment.

A safety filter, which fits inside the primary filter, is standard on all models for protection during primary filter changeout. Physical orientation does not affect the proper functioning of either cleaning stage!

The STG operates well mounted horizontally or vertically. (Note that if mounting horizontally, the Vacuator™ Valve option on the dust cup is necessary.)

Mounting: Sturdy mounting brackets are attached to the top section of the STG; you will also need to order one separate mounting band for the lower body.

If you're replacing a worn out air cleaner, be sure to check ductwork, clamps, and other intake system parts that may also need replacing.

STG air cleaners feature a corrosion-resistant, chemical-resistant polymer coating. This black coating isn't paint, rather it's a pigmented polyester that provides a long-lived, hard protective finish.

Versatile STG Provides Airflow to 50 m³/min. Choose Peripheral or Tubular Inlet, Horizontal or Vertical Mount

Applications

- Allows 11 to 50 m³/min. airflow throughput per air cleaner
- Horizontal or vertical installation
- Off-road, high dust conditions

Air Cleaner Features

- Very reliable!
Only one critical filter seal!
- Airflow throughput can be doubled by using two air cleaners
- Two body styles (peripheral inlet and tubular inlet) to accommodate location and ducting
- Optional inlet shroud available for peripheral style
- When the air cleaner is mounted directly on the engine and there is clearance around it for airflow, choose the peripheral inlet style (see photo on right)
- When the air cleaner is mounted above the cab or somewhere far from the engine to get above the dust cloud, choose the tubular inlet style, which will accept ducting into the inlet
- Built-in Donaclone pre-cleaning tubes separate up to 95% of incoming dust to dust cup before it reaches the filter, resulting in more thorough cleaning and fewer filter changes!
- Choose the dust cup best suited to your maintenance practices: (1) the quick-release style for easy, manual emptying, or (2) a dust cup with a Donaldson Vacuator Valve that expels the dust automatically
- All models include a fitting for a filter service indicator

Filter Features

- Replacement main filter choices: Standard life filters (for scheduled maintenance) and Donaldson Endurance extended service high efficiency filters
- Safety filter on all models

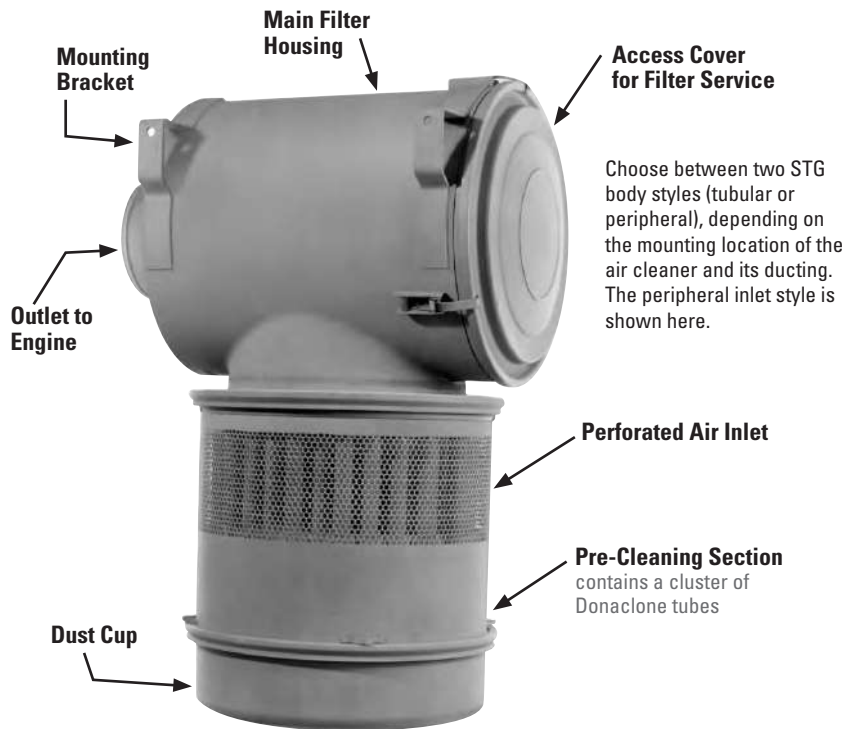

How the Two-Stage STG Donaclone Works

Air is drawn in through the perforations in the lower part of the unit and forced down through a bank of Donaclone tubes.

The Donaclone tubes spin the air so that centrifugal force causes the heavier dust particles to separate from the airstream.

While these particles fall into the dust cup at the bottom, the partially cleaned air is directed upward, into the primary filter in the upper portion of the unit.

The specially-developed pleated media in the primary filter stops up to 99.9% of the remaining dust, allowing clean air to pass to the engine.

STG Specifications

With Peripheral Inlet

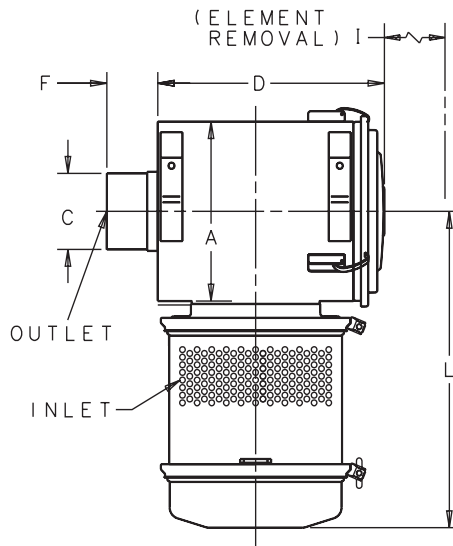

With Tubular Inlet

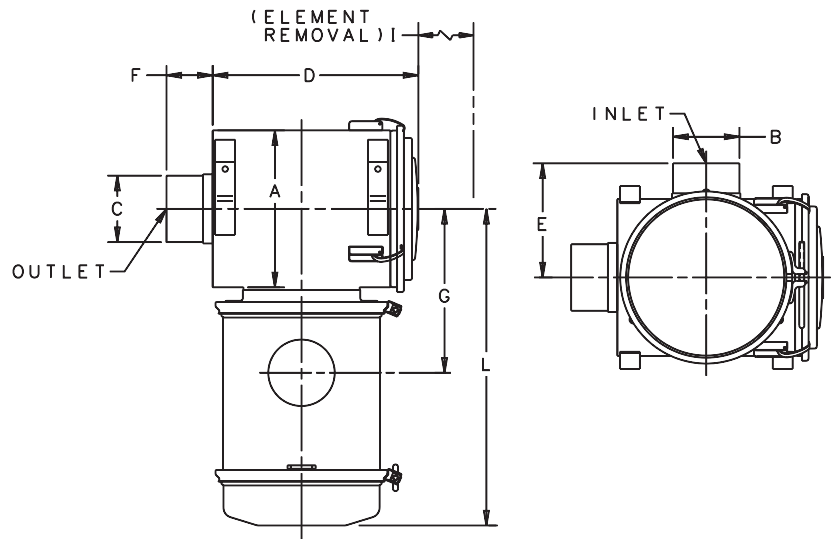

Heavy Dust Conditions

| Air Cleaner Model No. | Airflow Range m ³ /min. | | | Dimensions (mm) | | | | | | | | |
|------------------------|------------------------------------|-------------------------|-------------------------|-----------------|-----|-----|-----|-----|-----|-----|-----|-----|
| | 150 mm H ₂ O | 200 mm H ₂ O | 255 mm H ₂ O | A | B | C | D | E | F | G | I | L |
| | STG with Peripheral Inlet | | | | | | | | | | | |
| G140076 | 20 | 24 | 27 | 356 | - | 152 | 441 | - | 99 | 393 | 387 | 614 |
| G160077 | 29 | 33 | 37 | 406 | - | 178 | 500 | - | 99 | 439 | 432 | 664 |
| G161006 | 38,5 | 44,5 | 50 | 406 | - | 203 | 662 | - | 89 | 439 | 594 | 684 |
| STG with Tubular Inlet | | | | | | | | | | | | |
| G120332 | 11 | 13 | 15 | 300 | 127 | 127 | 392 | 200 | 100 | 293 | 335 | 560 |
| G140445 | 17 | 19 | 22 | 356 | 152 | 152 | 441 | 254 | 99 | 334 | 387 | 614 |
| G160445 | 26 | 30 | 34 | 406 | 178 | 178 | 498 | 279 | 98 | 376 | 438 | 668 |
| G161020* | 32 | 37 | 41,5 | 406 | 152 | 203 | 662 | 255 | 89 | 257 | 594 | 668 |

* G161020 has two inlets, each 152 mm in diameter.
 Note: All STG models are tapped to accept a filter service indicator.

STG Donaclone™ with Peripheral Inlet - Service Parts

G140076

| | |
|--------------------------------|---------|
| body, lower..... | P102256 |
| clamp, cup..... | P100866 |
| cover latch assembly..... | P017617 |
| dust cup..... | P100860 |
| filter, primary - SM..... | P181041 |
| filter, primary - ES & HE..... | P185041 |
| filter, primary..... | P182041 |
| filter, safety..... | P119370 |
| gasket, body or cup..... | P017335 |
| gasket, cover..... | P016972 |
| gasket kit..... | X003538 |
| gasket washer..... | P105740 |
| inlet shroud (optional)..... | P102870 |
| mounting band..... | H000350 |
| safety signal indicator..... | X004816 |
| spring clip & pin..... | X005555 |
| wing nut..... | P109062 |

G160077

| | |
|--------------------------------|---------|
| body, lower..... | P115023 |
| clamp, body..... | P100780 |
| clamp, cup..... | P100789 |
| cover..... | P109153 |
| cover latch assembly..... | P017617 |
| dust cup..... | P100794 |
| dust cup, quick release..... | P107377 |
| dust cup, vac valve, horz..... | P103530 |
| dust cup, vac valve, vert..... | P104973 |
| filter, primary - SM..... | P181039 |
| filter, primary - ES & HE..... | P185039 |
| filter, primary..... | P182039 |
| filter, safety..... | P114931 |
| gasket, body or cup..... | P017336 |
| gasket, cover..... | P017367 |
| gasket kit..... | X003539 |
| gasket washer..... | P105740 |
| inlet shroud (optional)..... | P101759 |
| mounting band..... | H000351 |
| safety signal indicator..... | X004816 |
| spring clip & pin..... | X005555 |
| wing nut..... | P109062 |

G161006

| | |
|--------------------------------|---------|
| clamp, body..... | P100780 |
| clamp, cup..... | P100789 |
| dust cup..... | P100794 |
| dust cup, quick release..... | P107377 |
| dust cup, vac valve, horz..... | P103530 |
| dust cup, vac valve, vert..... | P104973 |
| filter, primary - SM..... | P181042 |
| filter, primary - ES & HE..... | P185042 |
| filter, primary..... | P182042 |
| filter, safety..... | P128408 |
| gasket, body or cup..... | P017336 |
| gasket, cover..... | P017367 |
| gasket kit..... | X003539 |
| gasket washer..... | P105740 |
| inlet shroud (optional)..... | P101759 |
| mounting band..... | H000351 |
| safety signal indicator..... | X004816 |
| wing nut..... | P109062 |

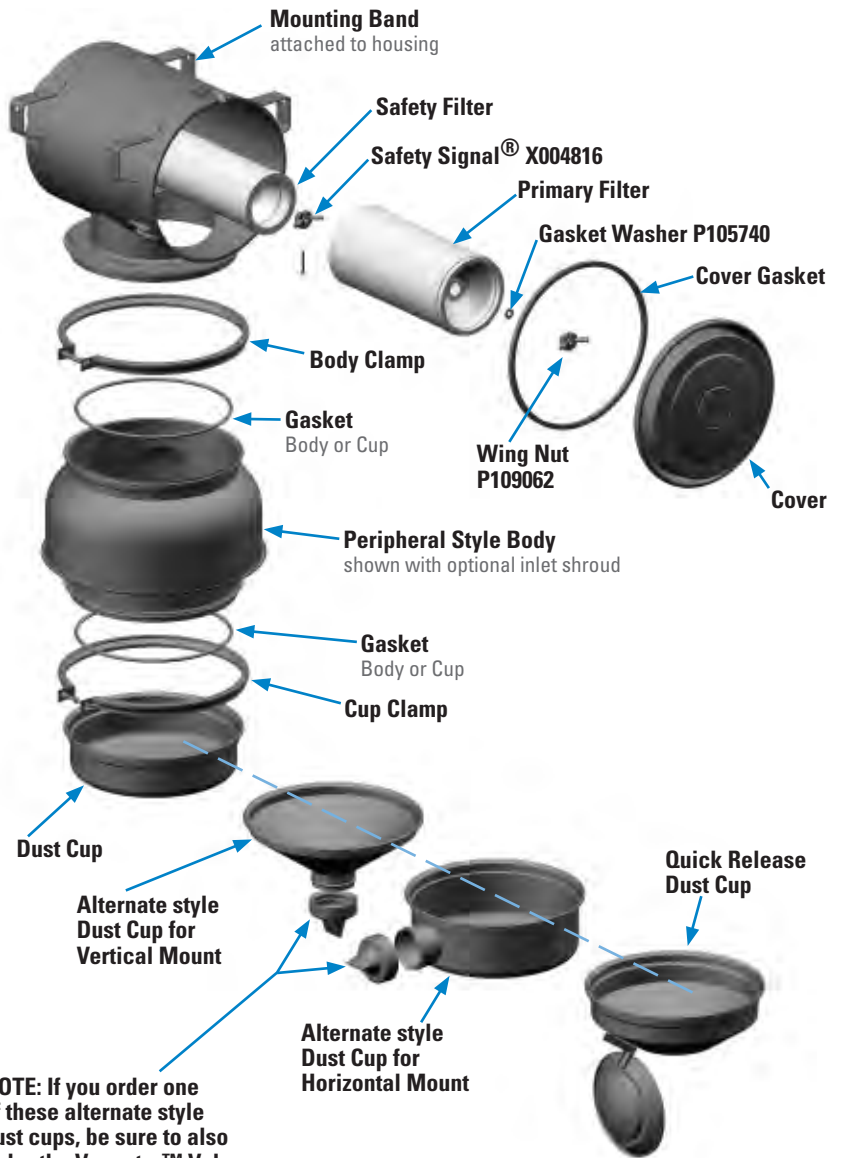

NOTE: If you order one of these alternate style dust cups, be sure to also order the Vacuator™ Valve P112803

NOTES:
 2 = Two required for proper installation
 3 = Shipped with air cleaner initially
 9 = Gasket Kit includes all gaskets listed

ES = Extended Service
 HE = High Efficiency
 SM = Scheduled Maintenance

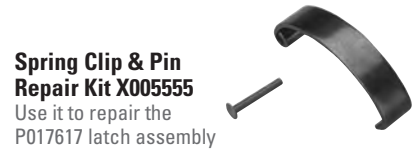

STG Donaclone™ with Tubular Inlet - Service Parts

G120332

| | |
|--------------------------------|---------------|
| body, lower..... | P110875 |
| dust cup, quick release | P107375 |
| filter, primary - SM | P181044 |
| filter, primary - ES & HE..... | P185044 |
| filter, primary..... | P1820443 |
| filter, safety | P119371 |
| gasket, body or cup | P017804 |
| gasket, cover..... | P017365 |
| gasket washer..... | P105740 |
| mounting band..... | H0003492 |
| safety signal indicator..... | X004816 |
| spring clip & pin | X005555 |
| wing nut | |

G140445

| | |
|---------------------------------|---------------|
| air inlet hood..... | H000606 |
| lower body..... | P114100 |
| cover latch assembly | P017617 |
| dust cup..... | P1008603 |
| dust cup, quick release | P107377 |
| dust cup, vac valve, horz | P103746 |
| dust cup, vac valve, vert | P105016 |
| filter, primary - SM | P181041 |
| filter, primary - ES & HE..... | P185041 |
| filter, primary..... | P1820413 |
| filter, safety | P119370 |
| gasket, body or cup | P017335 |
| gasket, cover | P016972 |
| gasket kit | X0035389 |
| gasket washer..... | P105740 |
| mounting band..... | H0003502 |
| safety signal indicator..... | X004816 |
| spring clip & pin | X005555 |
| wing nut..... | P109062 |

G160445

| | |
|---------------------------------|---------------|
| cover | P109153 |
| cover latch assembly | P017617 |
| dust cup..... | P1007943 |
| dust cup, quick release | P107377 |
| dust cup, vac valve, horz | P103530 |
| dust cup, vac valve, vert | P104973 |
| filter, primary - SM | P181039 |
| filter, primary - ES & HE..... | P185039 |
| filter, primary..... | P1820393 |
| filter, safety | P114931 |
| gasket, body or cup | P017336 |
| gasket, cover | P017367 |
| gasket kit | X0035399 |
| gasket washer..... | P105740 |
| mounting band..... | H0003512 |
| safety signal indicator..... | X004816 |
| spring clip & pin | X005555 |
| wing nut..... | P109062 |

G161020

| | |
|---------------------------------|---------------|
| dust cup..... | P1007943 |
| dust cup, quick release | P107377 |
| dust cup, vac valve, horz | P103530 |
| dust cup, vac valve, vert | P104973 |
| filter, primary - SM | P181042 |
| filter, primary - ES & HE..... | P185042 |
| filter, primary..... | P1820423 |
| filter, safety | P128408 |
| gasket, body or cup | P017336 |
| gasket, cover | P017367 |
| gasket kit | X0035399 |
| gasket washer..... | P105740 |
| mounting band..... | H0003512 |
| safety signal indicator..... | X004816 |
| wing nut..... | P109062 |

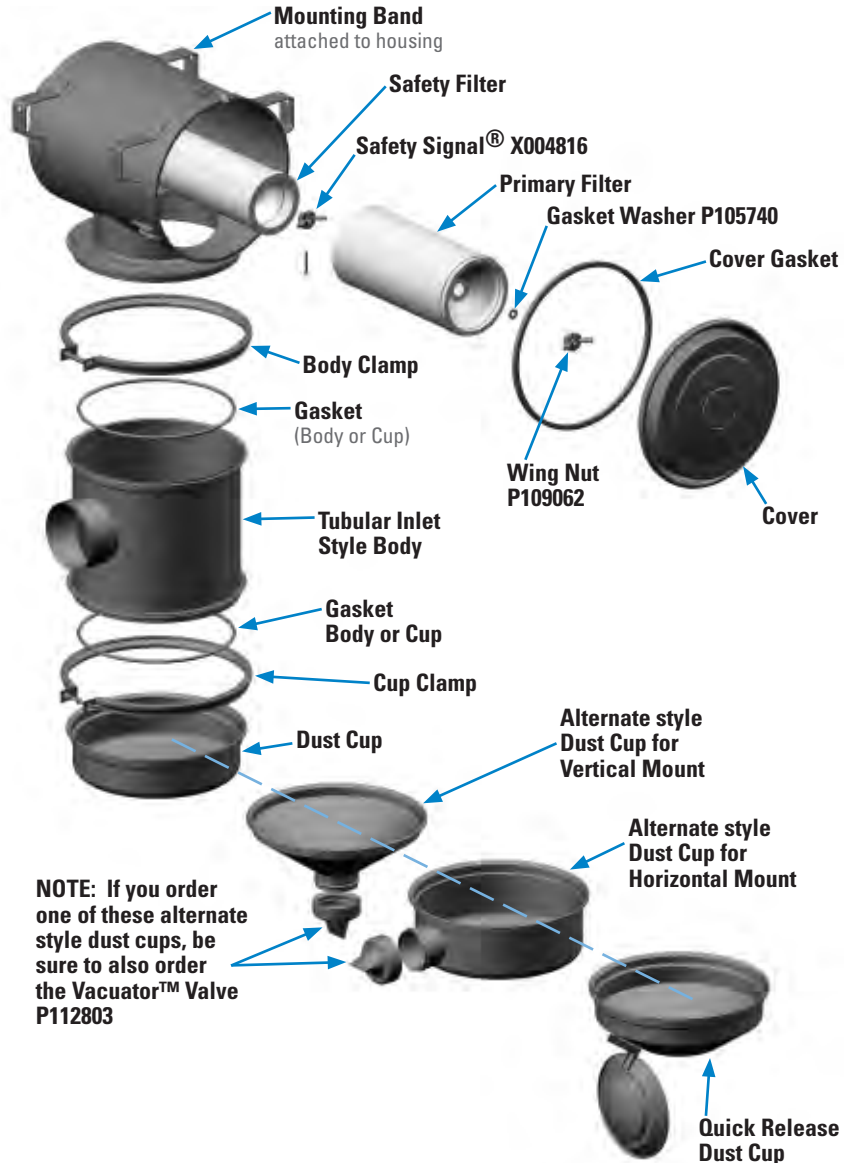

NOTES:
 2 = Two required for proper installation
 3 = Shipped with air cleaner initially
 9 = Gasket Kit includes all gaskets listed

ES = Extended Service
 HE = High Efficiency
 SM = Scheduled Maintenance

When specifying an Air Cleaner...

Determine the Airflow Requirements of your engine, then find the corresponding m³/min. airflow in the charts below. The restriction numbers - shown in mbar at the left side of the chart - indicate the approximate initial restriction of each model air cleaner at that m³/min. When calculating total initial restriction of the entire air intake system, include the restriction caused by ducting, elbows, pre-cleaners, etc. The estimated lab life hours are indicated at the right side of the chart.

STG Performance Curves

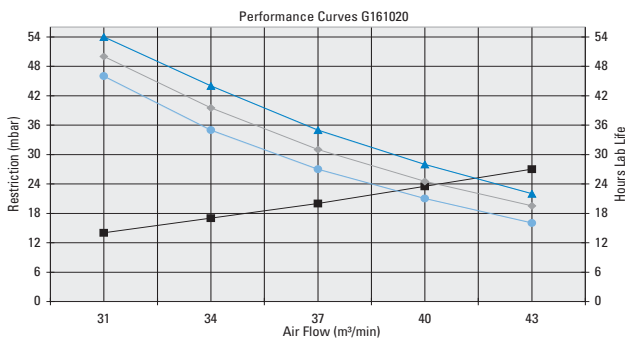
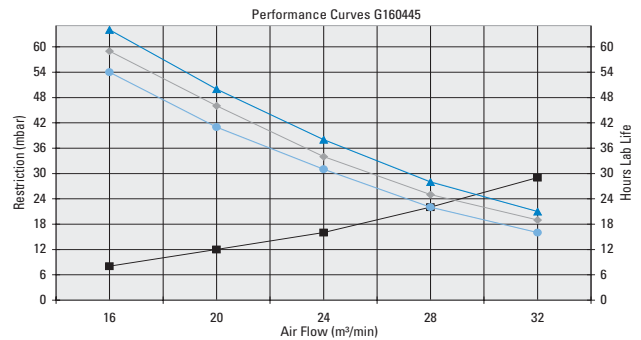
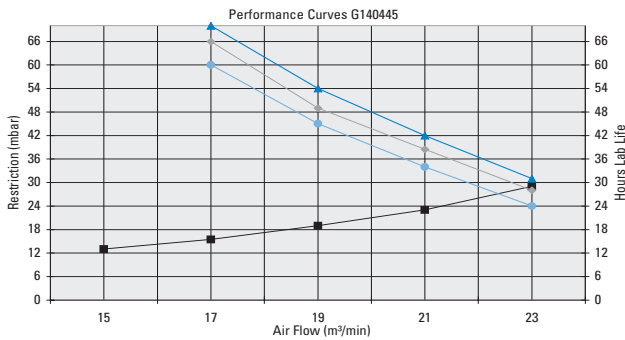
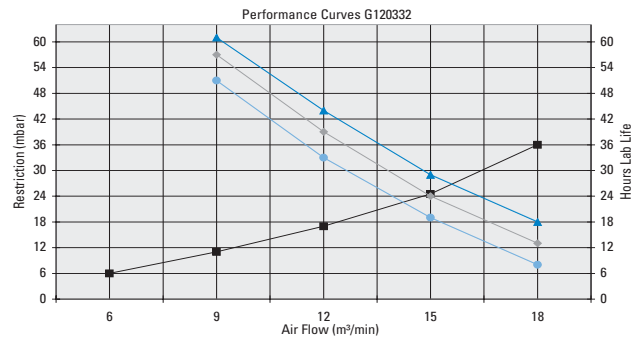
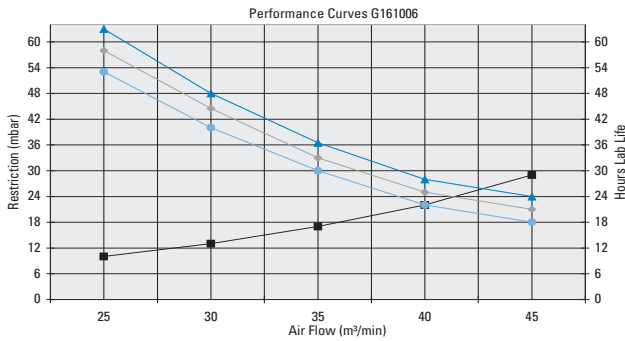
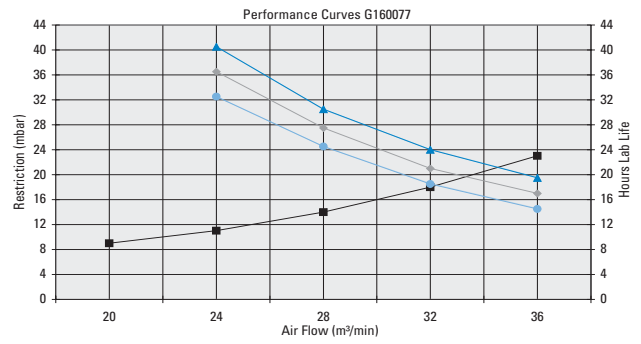
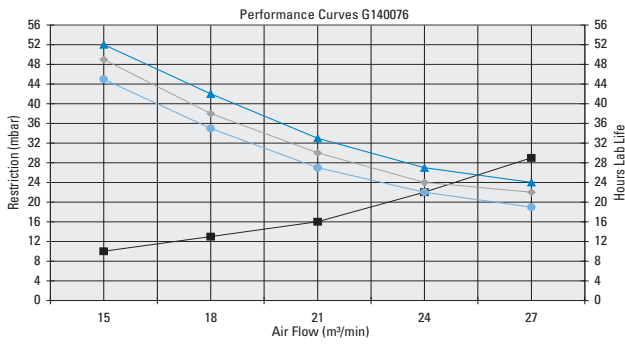

Restr. A/c Piezo
 LL50mbar
 LL62mbar
 LL75mbar

All performance curves are according ISO 5011 standards - Restriction measured at Piezo
 All tests are done with ISO Coarse at Dust Concentration of 1g/m³

1 Measure Restriction

Measure the restriction of the air cleaner with a Donaldson filter service indicator, service gauge, or a water manometer via the restriction tap provided on the air cleaner or the transfer pipe. Replace the filter only when the restriction level has reached the maximum recommended by the engine or equipment manufacturer.



2 Empty the Dust Cup

The dust cup should be dumped when 2/3 full. (Frequency of dust cup service varies with dust severity.) When reinstalling dust cup, be sure it

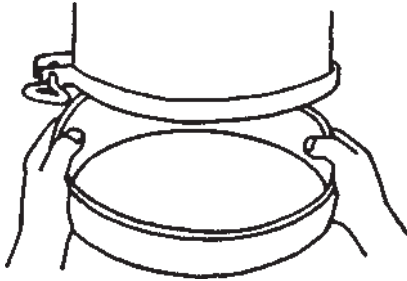

seals 360° around the air cleaner body. On dust cups with Vacuator™ Valve, dust cup service is minimal; just check the Vacuator™ Valve to see that it is not inverted, damaged or plugged. If it is damaged, replace it immediately.



Vacuator™ Valve

3 Check Tubes for Plugging

When the dust cup is removed, check the tubes. Generally, Donaclone™ and Strata™ tubes are self-cleaning and need no service. Under special circumstances, however, plugging can begin. Visual inspection is adequate. If the tubes carry light dust, remove it with a stiff brush. If heavy plugging with fibrous material is evident, remove the Strata™ or Donaclone™ section and clean it with compressed air or water no hotter than 72°C.

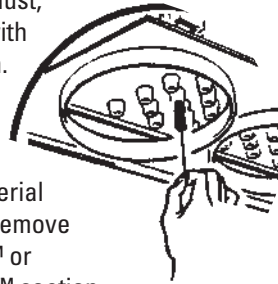

Cleaning Note: Never clean Donaclone™ tubes with compressed air unless both the primary and safety filters are installed in the air cleaner.

Do not steam-clean Donaclone™ or Strata™ tubes.

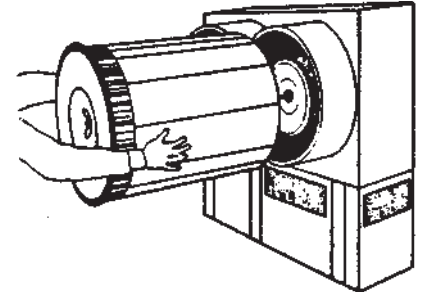

4 Change the Filter

When restriction indicates that filter service is required, loosen the wing nut and remove the primary filter. If the new filter is not to be installed immediately, be sure to cover the inlet with a cloth or the housing cover so that dirt is not ingested.

Before installing the new filter, inspect it for shipping damage and gasket integrity. If there is damage, DO NOT install it!

If the wing nut is held in place on the used filter with a C clip, remove it and reinstall on the new filter. Carefully install the new filter and the wing nut. Reset the filter service indicator to green.

5 Check System

Inspect and tighten all air cleaner system connections. If there are holes or damage, replace immediately. Inspect all gaskets for worn spots or damage. Annual replacement of air cleaner gaskets is recommended.

On-Line Product Info is More Current

Than Printed Materials!

While we know printed product information will not disappear anytime soon, more and more people are choosing to use our on-line literature informational tools as a product resource. Not only is it the most current information and it's available 24/7!

<http://www.emea.donaldson.com/en/engine/support/datalibrary/index.html>

The screenshot shows the Donaldson website's product literature section. The header includes the Donaldson logo and navigation links like 'Home', 'Engine & Vehicle', and 'Product Literature'. A search bar is present with the text 'Enter Search Term'. The main content area is titled 'Product Literature' and contains a paragraph explaining that product literature is available online and can be downloaded or ordered via email. Below this, there are several categorized lists of links, each preceded by a PDF icon. The categories include 'General' (with links for Toolbox Update Instructions, Engine Systems & Technologies, Working Together for a Cleaner World, and Tecnología & Sistemas de Motor), 'Warranty' (with links for Donaldson Engine AM Warranty in English, Italian, Russian, Spanish, Portuguese, French, and Dutch), 'Air Filtration' (with links for US Engine Air Cleaner Catalogue, Topspin™ Pre-Cleaner, Engine Air Filtration, Crankcase Ventilation - Spiracle, and PowerCore® G2 Filtration Technology (OE use)), 'Endurance™ Extended Service Filters' (with links for Cross Reference and Air Filters), and 'Liquid Filtration' (with links for Liquid Filtration, Fuel Filter Water Separators, and Syntec Media Technology for Fuel Filters). A sidebar on the left contains navigation links such as 'Product Overview', 'Air Filtration', 'Lube/Fuel/Coolant Filtration', 'Hydraulics Filtration', 'Extended Service', 'Where To Buy', 'Contact Us', 'Product Literature', 'Customer Support', 'Frequently Asked Questions', 'News', and 'Events'. A small advertisement on the right side of the page promotes the catalog with the text 'Search our Catalog With nearly 8,000 products, we've got you covered!' and a 'SEARCH OUR CATALOG' button.

Donaldson Air Intake Accessories

... help you solve problems and maintain your system

Section Index

| | |
|---|-----|
| Clamps, Worm-Drive Hose & T-Bolt | 120 |
| Clamps, SealClamps™ | 121 |
| Drop Down Tube Extension (Dust Dumpa) ... | 122 |
| Exhaust Ejectors | 124 |
| In-Line Check Valve | 126 |
| In-Line Separators | 127 |
| Moisture Skimmer & Eliminator | 128 |
| Mounting Bands, Metal | 129 |
| Pre-Cleaners, DonaSpin™ | 130 |
| Pre-Cleaners, Full-View | 131 |
| Pre-Cleaners, TopSpin™ | 132 |
| Rain Caps | 134 |
| Restriction Indicators | 135 |
| Rubber Elbows, Humps & Reducers | 137 |
| Silicone Charge Air Connectors | 140 |
| Vacuator™ Valves | 141 |

When you need to, use...

Mount or install an air cleaner:

- Mounting Bands

Solve air intake water problems:

- In-line Moisture Skimmer
- In-line Moisture Separator
- Stack Top Moisture Eliminator

Pre-clean or protect air inlet from debris:

- Rain Caps
- TopSpin™ Pre-Cleaner
- Full-View Pre-Cleaner
- Donaspin™ Pre-Cleaner
- In-line separator

Know when to service a filter:

- Restriction Indicators

Aspirate (or scavenge) an intake system:

- Donaspin™ Pre-Cleaner
- Exhaust Ejectors
- Ejector Check Valve

Improve dust evacuation from Vacuator™
Valves:

- Drop Down Tube Extension

Connect intake components:

- Rubber Elbows and Connectors
- Clamps
- Rubber and Silicone Hump/Reducers
- Charge Air Connectors

Worm-Drive Hose Clamps

- Versatile clamps for wide size range of hose connections.
- Made of strong, durable, noncorrosive stainless steel.
- Inside of clamp is lined so that hose doesn't bulge through clamp holes.
- Narrow band enables easy installation in confined areas.



| Lined Hose Clamps | |
|-------------------|---------|
| Part Number | Size mm |
| P532919 | 14-21 |
| P532920 | 17-24 |
| P532921 | 21-27 |
| P532923 | 21-38 |
| P532924 | 21-44 |
| P532922 | 29-32 |
| P115200 | 40-62 |
| P115201 | 52-76 |
| P143422 | 71-95 |
| P115202 | 84-108 |
| P115203 | 109-133 |

Recommended application up to 4.6 Nm torque

Donaldson lined hose clamps seal silicone and other soft hoses without damage. The inner liner extends under the perforations to protect the hose and prevents extrusions through the worm-gear perforations.

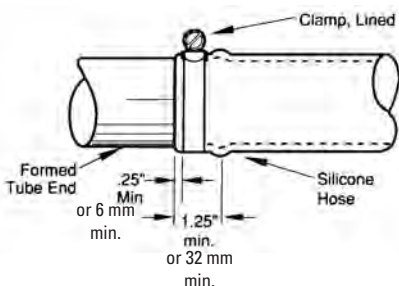

Initial torque on lined hose clamp should be 4.6 Nm. If retorquing is required, limit to 2.3 Nm.



| Constant Torque Clamps | |
|------------------------|---------|
| Part Number | Size mm |
| P532925 | 57-79 |
| P532926 | 70-92 |
| P532927 | 83-105 |
| P532928 | 95-117 |
| P532929 | 108-130 |

Recommended application up to 10.4 Nm torque

Donaldson Constant Torque lined clamps are the best choice for systems where clamps cannot be retightened and have difficult access. Perfect for applications requiring higher torque, large diameters, temperature extremes, or where expansions and contractions within the system are common. This clamp is a good choice for critical coolant and charge-air connections.



| High Torque Clamps | |
|--------------------|---------|
| Part Number | Size mm |
| P788708 | 83-105 |
| P115204 | 108-130 |
| P115205 | 133-156 |
| P115206 | 159-181 |
| P115207 | 184-206 |
| P115208 | 210-232 |
| P115209 | 260-286 |

Recommended application up to 17.3 Nm torque

This extra heavy-duty clamp ensures total protection against leakage.....eliminates the need for double clamping.

T-Bolt Clamps



| T-Bolt Clamps | | |
|---------------|--------------|---------|
| Part Number | Nominal I.D. | Size mm |
| P148337 | 51 | 57-64 |
| P148338 | 57 | 63-70 |
| P148339 | 64 | 71-78 |
| P148340 | 70 | 78-85 |
| P148341 | 76 | 84-91 |
| P148342 | 89 | 98-104 |
| P148343 | 102 | 109-116 |
| P148344 | 114 | 122-129 |
| P148345 | 127 | 135-142 |
| P148346 | 140 | 151-158 |
| P148347 | 152 | 162-169 |
| P148348 | 178 | 187-198 |
| P148349 | 203 | 216-226 |
| P148350 | 254 | 267-277 |

SealClamps™

Preformed & Flat Styles

Used to seal muffler inlets, outlets, elbow joints, flex pipes, and other system connections. Also minimizes noise and exhaust gas leaks.

SealClamps are easy to install! There's no need to weld or disconnect your exhaust system.

When installed, the wide band conforms to the shape of straight or flex pipe, and seals without distorting the pipe.

- For overlapping I.D. to O.D. slotted joints and flex tube.
- Nuts and bolts fit both 9/16" and 14mm wrenches.
- Reduces noise and exhaust leaks.
- Installs easily – no disconnecting or welding necessary.
- Available in aluminized and stainless steels.
- Stainless models have improved corrosion resistance and high temperature strength compared to aluminized.

- Full 360° preformed
- No flex pipe pinching
- Available in stainless and aluminized



Stepped Preformed SealClamp™

| Stepped Preformed SealClamps | | |
|------------------------------|------------|---------|
| Stainless | Aluminized | Pipe mm |
| X007829 | X007832 | 64 |
| X007830 | X007833 | 76 |
| X007831 | X007834 | 89 |
| X007784 | X007824 | 102 |
| X007785 | X007805 | 127 |

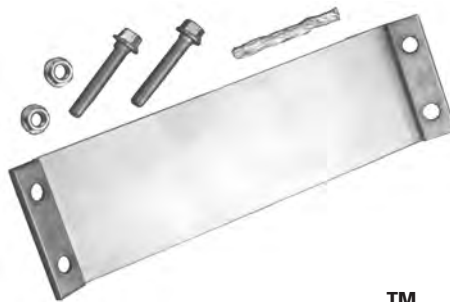

Flat Band SealClamp™

| Flat Band SealClamps | | |
|----------------------|------------|---------|
| Stainless | Aluminized | Pipe mm |
| X004536 | | 51 |
| X004537 | | 57 |
| X004476 | | 64 |
| X004538 | | 70 |
| X004478 | X005921 | 76 |
| X004480 | X006204 | 89 |
| X004482 | X006203 | 102 |
| X004962 | | 114 |
| X004484 | X006202 | 127 |
| X004539 | | 152 |



Preformed SealClamp™

| Preformed SealClamps | |
|----------------------|---------|
| Stainless | Pipe mm |
| X005265 | 64 |
| X005921 | 76 |
| X005164 | 89 |
| X007057 | 152 |

Drop Down Tube Extension (Dust Dumpa)

Replacement to Your Existing Dust Cup Assembly

Application

- Donaldson SSG Air Cleaners
- Donaldson PowerCore PSD Air Cleaners (10" and 12" models)

How It Works

When installed on the dust cups on the lower assembly, the rubber connector vibrates during normal vehicle operation and gravity expels the pre-cleaned dust.

Features

- Improves dust evacuation from the air cleaner
- Clear tube allows for visual inspection of dust collection
- Improves safety of the air cleaner inspection process by eliminating the need for ladders or elevated platforms for daily inspections
- Allows operators to perform walk around inspections
- Keeps operators and maintenance personnel away from the nuisance dust normally encountered during air cleaner servicing operations.
- Improves vehicle up time by minimizing pre/post –shift air cleaner inspections, thus facilitating increased air cleaner service intervals.
- Reduces air cleaner inspection time
- Ships fully assembled
- Proper conversion requires drop down tube for every dust cup



Part No.
X006562
(includes
dust cup
seal)



Part No.
X006561

Part No. X006562

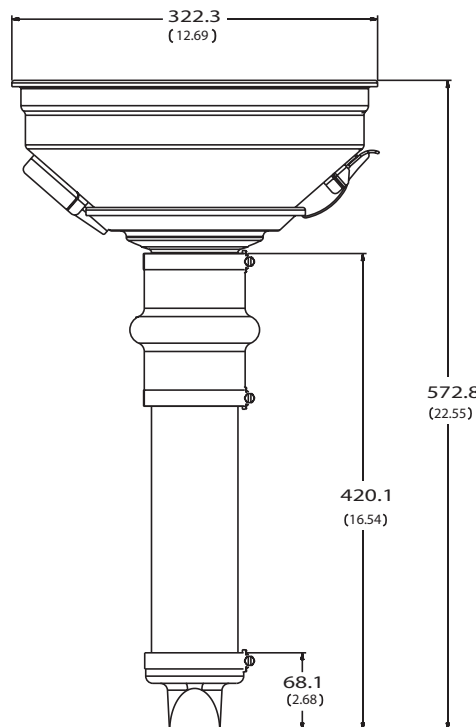

Part No. X006561

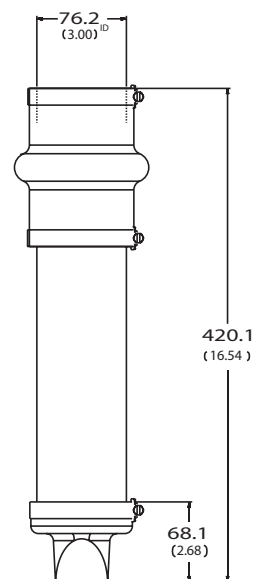

Drop Down Tube Extension (Dust Dumpa)

Available for SSG Air Cleaners

Existing S Series Air Cleaner Dust Cup Styles

Quick Release Dust Cup



Dust Cup - Original



Dust Cup - Newer Design



For Conversion Order
Kit X006562



For Conversion Order
Kit X006561



For Conversion Order
Kit X006561



Available for PowerCore® Air Cleaners (PSD08 - 09 - 10 & 12)



Also works on all other Air Cleaners with 76 mm drop tube

A Donaldson exhaust ejector removes dirt and debris from the air intake pre-cleaner through a scavenge hose that is routed out through the exhaust flow of your equipment.

It mounts as a stack at the end of exhaust system; stack caps or extension tubes may be added. There are three styles available – expanded, standard, compact – depending on the space and design of your equipment. Ejectors require no service and have no moving parts. A Donaldson T-Bolt Clamp, as show on page 120, is recommended for installation.

All ejectors are constructed of heavy-gauge, aluminised steel. Select the appropriate ejector by the intake airflow (m³/min.) of your engine.

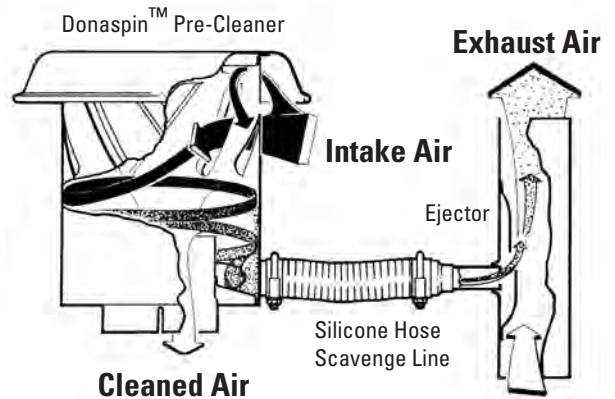

The Donaspin™ pre-cleaner uses a spinning motion of the airstream to force dirt and debris to the outside wall of the pre-cleaner body. The dirt and debris are forced to the bottom of the pre-cleaner and expelled by the secondary airflow developed by the ejector.



Expanded I.D. End Style

- Simplifies installation - requires less parts to install
- No need for separate connector!
- Fits over most standard muffler outlet tubes
- Adds only 1000 - 2000 Pa to exhaust backpressure

Standard Style

- Can be used with any pre-cleaner style
- Adds only 1000 - 2000 Pa to exhaust backpressure

Compact Style

- Used primarily on agricultural equipment
- Adds 2500 - 3800 Pa to exhaust backpressure

Expanded Inlet End Style Ejectors

| Part Number | Intake m ³ /min. | Inlet ID mm | Scavenge Tube ID mm | Length mm | Exhaust m ³ /min. | | 3-ply silicone scavenge hose* | Lined Hose clamp |
|-------------|-----------------------------|-------------|---------------------|-----------|------------------------------|-----|-------------------------------|------------------|
| | | | | | min | max | | |
| H002129 | 14 - 20 | 131 | 38 | 749 | 36 | 51 | P171378 | P115200 |
| H002132 | 29,5 - 42 | 157 | 51 | 826 | 74 | 105 | P171381 | P115200 |

Standard Style Ejectors

| Part Number | Intake m ³ /min. | Inlet ID mm | Scavenge Tube ID mm | Length mm | Exhaust m ³ /min. | | 3-ply silicone scavenge hose* | Lined Hose clamp |
|-------------|-----------------------------|-------------|---------------------|-----------|------------------------------|-----|-------------------------------|------------------|
| | | | | | min | max | | |
| H001032 | 7 - 10 | 77 | 38 | 445 | 18 | 25 | P171378 | P115200 |
| H001033 | 9 - 12,5 | 102 | 38 | 610 | 22 | 31 | P171378 | P115200 |
| H001034 | 11 - 15 | 102 | 38 | 610 | 27,5 | 39 | P171378 | P115200 |
| H001035 | 14 - 20 | 128 | 38 | 749 | 36 | 51 | P171378 | P115200 |
| H001039 | 36 - 51,5 | 153 | 51 | 826 | 92 | 130 | P171381 | P115200 |

Compact Style Ejectors

| Part Number | Intake m ³ /min. | Inlet ID mm | Scavenge Tube ID mm | Length mm | Exhaust m ³ /min. | | 3-ply silicone scavenge hose* | Lined Hose clamp |
|-------------|-----------------------------|-------------|---------------------|-----------|------------------------------|------|-------------------------------|------------------|
| | | | | | min | max | | |
| H001282* | 1 - 2 | 51 | 32 | 178 | 3 | 4 | P171376 | P532924 |
| H001277* | 2,5 - 3,5 | 57,5 | 32 | 202 | 6 | 9 | P171376 | P532924 |
| H001283* | 3 - 4,5 | 64 | 32 | 226 | 8 | 11 | P171376 | P532924 |
| H001278* | 5 - 6 | 70 | 32 | 248 | 12 | 15 | P171376 | P532924 |
| H001280* | 6 - 9,5 | 89 | 32 | 318 | 16 | 24 | P171376 | P532924 |
| H001279* | 8,5 - 11 | 77 | 32 | 274 | 21,5 | 28 | P171376 | P532924 |
| H001281* | 10,5 - 14 | 102 | 32 | 365 | 26,5 | 34 | P171376 | P532924 |
| H001284* | 13 - 17 | 102 | 32 | 365 | 32 | 42,5 | P171376 | P532924 |

* Do not use in fibrous environment, e.g. Combine Harvestors



Installation Instructions

- For proper function of the Valve the INDEX needs to be installed upwards
- Install inline check valve as close as possible to the air cleaner
- Temperature resistance of 200°C
- Different connection diameters: 32 - 38 - 50 mm

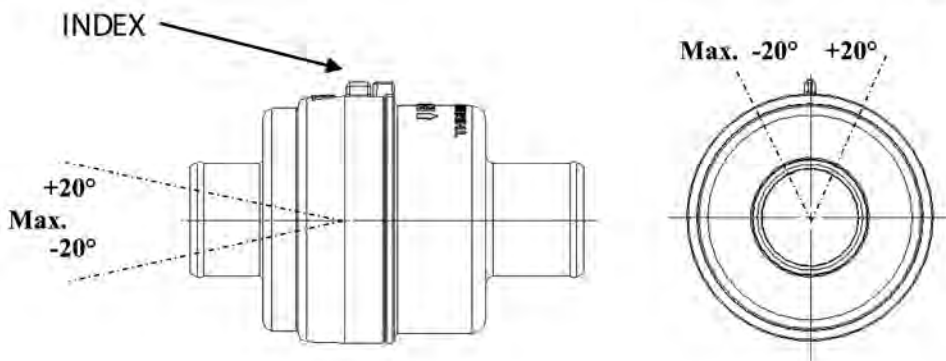

Scavenge Flow Direction

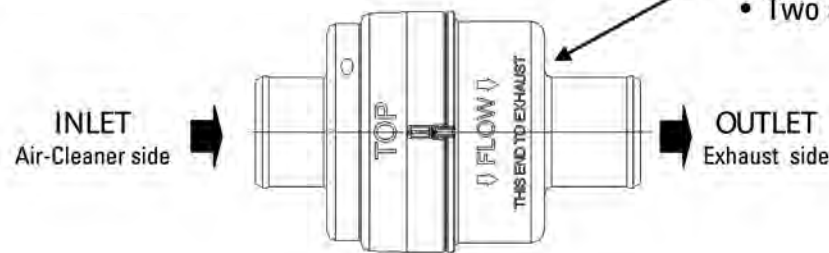

- Hose towards Exhaust system need to be fixed on this side
- Two arrows indicate airflow direction

| Check Valve Assy | Inlet Diameter | Outlet Diameter |
|------------------|----------------|-----------------|
| P786337 | 32 | 32 |
| P786339 | 50 | 32 |
| P786338 | 38 | 32 |
| P786341 | 32 | 38 |
| P786342 | 50 | 38 |
| P786340 | 38 | 38 |
| P786345 | 32 | 50 |
| P786343 | 50 | 50 |
| P786344 | 38 | 50 |

Two-stage Cleaning for Unexpected Dust/Moisture Conditions

When your truck is being used in heavier-than-anticipated dust or moisture conditions, you may not have to replace the entire air cleaner. The problem may be solved by adding a Donaldson In-Line Separator.

Installing this unit on your one-stage system creates a two-stage air filtration system. This enables an over-highway vehicle, which usually sees only light-dust, to be easily and economically adapted to off-road conditions, where medium- to heavy-dust is encountered.

Applications

Vertical model:

On/off road, mounted on inlet tubing or cowl mounted directly to air cleaner
 - Compatible with engine airflows of 14 to 43 m³/min.

Horizontal model:

On/off road, typically mounted under hood
 - Compatible with engine airflows of 3 to 40 m³/min.

Features

- 80% water removal efficiency
- 70% dust removal efficiency

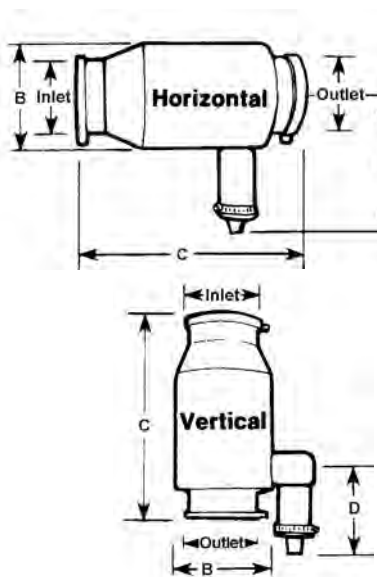

Horizontal model, for airflow of 3 to 40 m³/min.
 Mounts underhood.

Vertical model, for airflow of 14 to 43 m³/min.
 Mounts on stack top.



How It Works

- 1 When moisture - and/or dust-filled air - enters at one end, the built-in, stationary vanes cause the air to spin.
- 2 This spin creates centrifugal force, which pushes all moisture and dust to the outside wall where it separates from the air.
- 3 Moisture and dust are thrown into the Vacuator Valve tubing, then automatically released by the Vacuator Valve.
- 4 Clean air (acceptable for maximum filter life and engine performance) passes to the air cleaner.

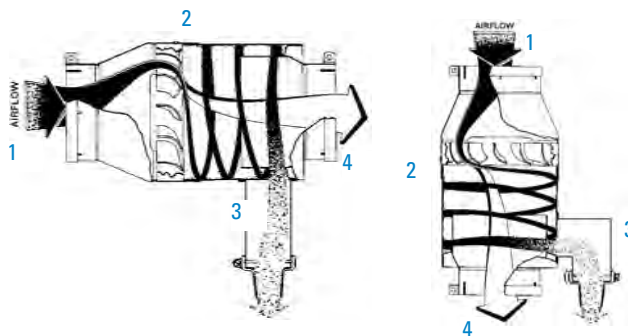

| Part Number | Airflow Range | Inlet mm | Diameter Outlet mm | Length (B) mm | (C) mm | (D) mm |
|-------------------------|---------------|------------|--------------------|---------------|--------|--------|
| Horizontal Style | | | | | | |
| H001474 (1) | 3 - 11 | 102 OD (2) | 102 OD | 140 | 292 | 182 |
| H000875 | 14 - 28 | 152 ID (3) | 152 ID | 217 | 438 | 294 |
| H001906 | 20 - 40 | 178 ID | 178 ID | 244 | 432 | 305 |
| Vertical Style | | | | | | |
| H000878 | 14 - 31 | 152 ID | 152 ID | 217 | 438 | 198 |
| H000886 | 21 - 31 | 178 ID | 178 ID | 217 | 438 | 198 |
| H001220 | 26 - 43 | 203 OD | 203 OD | 244 | 432 | 116 |

(1) Lightweight aluminium construction (2) OD = Outer Diameter (3) ID = Inner Diameter

Horizontal, In Line Moisture Skimmer Removes Water

Applications

- Allows 17 to 34 m³/min. airflow.
- Horizontal mount in engine air intake ducting.

Features

- Removes over 80% of water before it can reach and damage the filter.
- No service needed!
- Made of durable rubber.
- Collected water is automatically released by Vacuator™ Valve.
- Adds little or no restriction to airflow.
- Common inlet sizes fit most installations.



Mounting Position

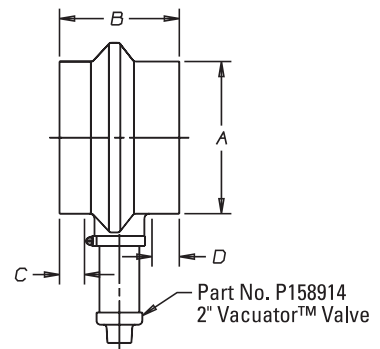
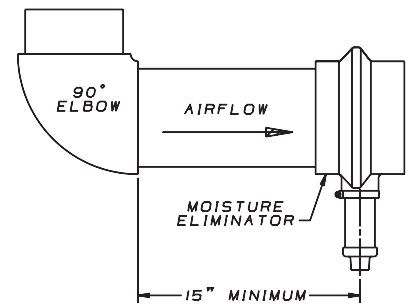

| Part Number | Flow m ³ /min | Inner Dia. (A) mm | Length (B) mm | Tube (C) mm | Stops (D) mm |
|-------------|--------------------------|-------------------|---------------|-------------|--------------|
| X005822 | 17-28 | 152 | 152 | 32 | 35 |
| X005900 | 23 | 178 | 152 | 32 | 35 |
| X005901* | 23 | 178 | 152 | 32 | 35 |

* Angled Spout

Stack-Top Moisture Eliminator Prevents Water Provers

- For cabover trucks, on/off road, mounted on top of 7" (178mm) O.D. intake stack.
- For airflow range of 17 to 34 m³/min.
- Over 80% water removal efficiency.
- Includes clamp for installation.

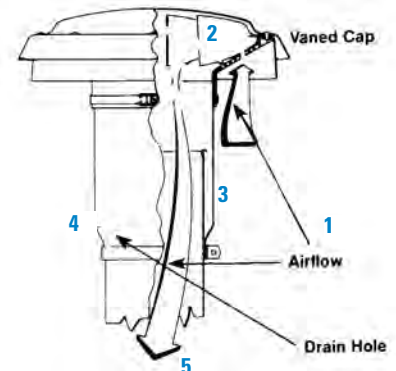

How They Work

- (1) Moisture-filled air enters the moisture eliminator cap.
- (2) Built-in, stationary vanes cause the air to spin.
- (3) Moisture is forced to the outside wall, where it separates from the air and collects.
- (4) Water drains out through the drain hole.
- (5) As a result, drier air (acceptable for maximum filter life and engine performance) passes to the air cleaner.

Many sizes Designed to Fit all Donaldson Air Cleaners

- Durable, corrosion resistant, steel construction.
- Fully engineered and tested to resist the adverse effects of vibration.
- Mounting band feet are designed to ensure maximum torque pressure, continuously.
- Gauge of steel increases as diameter of mounting band increases.
- Bright stainless models available.
- Bolt and nut included with mounting band.
- Used on all Axial Seal Air Cleaners and FRG Radial Seal Air Cleaners.



Most of our Air Cleaners with metal housings require two mounting bands.

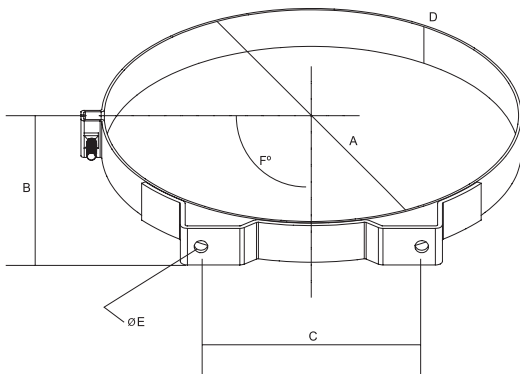

| Part Number | Dimensions (mm) | | | | | |
|-------------|-----------------|-------|------|----|---------|-----|
| | A | B | C | D | E | F |
| P004055 | 111 | 68 | 82,5 | 19 | 9,0 | 90 |
| P002348 | 134 | 81 | 82 | 22 | 9,0 | 90 |
| P002351 | 153 | 91 | 83 | 26 | 9,0 | 90 |
| P007191 | 165 | 99 | 95 | 22 | 11 X 16 | 90 |
| P004906 | 178 | 105 | 111 | 22 | 10 X 13 | 90 |
| E500206 | 203 | 114 | 108 | 25 | 12 X 17 | 90 |
| P004307 | 203 | 114 | 108 | 25 | 9 | 90 |
| P004073 | 229 | 130 | 114 | 32 | 12 | 90 |
| P004076 | 259 | 146 | 127 | 32 | 12 | 90 |
| H770025* | 259 | 146 | 127 | 32 | 12 | 90 |
| P004079 | 279 | 156 | 127 | 32 | 11 | 90 |
| H000349 | 300 | 175 | 152 | 38 | 11 | 90 |
| P013722 | 330 | 184 | 152 | 38 | 10 | 90 |
| H770065 | 330 | 206 | 203 | 38 | 12 | 90 |
| H770059 | 345 | 191,5 | 142 | 38 | 10 | 90 |
| H000350 | 356 | 206 | 203 | 38 | 12 | 90 |
| P016845 | 381 | 203 | 203 | 38 | 12 | 90 |
| H000351 | 407 | 231 | 254 | 38 | 12 | 90 |
| H770037 | 457 | 234 | 400 | 50 | 14 | 105 |
| H770068 | 546 | 279 | 490 | 48 | 14 | 105 |

* With cage nut

Extends Filter Life in Extremely Heavy Dust Conditions

The Donaspin Pre-Cleaner extends the life your air filter by removing up to 90% of the dirt and contaminant before it reaches the filter and ejecting it automatically via the exhaust. (See page 124-125 for Exhaust Ejectors.)

Donaspin is designed especially for equipment operating in very heavy dust/debris environments such as garbage trucks, agricultural vehicles and mining equipment.

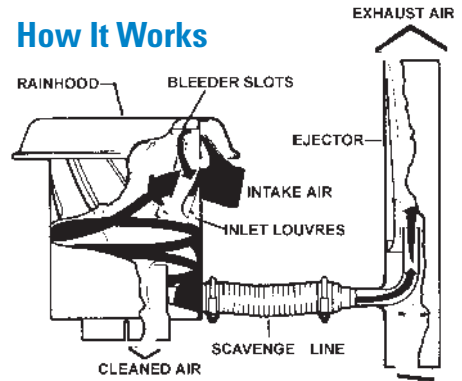

Application

- For engine airflows of 9-22 m³/min.
- Recommended mounting: on top of the air inlet stack

Features

- Built-in louvers spin air to separate up to 90% of incoming dirt and debris from the air intake system
- Works as part of a scavenged flow system to continuously expel pre-cleaned contaminants through the exhaust flow
- Durable, corrosion-resistant steel construction
- High efficiency with low restriction
- No maintenance! Self-cleaning! No moving parts!
- Mounting clamp is included

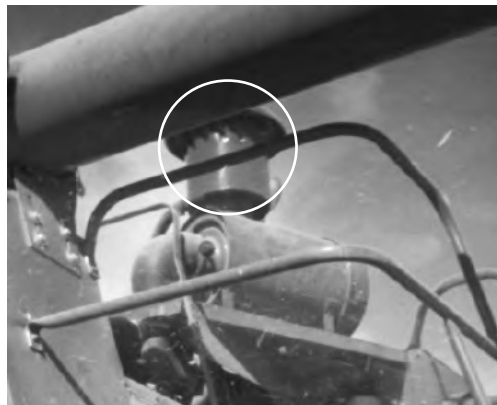

The Donaspin installed on this combine removes most of the incoming dirt, then directs the contaminant out of the system with the exhaust gases.

To create a scavenged flow system, combine the Donaspin with a Donaldson exhaust ejector and ejector check valve.

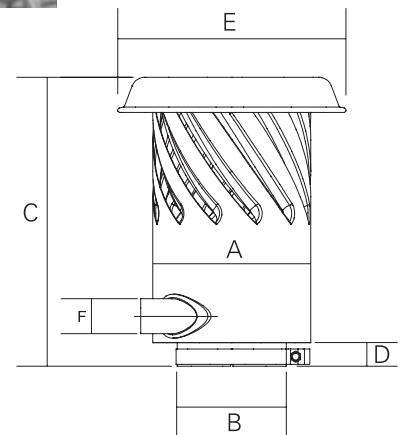

| Part Number | Rated Airflow (m ³ /min) @ 12,5 mbar added | Dimensions | | | | | |
|-------------|---|------------|--------------|---------|---------|---------|---------|
| | | A mm | B (ID) mm | C mm | D mm | E mm | F mm |
| H001212 | 9 | 203 | 76 | 304 | 55 | 305 | 32 |
| H001307 | 11 | 203 | 96 | 292 | 42 | 305 | 32 |
| H001215 | 13 | 203 | 115 | 284 | 28 | 305 | 32 |
| H001308 | 15 | 203 | 128 | 283 | 33 | 305 | 32 |
| H001375 | 22 | 229 | 154 | 373 | 34 | 330 | 32 |

Extends Filter Life on Agricultural & Construction Equipment

Donaldson has a new Pre-Cleaner called TopSpin™. Before you consider replacing your Full-View Pre-Cleaner with another one, check out the TopSpin models on page 132 and 133.



| Full-View Pre-Cleaners | TopSpin™ Pre-Cleaners |
|------------------------|-----------------------|
| H000820 | H002425 |
| H000821 | H002426 |
| H000822 | H002394 |
| H000823 | H002427 |
| H001250 | H002435 |
| H001251 | H002436 |
| H001249 | H002437 |
| H001823 | H002434 |
| H002043 | H002433 |
| H002044 | H002432 |
| H002045 | H002431 |
| H002223 | H002438 |
| H002224 | H002439 |

Features

- Recommended mounting: on top of the engine intake stack.
- Centrifugal force in bowl separates up to 75% of incoming dust before it enters the engine air intake system.
- Low maintenance!
- Durable, lightweight, noncorrosive construction.
- Full-View plastic bowl lets operator easily see when service is needed.
- One-bolt cover retention for service when dirt reaches the level of the arrow, remove top nut and plastic body then empty – no tools required.
- Mounting clamp included.

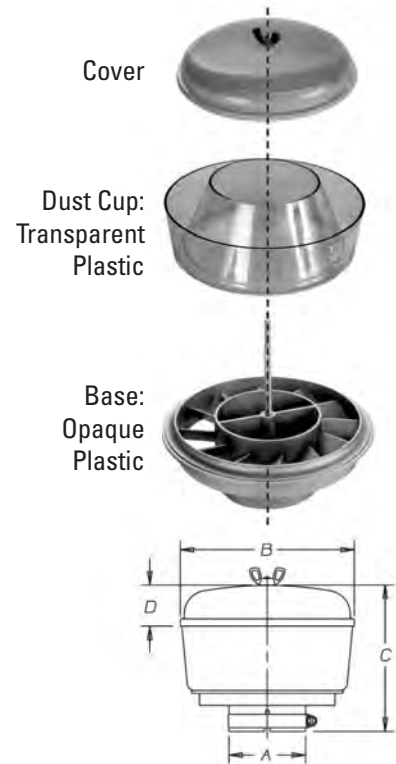

| Full-View PreCleaner | Replacement Parts | | | Max Airflow (m ³ /min.) | Inlet OD | | | |
|----------------------|-------------------|---------|---------|------------------------------------|----------|------|-------|------|
| | Cover | Bowl | Clamp | | A mm | B mm | C mm | D mm |
| H002041 | P020116 | P020115 | P532924 | 2 | 35 | 142 | 142,5 | 44 |
| H002042 | P020116 | P020115 | P115200 | 2 | 44 | 142 | 142,5 | 44 |
| H002040 | P020116 | P020115 | P115200 | 2,5 | 51 | 142 | 142,5 | 44 |
| H001250 | P020648 | P020227 | P115201 | 4 | 57 | 186 | 157 | 44 |
| H001251 | P020648 | P020227 | P115201 | 4 | 64 | 186 | 157 | 44 |
| H001249 | P020648 | P020227 | P143422 | 5 | 77 | 186 | 157 | 44 |
| H000820 | P016548 | P016330 | P143422 | 9 | 77 | 270 | 190 | 47 |
| H000821 | P016548 | P016330 | P115202 | 9 | 96 | 270 | 188 | 47 |
| H000822 | P016548 | P016330 | P115202 | 9,5 | 102 | 270 | 189 | 47 |
| H000823 | P016548 | P016330 | P115203 | 10 | 115 | 270 | 188 | 47 |
| H002043 | P020345 | P020344 | P115203 | 21 | 127 | 306 | 195 | 51 |
| H002223 | P104691 | P158324 | - | 37 | 152 | 412 | 258 | 70 |
| H002224 | P104691 | P158324 | - | 42,5 | 178 | 412 | 258 | 70 |

Extends Filter Life in Extremely Heavy Dust Conditions

Donaldson TopSpin™ will extend primary air filter life, boost system efficiency and extend engine life! We recently upgraded the cover material of the TopSpin Pre-Cleaner to **increase impact resistance**. Before it was a see-through unit, now it is **black**.

Features

Separates up to 85% of incoming contaminant per ISO 5011/SAE J726

- Greatly extends air filter life
- Reduces air filter usage
- Lowers cost per operating hour
- Automatically ejects mixed debris
- Separates more than 99% of 20 micron and above particles

Operates at a lower RPM

- Less noise
- Longer bearing life
- Lower restriction

Self-cleaning/self-scavenging

- No maintenance to clean bowl
- No exhaust ejector required

Easy installation

- Quick installation
- One clamp to tighten
- No wires or power requirements

Dual mounted bearings

- More robust design
- Extends bearing life

Lighter Weight

- Lighter than competitive pre-cleaners
- Lighter than Donaldson full-view pre-cleaner

Application

- Engine airflows of 2-43 m³/min.
- Primarily used in medium to heavy dust environments
- Great for off-road vehicles and equipment from crawler tractors to farm tractors to skid steer loaders
- Recommended mounting: on top of the air cleaner inlet stack



Donaldson TopSpin mounted on a grader. The aerodynamically designed TopSpin™ is made of a lightweight, durable, non-corroding material which makes it tolerant to all weather and operating conditions.

More than 99% of contaminant 20 micron and larger is expelled

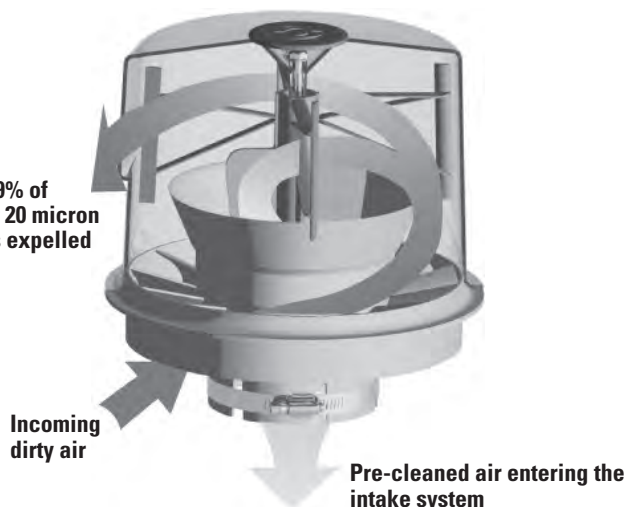

- Can be mounted horizontally or vertically
- Installation instructions, stainless clamp / warranty are included
- Operating temperature range: to 82°C

TopSpin™ Specifications

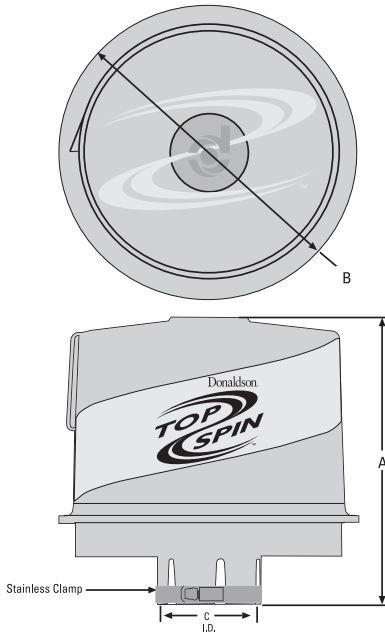

| Part Number | Outlet I.D. (C) mm | Overall Height (A) mm | Body Dia. (B) mm | Operating Flow Range m ³ /min. |
|-------------|--------------------|-----------------------|------------------|---|
| H002434 | 51,5 | 146 | 162 | 2,5 - 6 |
| H002435 | 58 | 146 | 162 | 2,5 - 6 |
| H002436 | 64 | 146 | 162 | 2,5 - 6 |
| H002437 | 77 | 146 | 162 | 2,5 - 6 |
| H002425 | 78 | 238 | 242 | 6 - 13 |
| H002426 | 97 | 238 | 242 | 6 - 13 |
| H002394 | 103 | 238 | 242 | 6 - 13 |
| H002431 | 103 | 287 | 288 | 13 - 21 |
| H002427 | 116 | 238 | 242 | 6 - 13 |
| H002432 | 116 | 287 | 288 | 13 - 21 |
| H002433 | 128 | 287 | 288 | 13 - 21 |
| H002438 | 153 | 345 | 397 | 21 - 42,5 |
| H002439 | 179 | 345 | 397 | 21 - 42,5 |

Cross References from Full View to TopSpin™ Pre-Cleaner can be found on page 131.

TopSpin™ Performance Curves

Multiple tests conducted per ISO 5011/SAE J726 and average results are shown in charts below.

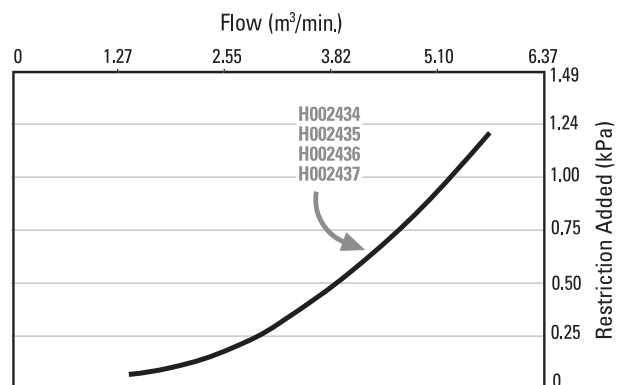
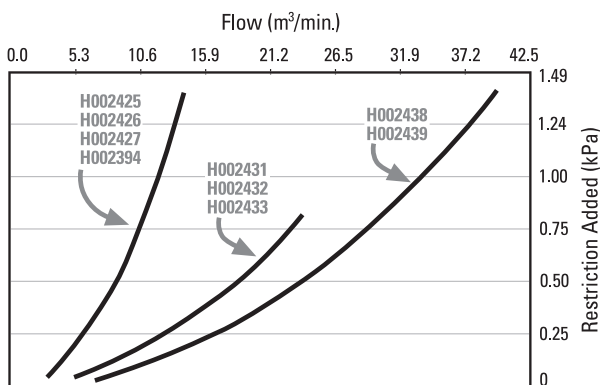

Rain Caps Protect Against Large Debris Ingestion

- Protects engine air intake from rain, snow, birds, and other large contaminants.
- Mounts on stack or directly to air cleaner for on-road and off-road equipment.
- Two styles in a wide variety of sizes.
- Installs easily with one clamp which is included.

Style A

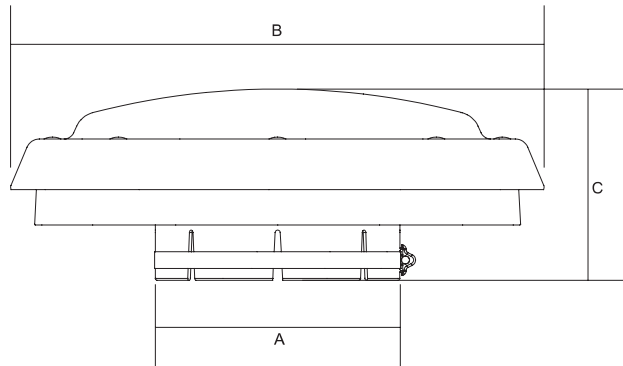

Style B

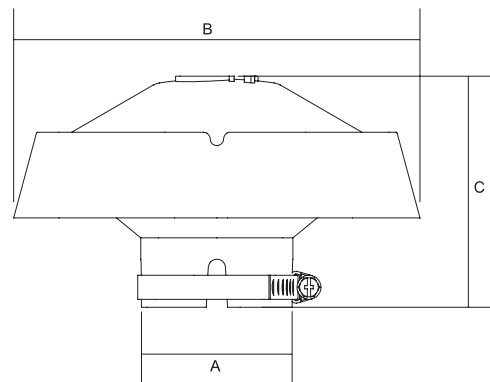

| Style | Part Number | Dimensions (mm) | | |
|-------|-------------|-----------------|-----|-----|
| | | A | B | C |
| A | H770066 | 45 | 110 | 56 |
| B | H001377 | 52 | 152 | 86 |
| B | H001378 | 64 | 152 | 86 |
| B | H001379 | 77 | 152 | 86 |
| B | H770010 | 96 | 266 | 132 |
| B | H770081 | 97 | 200 | 140 |
| B | H770011 | 102 | 266 | 130 |
| B | H770012 | 115 | 266 | 126 |
| B | H770013 | 128 | 266 | 123 |
| B | H770090 | 154 | 405 | 144 |
| B | H770089 | 179 | 405 | 144 |
| A | H001053 | 207 | 405 | 157 |
| A | H770082 | 254 | 406 | 189 |

Filter Service Indicators Maximize Filter Life Mounting Options: On air cleaner outlet tube, on intake duct or remote

Replacing filters based on restriction readings can reduce your maintenance costs significantly. Visual inspection of air filters is not adequate and should not dictate service life. Filters that appear very dirty may still contain a great amount of service life.

Over-servicing and excessive handling of the filter can result in serious consequences: filter damage, improper installation, intake contamination from ambient dust, and/or increased service cost, time and material. In contrast, filter service based on restriction readings can enable you to obtain: the longest life possible from the filter, and the best engine protection.

Restriction Readings, Where & When

Restriction readings are normally taken at the air cleaner on the clean side of the air filter. If the air cleaner does not have a restriction tap, readings can be taken anywhere in the system between the air cleaner and the engine. To measure restriction of a naturally aspirated diesel engine, the reading is taken at full-governed RPM with no load.

Two methods are used to measure the restriction of turbo-charged engines. The **first method** is to take the reading with the truck on a dynamometer under full load. This result is actual restriction.

A locking step gauge is the **second method**. This popular method will give actual, on-the-road peak readings.

Maximum Restriction Limits for Engines

Maximum allowable restriction limits are set by the engine manufacturers. If your maximum limit is unknown, contact your engine manufacturer for the maximum limits.

Maximum levels are measured at high idle with no load for naturally aspirated and super-charged diesel engines. Turbo-charged diesel, gasoline and carbureted engines are measured at full load with a wide open throttle.

Choose Restriction Measurement Tools that Best Fit Your Applications

Donaldson offers a variety of restriction measuring devices that help you get maximum filter utilization. All measure restriction in inches of water vacuum. All are resistant to vibration, breakage, weather, corrosion, dust and dirt to assure reliable filter restriction readings.

Types of Indicators

Continuous Reading devices show how much life is left in the filter:

- The Informer™ Mechanical Indicators

Go/No-Go restriction readings on heavy-duty vehicles:

- ServiSignal™
- Electrical Indicator
- Electrical Indicator with AMP Connector



Filter service indicators are very effective when mounted on the outlet tube of the air cleaner, as is The Informer™ above. This gives the operator constant & accurate visibility of filter life.

Mechanical Indicators

| Part Number | Restriction mbar | Limits Pa | mm H2o | Fitting |
|-------------|------------------|-----------|--------|---------|
|-------------|------------------|-----------|--------|---------|

ServiSignal™ Mini Indicators

| | | | | |
|---------|----|------|-----|-------------|
| X002250 | 37 | 3700 | 380 | 1/8"-27 NPT |
| X002251 | 50 | 5000 | 508 | 1/8"-27 NPT |
| X002252 | 62 | 6200 | 635 | 1/8"-27 NPT |
| X002254 | 75 | 7500 | 762 | 1/8"-27 NPT |

Informer™ Indicators

| | | | | |
|---------|----|------|-----|-------------|
| X002278 | 50 | 5000 | 508 | 1/8"-27 NPT |
| X002277 | 62 | 6200 | 635 | 1/8"-27 NPT |
| X002275 | 75 | 7500 | 762 | 1/8"-27 NPT |

ServiSignal™ Mini Indicator

Small enough to fit just about anywhere (only 42 mm high), the Donaldson ServiSignal™ shows a highly visible, bright red flag in the full-view window when restriction limit is reached. Resets manually via top button after air cleaner service. Kit includes 1/8" NPT threaded brass fitting for mounting on the air cleaner. For remote mount, also order P105168 flange. Hoses are not included.



The Informer™ for Graduated, Continuous Readings

The Informer, when mounted on the air cleaner or the dashboard, provides a continuous reading whether the engine is running or is shut down. Reset button is on top. Kit includes full installation instructions and a P100089 safety filter fitting. For remote mounting, order a P105168 flange and a P105622 90° elbow.



Electrical Indicators

| Part Number | Restriction mbar | Limits Pa | mm H2o | Fitting |
|-------------|------------------|-----------|--------|---------|
|-------------|------------------|-----------|--------|---------|

Electrical Indicators

| | | | | |
|---------|----|------|-----|-------------|
| X770037 | 37 | 3700 | 380 | 1/8"-27 NPT |
| X770050 | 50 | 5000 | 508 | 1/8"-27 NPT |
| X770052 | 50 | 5000 | 508 | M10 X 1 |
| X770061 | 62 | 6200 | 635 | M10 X 1 |
| X770062 | 62 | 6200 | 635 | 1/8"-27 NPT |
| X770075 | 75 | 7500 | 762 | 1/8"-27 NPT |

Electrical Indicators with AMP connectors

| | | | | |
|---------|----|------|-----|-------------|
| X770225 | 64 | 6400 | 627 | M10 X 1 |
| X770301 | 54 | 5400 | 530 | M10 X 1 |
| X770316 | 54 | 5400 | 530 | 1/8"-27 NPT |
| X770317 | 64 | 6400 | 627 | 1/8"-27 NPT |
| X770526 | 75 | 7500 | 762 | 1/8"-27 NPT |

Electrical Indicators

Connects to Light, Buzzer, or Computer

- Designed for a variety of on- and off-highway applications.
- Should be screwed on the air cleaner nipple by hand.
- Operating temperatures of -10°C to +100°C.
- When restriction level reaches the maximum recommended limit, an electrical signal activates a light, a buzzer, or a computer.
- The indicator automatically resets itself after the filter is serviced.
- 12-24 Volts.
- Maximum load: 6 watts (light or buzzer).
- Contacts have no polarity.
- Switch contacts are normally in the open position.
- If inductive load can occur, appropriate protection must be provided.
- Quick connectors and light, buzzer, or computer must be purchased separately.



Flexible rubber adapters and elbows have smooth radii and inside surfaces to minimize flow resistance within the air intake system. These rubber products are heavy duty.

Specifications

- EPDM rubber construction for improved heat resistance and low temperature flexibility (to 100°C).
 - Non corrosive construction resists tears, punctures, and vacuum collapse under severe conditions.
 - Ideal for light-, medium- and heavy-duty applications.
 - Elbows ribbed or compounded for extra strength and durability.
- Rubber adapters help to absorb vibrations and reduce intake noise level.



90° Elbows & Elbow Reducers



| 90° Elbows | | | | |
|-------------|----------------|-----|-----|--------------|
| Part Number | Dimension (mm) | | | Outer Dia mm |
| | A | B | R | |
| P781509 | 45 | 80 | 51 | 51 |
| P105529 | 50 | 89 | 51 | 61 |
| P105530 | 57 | 95 | 57 | 67 |
| P105531 | 63 | 102 | 64 | 76 |
| P105532 | 76 | 127 | 83 | 89 |
| P114318 | 89 | 140 | 102 | 102 |
| P105533 | 102 | 146 | 105 | 114 |
| P113733 | 114 | 140 | 89 | 127 |
| P107844 | 127 | 156 | 115 | 140 |
| P105534 | 140 | 165 | 121 | 153 |
| P105535 | 152 | 171 | 127 | 165 |
| P105536 | 178 | 192 | 141 | 194 |
| P112605 | 203 | 216 | 165 | 223 |
| P114314 | 254 | 267 | 216 | 273 |

| 90° Elbow Reducers | | | | | |
|--------------------|----------------|-----|-----|-----|--------------|
| Part Number | Dimension (mm) | | | | Outer Dia mm |
| | A | B | C | R | |
| P781510 | 40 | 45 | 80 | 45 | 46 - 51 |
| P778565 | 76 | 60 | 65 | 70 | 71 - 87 |
| P775228 | 76 | 70 | 113 | 60 | 82 - 88 |
| P123462 | 76 | 89 | 89 | 57 | 89 - 102 |
| P121482 | 127 | 102 | 146 | 95 | 114 - 140 |
| P143895 | 152 | 127 | 178 | 108 | 140 - 165 |
| P159820 | 178 | 127 | 178 | 108 | 140 - 190 |
| P128990 | 178 | 140 | 146 | 111 | 156 - 194 |
| P117724 | 152 | 140 | 170 | 127 | 152 - 165 |

45° Elbows & Elbow Reducers

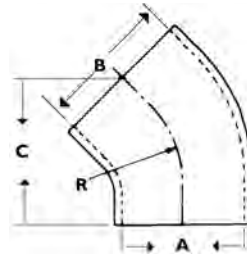
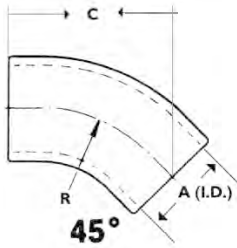

45° Elbows

| Part Number | Dimension (mm) | | | Outer Dia mm |
|-------------|----------------|-----|-----|--------------|
| | A | C | R | |
| P105541 | 50 | 102 | 51 | 61 |
| P105542 | 56 | 105 | 57 | 67 |
| P105543 | 64 | 110 | 64 | 74 |
| P105544 | 76 | 140 | 95 | 89 |
| P109331 | 89 | 127 | 89 | 102 |
| P105545 | 102 | 140 | 108 | 114 |
| P114316 | 114 | 129 | 89 | 127 |
| P109021 | 127 | 143 | 115 | 140 |
| P105546 | 140 | 159 | 121 | 153 |
| P105547 | 153 | 165 | 127 | 165 |
| P105548 | 178 | 203 | 141 | 194 |
| P112606 | 203 | 203 | 165 | 222 |
| P114313 | 254 | 241 | 216 | 273 |

45° Elbow Reducers

| Part Number | Dimension (mm) | | | | Outer Dia mm |
|-------------|----------------|-----|-----|-----|--------------|
| | A | B | C | R | |
| P133338 | 152 | 140 | 164 | 124 | 153 - 165 |
| P133339 | 153 | 178 | 184 | 135 | 168 - 194 |



Straight Humps

| Part Number | Dimension (mm) | | Outer Dia mm |
|-------------|----------------|-----|--------------|
| | A | B | |
| P781511 | 45 | 50 | 51 |
| P105608 | 76 | 135 | 89 |
| P114319 | 89 | 134 | 102 |
| P105609 | 102 | 134 | 115 |
| P114317 | 114 | 153 | 127 |
| P105610 | 127 | 153 | 140 |
| P105611 | 140 | 153 | 153 |
| P105612 | 153 | 178 | 165 |
| P105613 | 178 | 178 | 191 |
| P112608 | 203 | 127 | 216 |
| P111414 | 254 | 153 | 267 |

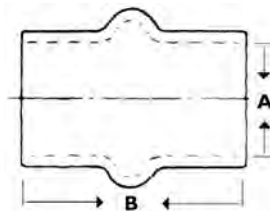

Hump Reducers

| Part Number | Dimension (mm) | | | Outer Dia mm |
|-------------|----------------|-----|-----|--------------|
| | A | B | C | |
| P102820 | 76 | 64 | 114 | 75 - 89 |
| P520883 | 76 | 70 | 89 | 83 - 89 |
| P520882 | 89 | 70 | 102 | 80 - 99 |
| P101290 | 89 | 76 | 127 | 89 - 102 |
| P520884 | 102 | 70 | 102 | 80 - 111 |
| P101291 | 102 | 76 | 134 | 89 - 114 |
| P101292 | 102 | 89 | 134 | 102 - 114 |
| P101293 | 127 | 102 | 153 | 114 - 140 |
| P101891 | 140 | 102 | 153 | 114 - 153 |
| P103516 | 140 | 127 | 153 | 140 - 153 |
| P112611 | 153 | 127 | 153 | 140 - 165 |
| P101294 | 153 | 140 | 153 | 153 - 165 |
| P126530 | 178 | 140 | 178 | 153 - 191 |
| P112610 | 178 | 153 | 153 | 165 - 191 |
| P136494 | 178 | 127 | 178 | 140 - 191 |
| P129660 | 203 | 140 | 178 | 152 - 216 |
| P114315 | 203 | 153 | 153 | 165 - 216 |
| P112609 | 203 | 178 | 153 | 191 - 216 |
| P112607 | 254 | 203 | 153 | 216 - 267 |

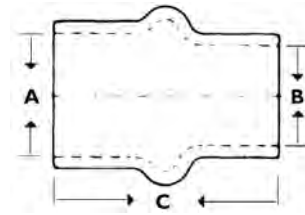

Reducers

| Part Number | Dimension (mm) | | | Outer Dia mm |
|-------------|----------------|----|----|--------------|
| | A | B | C | |
| P114411 | 38 | 26 | 64 | 36 - 49 |
| P114412 | 38 | 32 | 64 | 42 - 49 |
| P104087 | 51 | 38 | 64 | 49 - 61 |
| P102948 | 51 | 45 | 64 | 55 - 61 |
| P104088 | 57 | 51 | 64 | 61 - 68 |
| P104089 | 64 | 51 | 64 | 62 - 75 |
| P104090 | 64 | 58 | 64 | 68 - 74 |

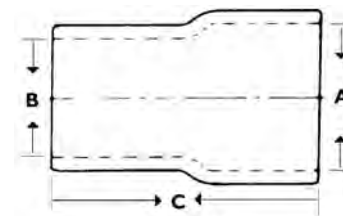

Isolate Intake Piping Vibration

Our three styles of charge air connectors are designed to ease connections in air intake system piping: they compensate for slight misalignment and isolate vibration between hose connections. The silicone elastomer material resists chemicals, steam, ozone, coolants and aging conditions normally found in any engine operating environment.

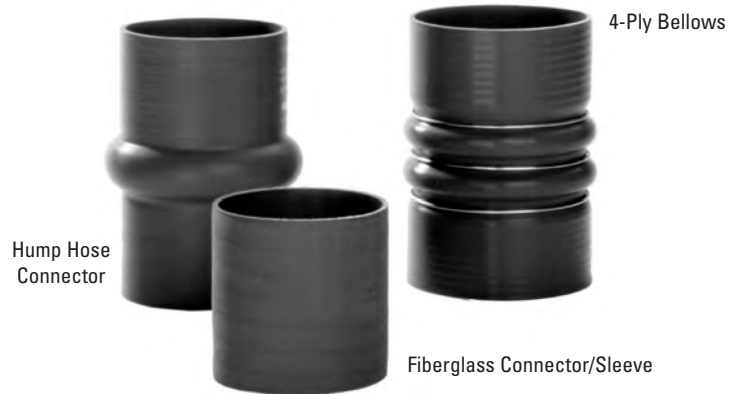

All three charge air connectors are for installation on the pressure side with maximum operating temperatures up to 260°C. They are orange in color to be easily identifiable as tolerant of high temperatures.

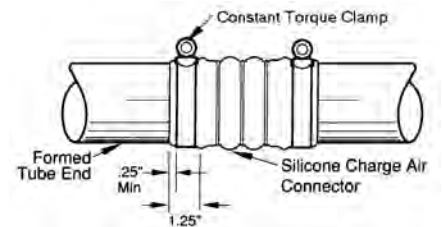
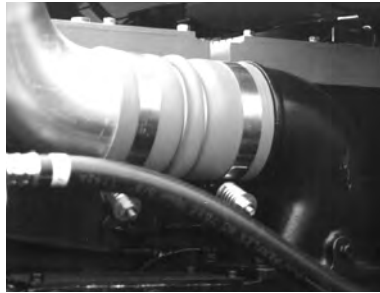

Use the illustration as a guide for installing your Silicone Charge Air Connector.

Connectors/Sleeves

| Part Number | Inner Dia mm | Outer Dia mm | Length mm |
|-------------|--------------|--------------|-----------|
| P532946 | 32 | 38 | 914 |
| P532947 | 38 | 44 | 914 |
| P532948 | 51 | 57 | 914 |
| P532949 | 57 | 63 | 914 |
| P532950 | 64 | 69 | 914 |
| P532951 | 76 | 82 | 914 |
| P532952 | 86 | 92 | 89 |
| P532953 | 86 | 92 | 152 |
| P532954 | 86 | 92 | 914 |
| P532956 | 89 | 95 | 89 |
| P532957 | 89 | 95 | 114 |
| P532958 | 89 | 95 | 914 |
| P532959 | 102 | 107 | 914 |

Hump Hose Connectors

| Part Number | Inner Dia mm | Outer Dia mm | Length mm |
|-------------|--------------|--------------|-----------|
| P532960 | 63,5 | 72 | 140 |
| P532961 | 70 | 78 | 108 |
| P532962 | 76 | 85 | 111 |

4-Ply Bellows

| Part Number | Inner Dia mm | Outer Dia mm | Length mm | No of rings |
|-------------|--------------|--------------|-----------|-------------|
| P535572 | 89 | 95 | 152 | 3 |
| P532943 | 102 | 107 | 152 | 0 |
| P535571 | 102 | 107 | 152 | 2 |
| P532944 | 102 | 107 | 152 | 3 |
| P532945 | 102 | 107 | 191 | 3 |
| P535573 | 102 | 107 | 203 | 3 |

Replace Damaged or Missing Vacuator™ Valves Immediately!

The Vacuator™ Valve, standard on the majority of Donaldson air cleaners, is an important part of the functionality of the air cleaner. It is an integral part of the pre-cleaning stage on two-stage air cleaners.

The dust cup, where pre-cleaned dust is collected, is normally under a slight vacuum when the engine is running. The normal engine pulsing of the vacuum causes the Vacuator™ Valve to open and close. This action automatically expels any collected dust and water. The Vacuator Valve also unloads when the engine is stopped.



The Donaldson Vacuator Valve is made in a variety of sizes and shapes to fit various applications. The Donaldson part number is molded into each part for easy identification.

Application Notes

- For proper operation, the Vacuator™ Valve should be located at the lowest point on the air cleaner or dust cup pointing down.
- Never paint the Vacuator Valve. Solvents and chemicals will shorten the usable life.
- If the Vacuator Valve is torn, shredded or turned inside out, its durometer may be too soft for the application. Choose a model with a harder durometer (higher number). Conversely, if the Vacuator Valve doesn't empty itself properly, the durometer may be too hard. Choose one with a softer durometer (lower number.)

| Part Number | Diameter | Durometer |
|-------------|----------|-----------|
| P103198 | 76 | 40 |
| P105220 | 76 | 60 |
| P106593 | 76 | 60 |
| P112803 | 76 | 40 |
| P149099 | 25 | 60 |
| P158914 | 51 | 50 |
| P522958 | 51 | 60 |
| P525956 | 25 | 60 |
| P775569 * | 51 | 60 |
| P776008 | 51 | 60 |

* 45° Vacuator Valve

For the longest filter service life, replace damaged or missing Vacuator™ Valves immediately!

If your valve is cracked, torn, remains open or is missing, dust particles that are normally expelled can deposit themselves onto the filter and will shorten air filter service life. Replace it!

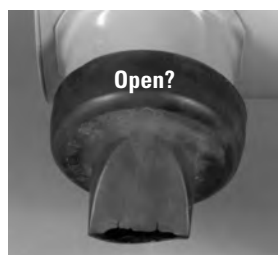

On-Line Product Info

is **More Current**

Than Printed Materials!

While we know printed product information will not disappear anytime soon, more and more people are choosing to use our on-line literature informational tools as a product resource. Not only is it the most current information and it's available 24/7!

<http://www.emea.donaldson.com/en/engine/support/datalibrary/index.html>

The screenshot displays the Donaldson Europe Cross References website. The header includes the Donaldson logo and navigation links: Home, Search/Cross References, Product Catalog, How to Buy, Our Brands, and Contact Us. The main content area is titled "Product Literature" and features a search bar on the right. The left sidebar contains a navigation menu with categories: ENGINE + VEHICLE, Product Overview, Air Filtration, Lube/Fuel/Coolant Filtration, Hydraulics Filtration, Extended Service, Where To Buy, Contact Us, Product Literature, Customer Support, Frequently Asked Questions, News, and Events. The main content area lists various product literature items, including General, Warranty, Air Filtration, Endurance™ Extended Service Filters, and Liquid Filtration. A small advertisement for Donaldson Europe Cross References is visible on the right side of the page.

Proper Air Cleaner Service is Essential

Proper air cleaner servicing results in maximum engine protection against the ravages of dust.

Proper servicing can also save you time and money by maximizing filter life and air cleaning efficiency.

Two of the most common problems are:

Over Servicing

New filters increase in dust cleaning efficiency as dust builds up on the media. Don't be fooled by filter appearance! A used filter should look dirty. By using proper filter measurement tools, you will use the full life of the filter at maximum efficiency.

Improper Servicing

Your engine is vulnerable to abrasive dust contaminants during the servicing process. The most common cause of engine damage is improper servicing procedures.

By following the steps listed in this section, you can avoid unnecessary risk to the engine.

Section Index

| | |
|-----------------------------|-----|
| Air Filter Cleaning | 144 |
| Air Filter Inspection | 145 |
| General Tips..... | 146 |

Check out at the end of each Air Cleaner Section the Service Instructions.

Donaldson recommends to service Air Filters by monitoring the airflow restriction levels in the air intake system

Some vehicle owners and maintenance supervisors, concerned with lowering their operating costs, clean and reuse their heavy-duty air filter.

Factors to consider before you decide whether cleaning or washing of air filters is appropriate for your vehicle or fleet:

- Heavy-duty air filter manufacturers do not recommend any type of cleaning process be used on their products. Donaldson, like other heavy-duty air filter manufacturers, does not warrant the air filter once it has been cleaned.
- Damaged filters should not be cleaned or reused. If the filter is damaged in service, investigate the source of damage and make corrections to avoid future damage.
- Never attempt to clean a safety element. Replace it after three main element services.
- Rather than cleaning or reusing filters, consider upgrading to an extended service filter and service the filter by restriction indicators. Donaldson recommends, when the specified maximum service limits are reached, to follow the proper service procedures and replace the used filter with a new Donaldson filter. Dispose of the used filter in a responsible manner.



Filter dirt holding capacity is reduced 20-40% with each cleaning.

There is a risk of dirt reaching the clean side of the filter while cleaning, plus possible filter damage from high pressure water or compressed air, makes cleaning or washing a gamble. Add the cost of cleaning to the danger of filter damage when determining the risk versus the value of filter cleaning process.

Reuse of cleaned heavy duty filters increases the likelihood of improper air cleaner servicing because of the shortened service life. Each time the air intake system is serviced, it is exposed to the possibility of contamination.

What is a Hole and What is a False Alarm?

Donaldson receives filters for inspection each year that customers believe have developed holes. Upon inspection and testing in our labs, most of these suspect filters prove to have no holes or leaks. Most often these filters have areas with low dust buildup where light comes through the media when inspected with a light inside the filter, but in fact the filter functions perfectly.

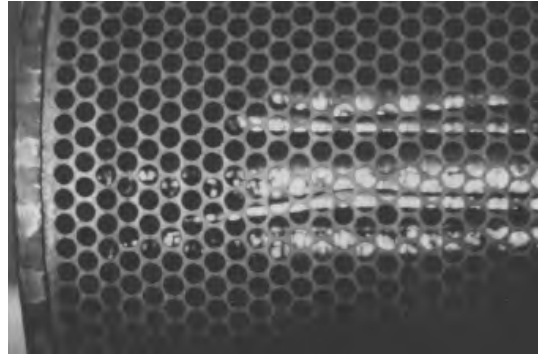

On this photo, it is apparent that the filter has low dust buildup on the pleats or folds, but is functioning efficiently - no holes, no leaks.

How do you tell the difference between a hole and low dust build-up?

The problem is that normal dust buildup shuts out light completely, while low dust buildup permits light to shine through the media. The contrast is significant and therefore looks like a crack or hole in the media. The contrast between a leak and low dust buildup is not as pronounced, which accounts for mis-identifications.

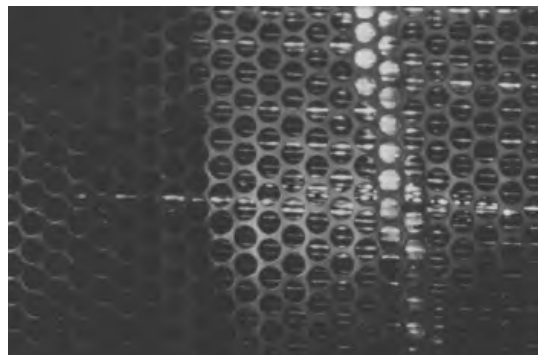

Here, light is coming through the adhesive beaded area as well as at the folds. Again no holes, no leaks.

The deceiving low dust areas appear most often at the fold or at the adhesive beading present on some filters.

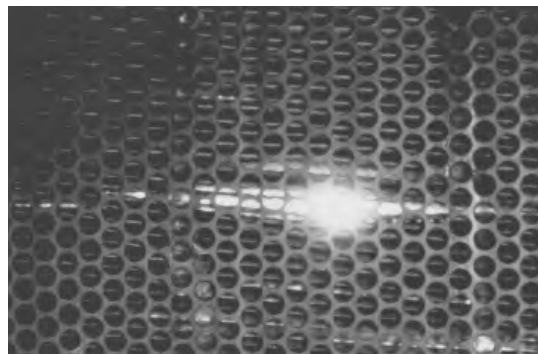

As you look at the photo on the left, you can see it shows a hole in the media. The other light areas are not holes, but rather more low dust areas on the adhesive beading, which is used for pleat spacing.

The secret to identifying a hole in the filter is to realize that when a hole is present you actually see the bright lamp filament shining through the hole, while low dust buildup is merely a bright area where the media is folded and not covered with dust.

Another basic sign of a hole is dust on the liner or endcap of the clean air side of the filter. If there is no sign of dust on the clean-side liner of the filter you can be quite sure that there is no leak in the filter.

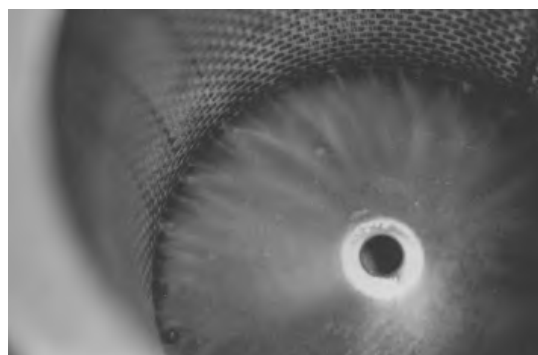

In this last example, there are obvious dust trails on the liner or endcap of the clean air side of the filter. A dust trail usually indicates a leak.

1 Don't Remove Filter for Inspection

Such a check will always do more harm than good. Ridges of dirt on the gasket sealing surface can drop on the clean filter side when the gasket is released. Stick with the regular maintenance schedule, or, if you service by restriction, believe the gauge or restriction indicator. Get a new indicator if you don't trust your current one.



2 Never Rap a Filter to Clean It

Rapping hard enough to knock off dust damages the filter and destroys your engine protection. Deeply embedded dirt is never released by tapping. It is always safer to keep operating until you can change to a new filter.



3 Never Judge the Filters Life by looking at it. Measure the Airflow Restriction

A dirty-looking filter may still have plenty of life left, while carbon contamination may not be visible to the eye. You can't see the dirt that's embedded deep within the filter paper. Your best bet for lowest filter maintenance costs and best engine protection is to follow a restriction indicator. It's a smart, low-cost investment.



4 Never Leave an Air Cleaner open longer than necessary

Your open air cleaner is a direct entry to the engine! Keep it protected during filter changes. Contaminants smaller than we can see will cause damage to a diesel engine. If the housing is not going to be reassembled immediately, cover the opening. The only way to be sure nothing got in, is to make sure nothing can get in!



5 Don't Ignore a Worn or Damaged Gasket in the Housing

If your air cleaner has a cover gasket, replace it with a new one. Always check to be sure that no piece of the old gasket remains in the housing and that the gasket is not worn. If your filter model calls for a new gasket with each use, never reuse the old one.



6 Don't Use a Damaged or Bunched Filter

Never install a dented or punctured filter because it cannot protect properly against contamination. A dent can make a firm seal impossible or can indicate damaged media. A filter with bunched pleats saps engine power and fuel euros.

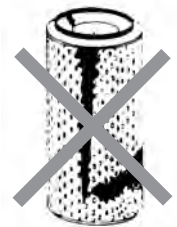

7 Replace Missing or Damaged Parts

Check to ensure that there is no damage to the air cleaner housing that could cause a leak. Replace any missing or damaged Vacuator Valves and air cleaner fasteners. Never attempt to repair a damaged filter.



8 Never Substitute an Incorrect Filter Model Number

Filters may look almost identical, but even a fraction of a mm difference in size can prevent a good seal or affect airflow. Selecting a filter by size may give you the wrong media area and grade and therefore affect service life and filter efficiency.



| Style | Air Cleaner Model No. | Main Element | Safety Element | Cover Assembly | Vacuator™ Valve | Gasket | Wing Nut Assy | Mounting Band | Rain Cap | Status |
|-------|-----------------------|--------------|----------------|----------------|-----------------|---------|---------------|---------------|----------|------------|
| EBA | A092029 | P129472 | | P141787 | | P120597 | | P004073 | | Production |
| EBA | A092040 | P140822 | | | | P120597 | | P004073 | | Cancelled |
| EBA | A110029 | P772512 | | | | | | | | Cancelled |
| EBA | A130071 | P182007 | | | | | | P013722 | | Cancelled |
| FVA | A140003 | P181000 | | P118808 | | P017335 | P018464 | H000350 | H770013 | Cancelled |
| FVA | A140033 | P181000 | | P118807 | P103198 | P017335 | P018464 | H000350 | H770013 | Cancelled |
| FVA | A140206 | P181000 | | P118807 | P103198 | P017335 | P018464 | H000350 | H770013 | Cancelled |
| FVA | A140208 | P181000 | | | | | | | | Cancelled |
| FGA | A144800 | P016688 | | | | | | | | Cancelled |
| FGA | A144900 | P016688 | | P016996 | | | | | | Cancelled |
| FGA | A161500 | P782261 | | P782268 | | | | | | Production |
| FKB | B045008 | P604457 | P603729 | P606497 | P158914 | | | | | Production |
| FKB | B055006 | P609218 | P602427 | P609219 | P158914 | | | | | Production |
| FKB | B065045 | P609221 | P608599 | P608592 | P158914 | | | | | Production |
| ELB | B065011 | P772552 | | | | | | P007191 | H001379 | Production |
| ELB | B065012 | P772552 | P770181 | | | | | P007191 | H001379 | Production |
| FLB | B065018 | P772565 | P770207 | | | | P138403 | P007191 | | Production |
| EPB | B070005 | P772579 | P775300 | P778758 | | | | P777731 | H001379 | Production |
| ELB | B080009 | P772529 | | | | | | P004307 | H770010 | Production |
| ELB | B080010 | P772529 | P119410 | | | | | P004307 | H770010 | Production |
| ELB | B080017 | P774517 | P771363 | | | | | | | Cancelled |
| ERB | B080018 | P770829 | P770735 | | | | P101870 | | | Cancelled |
| ERB | B080019 | P770828 | P127787 | | | | P101870 | E500206 | H770010 | Cancelled |
| FLB | B080022 | P772556 | P119410 | | | | P138403 | P004307 | | Production |
| ELB | B080024 | P774517 | P771363 | | | | P101870 | | H001379 | Production |
| ELB | B080031 | P772529 | | | | | | E500206 | H770011 | Cancelled |
| ELB | B080033 | P772529 | P119410 | | | | P101870 | P004307 | | Cancelled |
| ELB | B080039 | P776146 | P776147 | | | | P181070 | E500206 | H770010 | Cancelled |
| ELB | B080040 | P774517 | P771363 | | | | P101870 | | H770010 | Production |
| FLB | B080046 | P778702 | P775457 | | | | P138403 | E500206 | | Production |
| EPB | B080067 | P772580 | P775302 | P775305 | | | | P777732 | H770010 | Production |
| XRB | B080080 | P611190 | P611189 | P605731 | P158914 | | | | | Production |
| ERB | B090010 | P182092 | P119778 | P134945 | | | P101870 | P004073 | H770012 | Cancelled |
| ERB | B090019 | P182092 | | P134945 | | | P101870 | P004073 | H770012 | Cancelled |
| ERB | B090023 | P182092 | P119778 | P134945 | | P137368 | P101870 | P004073 | H770012 | Cancelled |
| ELB | B090047 | P777230 | P777247 | | | | P101870 | P004073 | H770011 | Cancelled |
| SRB | B095437 | P780522 | P780523 | P782176 | | | | P004073 | | Production |
| ERB | B100035 | P182090 | P119375 | P128443 | | P128707 | P101870 | P004076 | H770012 | Production |
| ERB | B100037 | P182090 | P119375 | | | | | | | Cancelled |
| ERB | B100041 | P117439 | P123828 | P128443 | | | P101870 | P004076 | H770012 | Cancelled |
| ERB | B100044 | P182090 | P119375 | P128443 | | P128707 | P101870 | P004076 | H770012 | Production |
| ERB | B100046 | P182090 | P119375 | | | | | | | Cancelled |
| ELB | B100057 | P772522 | P133138 | | | | P138403 | P004076 | H770012 | Production |
| FLB | B100067 | P772530 | P133138 | | | | P138403 | P004076 | | Production |
| ELB | B100068 | P772522 | | | | | | P004076 | H770012 | Production |
| ELB | B100071 | P772522 | P133138 | | | | P138403 | P004076 | H770012 | Production |
| ELB | B100072 | P772527 | P123828 | | | | P775455 | P004076 | H770013 | Production |
| ELB | B100075 | P774538 | P775005 | | | | P138403 | P004076 | H770012 | Production |
| ELB | B100078 | P774547 | P775035 | | | | P138403 | P004076 | H770012 | Cancelled |
| ERB | B100120 | P778214 | P777639 | P777998 | | | | P004076 | H770012 | Cancelled |
| SRB | B100121 | P778214 | P777639 | P777998 | | | | P004076 | | Production |
| ERB2 | B100126 | P785388 | P770685 | P784954 | | | | P004076 | H770012 | Production |
| XRB | B100127 | P611539 | P611540 | P609942 | P158914 | | | | | Production |
| ERB | B110154 | P778905 | P778906 | P783014 | | | | P004079 | H770013 | Cancelled |
| SRB | B110155 | P778905 | P778906 | P783014 | | | | P004079 | | Production |
| ERB | B120153 | P182091 | P130772 | | | | P130501 | H000349 | H770013 | Cancelled |
| ERB | B120190 | P182091 | P130772 | | | | P130501 | H000349 | H770013 | Cancelled |
| ERB | B120246 | P182091 | | | | | | | | Cancelled |
| FLB | B120260 | P772520 | P770678 | | | | P138403 | H000349 | | Production |
| ELB | B120265 | P772524 | P770678 | | | | P138403 | H000349 | H770013 | Production |
| ELB | B120268 | P772524 | | | | | | H000349 | H770013 | Production |
| ELB | B120290 | P772524 | P770678 | | | | P138403 | H000349 | H770013 | Production |
| STB | B120319 | P772524 | P770678 | | | | P138403 | H000349 | | Production |
| ERB | B120395 | P536315 | P529286 | P529798 | | | | | | Cancelled |
| XRB | B120470 | P608116 | P608391 | P608117 | P158914 | | | | | Production |
| ERB | B130010 | P777279 | | P777300 | | | | P013722 | H770089 | Cancelled |
| ERB | B130013 | P777279 | P777414 | P777300 | | | | P013722 | H770089 | Cancelled |
| ERB | B130028 | P781768 | | P781784 | P533226 | | | P013722 | H770089 | Production |
| SRB | B130046 | P777409 | P777414 | P781124 | | | | P013722 | | Production |
| SPB2 | B130048 | P783543 | X770684 | P783693 | | | | Integrated | | Production |
| ERB2 | B130057 | P785610 | | P783693 | | | | P013722 | H770089 | Production |
| ERB2 | B130058 | P785610 | X770686 | P783693 | | | | P013722 | H770089 | Production |
| SPB2 | B130060 | P783543 | X770684 | P783693 | | | | Integrated | | Production |
| ERB | B140139 | P182002 | P119373 | P770605 | | P017335 | P775455 | H000350 | H000606 | Production |
| EGB | B140159 | P772523 | | P776172 | | P017335 | | H000350 | H000606 | Production |
| EGB | B140167 | P772523 | P119373 | P776172 | | P017335 | P775455 | H000350 | H000606 | Production |
| EGB | B140175 | P772521 | | P776172 | | P017335 | | H000350 | H000606 | Production |
| EGB | B140176 | P772521 | P119373 | P776172 | | P017335 | P775455 | H000350 | H000606 | Production |
| EGB | B140317 | P775026 | P776102 | P782130 | | P017335 | P770920 | H000350 | H770089 | Production |
| ERB | B150025 | P777871 | P777875 | P777861 | | | | P016845 | H770089 | Cancelled |

Service Parts by Air Cleaner Model



| Style | Air Cleaner Model No. | Main Element | Safety Element | Cover Assembly | Vacuator™ Valve | U-Clip Mounting (x4) | Wing Nut Assy | Mounting Band | Rain Cap | Status |
|-------|-----------------------|--------------|----------------|----------------|-----------------|----------------------|---------------|---------------|----------|------------|
| ERB | B150028 | P777871 | | P777861 | | | | P016845 | H770089 | Cancelled |
| ERB | B150030 | P777871 | | P777920 | P158914 | | | P016845 | H770089 | Production |
| ERB2 | B150058 | P785426 | X770687 | P784869 | | | | P016845 | H770089 | Production |
| ERB2 | B150059 | P785426 | | P784869 | | | | P016845 | H770089 | Production |
| ETB | B180002 | P182042 | P128408 | P780042 | | | P109062 | H770037 | H001053 | Production |
| ERB | B180011 | P781098 | | P783186 | | | | H770037 | H770082 | Cancelled |
| ERB | B180012 | P781098 | P781102 | P783186 | | | | H770037 | H770082 | Cancelled |
| ERB2 | B180016 | P785394 | | P785546 | | | | H770037 | H770082 | Production |
| ERB2 | B180017 | P785394 | X770688 | P785546 | | | | H770037 | H770082 | Production |
| PSD | D080020 | P608533 | P600975 | P602985 | P158914 | | | | | Production |
| PSD | D080026 | P608533 | P600975 | P601735 | P158914 | | | | | Production |
| PSD | D080069 | P608533 | P600975 | P785236 | P112803 | P786050 | | | | Production |
| PSD | D080070 | P608533 | P600975 | P785237 | P112803 | P786050 | | | | Production |
| PSD | D090019 | P608665 | P606121 | P609550 | P158914 | | | | | Production |
| PSD | D090020 | P608665 | P606121 | P609550 | P158914 | | | | | Production |
| PSD | D090021 | P608675 | P606121 | P609552 | P158914 | | | | | Production |
| PSD | D090022 | P608675 | P606121 | P609552 | P158914 | | | | | Production |
| PSD | D090073 | P608665 | P606121 | P785651 | P112803 | P784517 | | | | Production |
| PSD | D090074 | P608665 | P606121 | P785651 | P112803 | P784517 | | | | Production |
| PSD | D090086 | P608665 | P606121 | P785651 | P112803 | P784517 | | | | Production |
| PSD | D090087 | P608665 | P606121 | P785651 | P112803 | P784517 | | | | Production |
| PSD | D090088 | P787281 | P606121 | P785978 | P112803 | P784517 | | | | Production |
| PSD | D090089 | P787281 | P606121 | P785978 | P112803 | P784517 | | | | Production |
| PSD | D090090 | P608675 | P606121 | P786989 | P112803 | P784517 | | | | Production |
| PSD | D090091 | P608675 | P606121 | P786989 | P112803 | P784517 | | | | Production |
| PSD | D090098 | P787281 | P606121 | P785978 | P112803 | P784517 | | | | Production |
| PSD | D090099 | P787281 | P606121 | P785978 | P112803 | P784517 | | | | Production |
| PSD | D090100 | P608675 | P606121 | P786989 | P112803 | P784517 | | | | Production |
| PSD | D090101 | P608675 | P606121 | P786989 | P112803 | P784517 | | | | Production |
| PSD | D100029 | P608666 | P601560 | Upon Request | P112803 | P784517 | | | | Production |
| PSD | D100030 | P608666 | P601560 | Upon Request | P112803 | P784517 | | | | Production |
| PSD | D100031 | P608676 | P601560 | Upon Request | P112803 | P784517 | | | | Production |
| PSD | D100032 | P608676 | P601560 | Upon Request | P112803 | P784517 | | | | Production |
| PSD | D100121 | P608676 | P601560 | Upon Request | P112803 | P784517 | | | | Production |
| PSD | D100122 | P608676 | P601560 | Upon Request | P112803 | P784517 | | | | Production |
| PSD | D100123 | P608666 | P601560 | Upon Request | P112803 | P784517 | | | | Production |
| PSD | D100124 | P608666 | P601560 | Upon Request | P112803 | P784517 | | | | Production |
| PSD | D120035 | P608667 | P607557 | Upon Request | P112803 | P784517 | | | | Production |
| PSD | D120036 | P608667 | P607557 | Upon Request | P112803 | P784517 | | | | Production |
| PSD | D120037 | P608677 | P607557 | Upon Request | P112803 | P784517 | | | | Production |
| PSD | D120038 | P608677 | P607557 | Upon Request | P112803 | P784517 | | | | Production |
| HFD | D770065 | P772506 | P139293 | L012244 | | | P126054 | | | Production |
| HFD | D770098 | P772506 | P139293 | | | | P126054 | | | Cancelled |
| HFD | D770099 | P772506 | P139293 | | | | P126054 | | | Cancelled |
| HFD | D770100 | P770035 | | | | | | | | Cancelled |
| HFD | D770105 | P770991 | | | | | | | | Cancelled |
| HFD | D770106 | P772506 | P139293 | | | | | | | Cancelled |
| HFD | D770108 | P182041 | P119370 | | | | | | | Cancelled |
| HFD | D770109 | P772506 | P139293 | | | | | | | Cancelled |
| HFD | D770112 | P772506 | P139293 | | | | | | | Cancelled |
| HFD | D770117 | P772506 | P139293 | L016193 | | | P126054 | | | Production |
| HFD | D770121 | P772506 | P139293 | | | | | | | Cancelled |
| FWA | G042503 | P102745 | | P102755 | | | P102783 | P004055 | H770066 | Production |
| FPG | G042546 | P822686 | | P777153 | P522958 | | | P777151 | H770066 | Production |
| FPG | G042575 | P822686 | P535396 | P777153 | P522958 | | | P777151 | H770066 | Production |
| FHG | G050003 | P182050 | | P129355 | | | P101870 | P002348 | H001377 | Production |
| FHG | G052567 | P108736 | P118745 | | | | | | | Cancelled |
| FHG | G052568 | P108736 | P120949 | E500171 | P522958 | | P101870 | P002348 | | Production |
| FHG | G052595 | P182050 | | P129355 | | | P101870 | P002904 | H001377 | Production |
| FHG | G052596 | P182050 | P120949 | P129355 | | | P101870 | P002904 | H001377 | Production |
| FHG | G052667 | P182050 | P120949 | P129355 | | | P181070 | P002904 | H001377 | Cancelled |
| FPG | G057502 | P772578 | P775298 | P775308 | P522958 | | | P777730 | H771377 | Production |
| FPG | G057504 | P772578 | | P775308 | P522958 | | | P777730 | H001377 | Production |
| FPG | G057505 | P775631 | | P775308 | P522958 | | | P777730 | H001377 | Production |
| FWA | G065008 | P181052 | | P102805 | | | P101870 | P007191 | H001378 | Production |
| FWA | G065055 | P101222 | | | | | | | | Cancelled |
| FHG | G065100 | P119135 | P114500 | P111857 | P522958 | | P101870 | P007191 | H001379 | Cancelled |
| FHG | G065101 | P119135 | P114500 | P102805 | | | P101870 | P002940 | H001379 | Production |
| FWA | G065110 | P182052 | | P102805 | | | P101870 | P002940 | H001378 | Cancelled |
| FHG | G065124 | P119135 | | P102805 | | | P101870 | P002940 | H001379 | Cancelled |
| FHG | G065188 | P119135 | P114500 | P103836 | P105220 | | P101870 | P002940 | H001379 | Cancelled |
| FHG | G065207 | P130760 | P126984 | P111857 | P522958 | | P101870 | P002940 | H001379 | Cancelled |
| FHG | G065211 | P130760 | | P111857 | P522958 | | P101870 | P002940 | H001379 | Cancelled |
| FHG | G065221 | P774510 | P770049 | P111857 | P522958 | | P181070 | P002940 | | Cancelled |
| FKG | G065222 | P137293 | P137285 | | | | | | | Cancelled |
| FKG | G065223 | P137293 | | | | | | | | Cancelled |
| FHG | G065228 | P100760 | | P111857 | P522958 | | P181070 | P002940 | | Cancelled |
| FKG | G065229 | P137293 | | | | | | | | Cancelled |
| FHG | G065251 | P774510 | P770049 | | | | | | | Cancelled |
| FLB | G065259 | P772549 | P770181 | | P522958 | | P138403 | P002940 | H001379 | Production |
| FLB | G065260 | P772549 | | | P522958 | | | | | Production |
| FHG | G065310 | P130760 | P126984 | P111857 | P522958 | | P101870 | P002940 | H001379 | Cancelled |

Service Parts

| Style | Air Cleaner Model No. | Main Element | Safety Element | Cover Assembly | Vacuator™ Valve | Gasket | Wing Nut Assy | Mounting Band | Rain Cap | Status |
|-------|-----------------------|--------------|----------------|----------------|-----------------|---------|---------------|---------------|----------|------------|
| FLB | G065311 | P772549 | P770181 | | | | | | | Cancelled |
| FHG | G065322 | P130760 | P126984 | P111857 | P522958 | | P101870 | P002940 | H001379 | Cancelled |
| FLB | G065337 | P771250 | P771270 | | P522958 | | P130501 | | | Production |
| FLB | G065346 | P771549 | | | P522958 | | | P002940 | | Production |
| FKG | G065350 | P771459 | P771460 | | P522958 | | P138403 | P002940 | | Production |
| FTG | G065357 | P775140 | P121643 | | | | P138403 | | | Cancelled |
| FVA | G065390 | P182052 | | P102805 | | | P101870 | P002940 | | Cancelled |
| FVA | G065401 | P132978 | | P527908 | P522958 | | P101870 | | | Cancelled |
| FLB | G065425 | P776675 | P776676 | | P522958 | | P138403 | P002940 | H001379 | Cancelled |
| FPG | G065497 | P822768 | P822769 | P780401 | P522958 | | | P778810 | H001378 | Production |
| FPG | G065498 | P822768 | | P780401 | P522958 | | | P778810 | H001378 | Production |
| FPG | G065499 | P822768 | P822769 | P780401 | P522958 | | | P778810 | H001378 | Production |
| FPG | G065500 | P822768 | | P780401 | P522958 | | | P778810 | H001378 | Production |
| FPG | G065539 | P532410 | | P780466 | P522958 | | | P778810 | H001378 | Production |
| FPG | G070006 | P772579 | P775300 | P775311 | P522958 | | | P777731 | H001379 | Production |
| FPG | G070009 | P772579 | | P775311 | P522958 | | | P777731 | H771379 | Production |
| FPG | G070015 | P776156 | | P775311 | P522958 | | | P777731 | H771379 | Cancelled |
| FPG | G070059 | P772579 | P775300 | P778758 | P522958 | | | P777731 | H001379 | Production |
| FPG | G070060 | P772579 | | P778758 | P522958 | | | P777731 | H001379 | Production |
| FPG | G070135 | P783498 | P775300 | P778758 | P522958 | | | P777731 | H001379 | Production |
| FVA | G080026 | P182054 | | | P112803 | | | P004307 | H001379 | Cancelled |
| FVA | G080119 | P182054 | | | | | | | | Cancelled |
| FHG | G080195 | P182059 | | P103113 | | | P101870 | P003951 | H770010 | Cancelled |
| FHG | G080200 | P182059 | P119410 | P103113 | | | P101870 | P003951 | H770010 | Production |
| FHG | G080227 | P182059 | P119410 | | | | | | | Cancelled |
| FHG | G080307 | P182059 | P119410 | | | | | | | Cancelled |
| FHG | G080308 | P182059 | P119410 | | | | | | | Cancelled |
| FHG | G080322 | P772564 | P127787 | P119711 | P158914 | | P101870 | P004307 | | Cancelled |
| FHG | G080364 | P774572 | P775284 | P103840 | P112803 | | P101870 | P004307 | | Cancelled |
| FHG | G080365 | P774572 | P775284 | P103113 | | | P101870 | P004307 | H770010 | Cancelled |
| FLB | G080377 | P772550 | P119410 | | P158914 | | P101870 | P004307 | H770010 | Production |
| FHG | G080394 | P182059 | P119410 | | | | | | | Cancelled |
| FHG | G080395 | P772564 | P127787 | | P158914 | | P101870 | P004307 | | Cancelled |
| FLB | G080430 | P772550 | | | P158914 | | | P004307 | H770010 | Production |
| FLB | G080433 | P772553 | P127787 | | | | | | | Cancelled |
| FHG | G080440 | P182059 | | | | | | | | Cancelled |
| FLB | G080442 | P772554 | | | | | | | | Production |
| FHG | G080458 | P772564 | P127787 | | | | | | | Cancelled |
| FLB | G080459 | P772550 | | | | | | | | Cancelled |
| FHG | G080463 | P182059 | P119410 | P103837 | P112803 | | P101870 | P004307 | H770010 | Cancelled |
| FVA | G080466 | P181054 | | | | | | | | Cancelled |
| FVA | G080467 | P181054 | | P781341 | | | | | | Cancelled |
| FHG | G080513 | P182059 | P119410 | P103840 | P112803 | | P101870 | P004307 | | Cancelled |
| FLB | G080516 | P772550 | | | P158914 | | | P004307 | | Production |
| FLB | G080536 | P772550 | P119410 | | P158914 | | P101870 | P004307 | H770010 | Production |
| FLB | G080538 | P776677 | P776678 | | P158914 | | P101870 | P004307 | H770010 | Cancelled |
| FPG | G082503 | P772580 | P775302 | P775305 | P775569 | | | P777732 | H770010 | Production |
| FPG | G082505 | P772580 | | P775305 | P775569 | | | P777732 | H770010 | Production |
| FPG | G082508 | P772580 | P775302 | P775305 | P522958 | | | P777732 | H770010 | Production |
| FPG | G082511 | P772580 | | P775305 | P522958 | | | P777732 | H770010 | Cancelled |
| FPG | G082580 | P828889 | P829333 | P780403 | P158914 | | | P780580 | H770010 | Production |
| FPG | G082581 | P828889 | | P780403 | P158914 | | | P780580 | H770010 | Production |
| FPG | G082582 | P828889 | P829333 | P780403 | P158914 | | | P780580 | H770010 | Production |
| FPG | G082583 | P828889 | | P780403 | P158914 | | | P780580 | H770010 | Production |
| FPG | G082671 | P828889 | | P782865 | P775569 | | | P777732 | H770010 | Production |
| FPG | G082677 | P828889 | | P782865 | P775569 | | | P777732 | H770010 | Production |
| FHG | G090022 | P182063 | P119778 | | P112667 | | P101870 | P102025 | H770012 | Production |
| FHG | G090024 | P182063 | | | P112667 | | P101870 | P102025 | H770012 | Production |
| FHG | G090031 | P182063 | P119778 | | | | | | | Cancelled |
| FHG | G090046 | P182063 | P119778 | P128968 | | | P101870 | P004073 | | Cancelled |
| EKG | G090148 | P138428 | | | P149099 | P137368 | | P004073 | H770090 | Cancelled |
| FHG | G090185 | P774569 | P775283 | | P112667 | | P101870 | P004073 | H770012 | Cancelled |
| FHG | G090190 | P182063 | P119778 | P775725 | P112803 | | P101870 | P004073 | | Cancelled |
| FHG | G090203 | P182063 | P119778 | P112667 | | | P101870 | P004073 | | Cancelled |
| FPG | G090219 | P780522 | P780523 | P780524 | P776008 | | | P780532 | H770012 | Production |
| FPG | G090220 | P780522 | | P780524 | P776008 | | | P780532 | H770012 | Production |
| FPG | G090225 | P780522 | P780523 | P780524 | P776008 | | | P780532 | H770012 | Production |
| FPG | G090226 | P780522 | | P780524 | P776008 | | | P780532 | H770012 | Production |
| FVA | G100003 | P182045 | | P103519 | | P101401 | | P004076 | H770011 | Cancelled |
| FVA | G100004 | P182045 | | P103827 | P103198 | P101401 | | P004076 | H770011 | Production |
| FHG | G100028 | P182064 | | P103519 | | E500589 | P101870 | P106071 | H770012 | Cancelled |
| FHG | G100029 | P182064 | P119375 | P103519 | | E500589 | P101870 | P106071 | H770012 | Cancelled |
| FHG | G100035 | P182064 | | P103827 | P105220 | E500589 | P101870 | P004076 | H770012 | Cancelled |
| FHG | G100036 | P182064 | P119375 | P103827 | P103198 | P101401 | P111852 | P004076 | H770012 | Cancelled |
| STB | G100129 | P182090 | P119375 | P128443 | | E500589 | P101870 | P002940 | | Cancelled |
| FHG | G100143 | P772545 | P133138 | P133141 | P103198 | P128707 | P101870 | P004076 | H770012 | Cancelled |
| STB | G100154 | P182090 | P119375 | P128443 | | E500589 | P101870 | P002940 | | Cancelled |
| STB | G100180 | P182090 | P119375 | | | | | | | Cancelled |
| FVA | G100184 | P772503 | | P103827 | P105220 | E500589 | P101870 | P004076 | H770012 | Cancelled |
| FHG | G100185 | P182064 | P133138 | P103519 | | E500589 | P101870 | P004076 | H770012 | Cancelled |
| FLB | G100220 | P772555 | P133138 | | P103198 | | P138403 | P004076 | H770012 | Production |
| FLB | G100221 | P772555 | | | P103198 | | | P004076 | H770012 | Production |

Service Parts by Air Cleaner Model



Service Parts

| Style | Air Cleaner Model No. | Main Element | Safety Element | Cover Assembly | Vacuator™ Valve | Gasket | Wing Nut Assy | Mounting Band | Rain Cap | Status |
|-------|-----------------------|----------------|----------------|----------------|-----------------|---------|---------------|---------------|----------|------------|
| FLB | G100254 | P776301 | P133138 | | P103198 | | P138403 | P004076 | H770012 | Cancelled |
| FLB | G100257 | P772555 | P133138 | | P103198 | | P138403 | P004076 | H770012 | Production |
| FLB | G100258 | P776679 | P776680 | | P103198 | | P138403 | P004076 | H770012 | Cancelled |
| FRG | G100271 | P777389 | P777388 | P777455 | P776008 | | | P004076 | H770012 | Cancelled |
| FPG | G100274 | P777588 | | P777589 | P158914 | | | INTEGRATED | P776343 | Production |
| FPG | G100275 | P777592 | | P777593 | P158914 | | | INTEGRATED | P776343 | Production |
| FPG | G100280 | P777588 | P777779 | P776182 | P158914 | | | INTEGRATED | P776343 | Production |
| FRG | G100281 | P777638 | P777639 | P777455 | P776008 | | | P004076 | H770012 | Cancelled |
| FRG | G100284 | P777638 | | P777455 | P776008 | | | P004076 | H770012 | Cancelled |
| FPG | G100285 | P777592 | P778776 | P777593 | P158914 | | | INTEGRATED | P776343 | Cancelled |
| FLB | G100315 | P772555 | P133138 | | P103198 | | P138403 | P004076 | H770012 | Cancelled |
| FPG | G100317 | P781039 | P777639 | P780578 | P776008 | | | P780594 | H770012 | Production |
| FPG | G100318 | P781039 | | P780578 | P776008 | | | P780594 | H770012 | Production |
| FPG | G100319 | P781039 | P777639 | P780578 | P776008 | | | P780594 | H770012 | Production |
| FPG | G100320 | P781039 | | P780578 | P776008 | | | P780594 | H770012 | Production |
| FLB | G100362 | P780067 | P780068 | | | | | | | Production |
| FPG | G100378 | P781039 | P777639 | P780578 | P775569 | | | P780594 | H770012 | Production |
| FRG2 | G100420 | P785589 | X770689 | P784944 | P776008 | | | P004076 | H770012 | Production |
| FRG2 | G100428 | P785589 | | P784944 | P776008 | | | P004076 | H770012 | Production |
| FRG | G110211 | P778905 | P778906 | P778366 | P158914 | | | P004079 | H770013 | Cancelled |
| FRG | G110269 | P778905 | P778906 | P778366 | P158914 | P782257 | | P004079 | H770013 | Cancelled |
| FRG2 | G110381 | P785396 | X770690 | P784923 | P158914 | | | P004079 | H770013 | Production |
| FRG2 | G110382 | P785396 | X770690 | P784923 | P158914 | | | P004079 | H770013 | Production |
| FRG | G118329 | P821938 | P821963 | P821825 | P806891 | P830922 | | P004079 | | Cancelled |
| FHG | G120012 | P182034 | | P106589 | | P017804 | P111852 | H000349 | H770013 | Production |
| FHG | G120014 | P182034 | P119374 | P106589 | | P017804 | P111852 | H000349 | H770013 | Production |
| FHG | G120036 | P182034 | P119374 | P109296 | P103198 | P017804 | P111852 | H000349 | H770013 | Cancelled |
| FHG | G120037 | P182034 | | P109296 | P105220 | P017804 | P111852 | H000349 | H770013 | Cancelled |
| FHG | G120269 | P182034 | P119374 | P106589 | | P017804 | P111852 | P100808 | H770013 | Production |
| FWA | G120305 | P772504 | | | | | | | | Cancelled |
| FLB | G120309 | P772531 | P770678 | | P105220 | | P138403 | H000349 | H770013 | Production |
| FLB | G120310 | P772531 | | | P105220 | | | H000349 | H770013 | Production |
| STG | G120332 | - See page 115 | | | | | | | | Production |
| FLB | G120359 | P772531 | P770678 | | | | | | | Production |
| FLB | G120368 | P772531 | P770678 | | P105220 | | P138403 | H000349 | H770013 | Cancelled |
| STB | G120369 | P182044 | P119371 | P109194 | | P017804 | X004816 | | | Cancelled |
| FLB | G120386 | P781301 | P781302 | | P105220 | | P138403 | H000349 | H770013 | Production |
| FRG | G130061 | P777409 | P777414 | P777408 | P776008 | | | P013722 | H770090 | Cancelled |
| FRG | G130087 | P777409 | | P777408 | P776008 | | | P013722 | H770090 | Cancelled |
| FRG | G130088 | P777409 | P777414 | P777408 | P776008 | | | P013722 | H770090 | Cancelled |
| FRG | G130113 | P777409 | | P777408 | P775569 | | | P013722 | H770090 | Cancelled |
| FRG | G130120 | P780331 | P780332 | P777408 | P776008 | | | P013722 | H770090 | Cancelled |
| FRG | G130164 | P781822 | P781826 | P777408 | P776008 | | | P013722 | H770090 | Production |
| FRG2 | G130232 | P785390 | X770691 | P784892 | P776008 | | | P013722 | H770090 | Production |
| FRG2 | G130233 | P785390 | | P784892 | P776008 | | | P013722 | H770090 | Production |
| FRG2 | G130234 | P785390 | X770691 | P784892 | P776008 | | | P013722 | H770090 | Production |
| FRG2 | G130235 | P785390 | | P784892 | P775569 | | | P013722 | H770090 | Production |
| FRG2 | G130236 | P785398 | X770692 | P784892 | P776008 | | | P013722 | H770090 | Production |
| ERG | G132034 | P777579 | | P776947 | P158914 | | | | | Cancelled |
| ERG | G132036 | P532503 | P532504 | P780533 | | P778220 | | P013722 | H770013 | Cancelled |
| FTG | G138217 | P777776 | P777777 | P777709 | P806891 | | P126054 | P013722 | | Cancelled |
| FHG | G140022 | P182046 | P119373 | P106773 | | P017335 | P775455 | P100866 | H770090 | Production |
| FHG | G140023 | P182046 | | P106773 | | P017335 | P111852 | P100866 | H770090 | Cancelled |
| FHG | G140054 | P182046 | P119373 | P109297 | P105220 | P017335 | P775455 | P100866 | H770090 | Production |
| FHG | G140055 | P182046 | | P109297 | P103198 | P017335 | P111852 | H000350 | H770090 | Cancelled |
| STB | G140059 | P182041 | P119370 | P109084 | | P017335 | X004816 | | | Production |
| STG | G140076 | - See page 114 | | | | | | | | Production |
| FWA | G140181 | P117331 | | | | | | | | Cancelled |
| FHG | G140393 | P182046 | | | | | | | | Cancelled |
| EBA | G140420 | P772523 | | P770597 | | | | | | Cancelled |
| FHG | G140435 | P182046 | | | | | | | | Cancelled |
| FHG | G140436 | P182046 | P119373 | P118784 | | P017335 | P775455 | H000350 | H770090 | Cancelled |
| FHG | G140442 | P182046 | P119373 | | | | | | | Cancelled |
| STG | G140445 | - See page 115 | | | | | | | | Production |
| EBA | G140494 | P772523 | P119373 | P775240 | | P017335 | P775455 | H000350 | H770090 | Cancelled |
| EBA | G140496 | P772523 | P119373 | P775240 | | P017335 | P775455 | H000350 | H770090 | Production |
| FTG | G140570 | P182046 | | P771385 | P105220 | P017335 | P111852 | | | Cancelled |
| FTG | G150029 | P772536 | P771073 | P771178 | P103198 | | P111852 | P016845 | H770089 | Production |
| FTG | G150032 | P774537 | | P771178 | P103198 | P771179 | P111852 | P016845 | H770089 | Production |
| FTG | G150033 | P772567 | | P771178 | P103198 | P771179 | P111852 | P016845 | H770089 | Production |
| FTG | G150034 | P772567 | | P771178 | P103198 | P771179 | P111852 | P016845 | H770089 | Cancelled |
| FTG | G150035 | P772536 | P771073 | P771178 | P103198 | | P111852 | P016845 | H770089 | Production |
| FTG | G150037 | P772536 | | P771178 | P103198 | | P111852 | P016845 | H770089 | Production |
| FTG | G150043 | P772581 | P775339 | P771178 | P103198 | P771179 | P111852 | P016845 | H770089 | Production |
| FTG | G150076 | P772567 | | P771178 | P103198 | P771179 | P111852 | P016845 | | Cancelled |
| FRG | G150092 | P777868 | P777869 | P777920 | P776008 | | | P016845 | H770089 | Cancelled |
| FTG | G150096 | P772567 | P777938 | P771178 | P103198 | P771179 | P111852 | P016845 | H770089 | Cancelled |
| FRG | G150097 | P777868 | | P777920 | P776008 | | | P016845 | H770089 | Cancelled |
| SSG | G150104 | P777871 | P777875 | P777861 | P112803 | P017336 | | | | Production |
| FRG | G150111 | P777868 | P777869 | P777920 | P776008 | | | P016845 | H770089 | Production |

| Style | Air Cleaner Model No. | Main Element | Safety Element | Cover Assembly | Vacuator™ Valve | Gasket | Wing Nut Assy | Mounting Band | Rain Cap | Status |
|-------|------------------------|--------------|----------------|----------------|-----------------|---------|---------------|---------------|----------|-----------------------|
| FRG | G150112 | P777868 | P777869 | P777920 | P776008 | | | P016845 | H770089 | Cancelled |
| FRG | G150117 | P778764 | P778765 | | | | | | | Cancelled |
| FTG | G150165 | P772536 | | P771178 | P103198 | P771179 | P111852 | P016845 | H770089 | Cancelled |
| FRG | G150168 | P781187 | P777875 | P777861 | | | | P016845 | H770089 | Cancelled |
| FRG | G150169 | P781187 | P777875 | P777861 | | | | P016845 | H770089 | Cancelled |
| FRG | G150207 | P781909 | | P777920 | P776008 | | | P016845 | H770089 | Cancelled |
| FRG | G150215 | P778674 | P777875 | P777920 | P158914 | | | P016845 | H770089 | Cancelled |
| FRG2 | G150255 | P785590 | X770693 | P785551 | P776008 | | | P016845 | H770089 | Production |
| FRG2 | G150256 | P785590 | | P785551 | P776008 | | | P016845 | H770089 | Production |
| FRG2 | G150259 | P785590 | X770693 | P785551 | P776008 | | | P016845 | H770089 | Production |
| FHG | G160048 | P182002 | P119372 | P106639 | | P017336 | P111852 | P100789 | H770089 | Production |
| FHG | G160057 | P182002 | | P106621 | | P017336 | P111852 | H000351 | H770089 | Cancelled |
| STG | G160077 - See page 114 | | | | | | | | | Production |
| FHG | G160078 | P182002 | P119372 | P106952 | P103198 | P017336 | P111852 | H000351 | H770089 | Cancelled |
| STG | G160445 - See page 115 | | | | | | | | | Production |
| FHG | G160609 | P182002 | | P106621 | | P017336 | P111852 | H000351 | H770089 | Cancelled |
| STG | G161006 - See page 114 | | | | | | | | | Production |
| STG | G161020 - See page 115 | | | | | | | | | Production |
| FTG | G180011 | P182042 | P128408 | P775715 | P105220 | | P116175 | H770037 | H001053 | Production |
| FTG | G180013 | P182042 | | P775715 | P105220 | | P116175 | H770037 | H001053 | Cancelled |
| FTG | G180014 | P182042 | P128408 | P775715 | P105220 | P105740 | P116175 | H770037 | H001053 | Cancelled |
| FTG | G180015 | P182042 | | P105220 | P105220 | P105740 | P116175 | H770037 | H001053 | Cancelled |
| FTG | G180019 | P182042 | P128408 | P775715 | P105220 | P105740 | P116175 | H770037 | | Cancelled |
| FRG | G180026 | P531988 | P531995 | | P112803 | | | | | Cancelled |
| FRG | G180031 | P781098 | P781102 | P783185 | P105220 | | | H770037 | H001053 | Cancelled |
| FRG | G180033 | P781398 | P781399 | P783185 | P105220 | | | H770037 | H001053 | Cancelled |
| FRG | G180035 | P781098 | P781102 | P783185 | P105220 | | | H770037 | H001053 | Cancelled |
| FRG | G180038 | P781098 | P781102 | P781084 | P105220 | | | H770037 | H001053 | Cancelled |
| FRG2 | G180073 | P785394 | X770688 | P784792 | P105220 | | | H770037 | H001053 | Production |
| FRG2 | G180074 | P785394 | X770688 | P784792 | P105220 | | | H770037 | H001053 | Production |
| FRG2 | G180075 | P785394 | X770688 | P784792 | P105220 | | | H770037 | H001053 | Production |
| FRG2 | G180087 | P786197 | X770683 | P784792 | P105220 | | | H770037 | H001053 | Production |
| SRG | G200008 | | | | | | | | | Replaced by SSG200087 |
| SRG | G200013 | | | | | | | | | Replaced by SSG200086 |
| SSG | G200086 | P608306 | P608305 | P603716 | P103198 | | | | | Production |
| SSG | G200087 | P608306 | P608305 | P603716 | P103198 | | | | | Production |
| SSG | G200088 | P609519 | P609518 | P603716 | P103198 | | | | | Production |
| FTG | G210007 | P182040 | P117781 | | P105220 | | P116175 | H770068 | H770082 | Production |
| FTG | G210010 | P182040 | P117781 | | P105220 | | P116175 | H770068 | H770082 | Production |
| FTG | G210009 | P182040 | P117781 | P777862 | P105220 | | P116175 | H770068 | | Production |
| FTG | G210012 | P182040 | P117781 | P781411 | P105220 | | P116175 | H770068 | | Production |
| SRG | G290000 | | | | | | | | | Replaced by SSG290057 |
| SRG | G290012 | | | | | | | | | Replaced by SSG290053 |
| SRG | G290023 | | | | | | | | | Replaced by SSG290052 |
| SSG | G290052 | P608306 | P608305 | P603716 | P103198 | | | | | Production |
| SSG | G290053 | P608306 | P608305 | P603716 | P103198 | | | | | Production |
| SSG | G290055 | P609519 | P609518 | P603716 | P103198 | | | | | Production |
| SSG | G290057 | P608306 | P608305 | P603716 | P103198 | | | | | Production |
| STB | G770001 | P182039 | P114931 | | | | | | | Cancelled |
| SRG | G772001 | P182040 | P117781 | L015444 | | P105740 | P116175 | | | Production |
| SRG | G772002 | P182038 | P115070 | | | P105740 | P116175 | | | Cancelled |
| SRG | G772003 | P184040 | P136659 | | | | | | | Cancelled |
| SRG | G772004 | P182048 | P120879 | | | | | | | Cancelled |
| SRG | G772006 | P182038 | P115070 | | | | | | | Cancelled |
| SRG | G772901 | P182040 | P117781 | | | | | | | Production |
| SRG | G772902 | P182038 | P115070 | | | P105740 | P116175 | | | Production |
| SRG | G772906 | P182038 | P115070 | | | P105740 | P116175 | | | Production |
| SRG | G772910 | P182038 | P115070 | | | | | | | Cancelled |
| SRG | G772911 | P182040 | P117781 | | | P105740 | P116175 | | | Production |
| SRG | G772912 | P182040 | P117781 | | | P105740 | P116175 | | | Production |

| Part Number | Product Description | | Page Number |
|-------------|---------------------|-------------|-------------|
| B045008 | FKB | Air Cleaner | 50-54 |
| B055006 | FKB | Air Cleaner | 50-54 |
| B065018 | FLB | Air Cleaner | 90-92 |
| B065045 | FKB | Air Cleaner | 50-54 |
| B070005 | EPB | Air Cleaner | 43-48 |
| B080022 | FLB | Air Cleaner | 90-92 |
| B080067 | EPB | Air Cleaner | 43-48 |
| B080080 | XRB | Air Cleaner | 56-59 |
| B085001 | ECB Duralite™ | Air Cleaner | 38-42 |
| B085011 | ECB Duralite™ | Air Cleaner | 38-42 |
| B085046 | ECB Duralite™ | Air Cleaner | 38-42 |
| B085048 | ECB Duralite™ | Air Cleaner | 38-42 |
| B085056 | ECB Duralite™ | Air Cleaner | 38-42 |
| B095437 | SRB | Air Cleaner | 100-103 |
| B100067 | FLB | Air Cleaner | 90-92 |
| B100094 | ECB Duralite™ | Air Cleaner | 38-42 |
| B100120 | ERB | Air Cleaner | 45 |
| B100121 | SRB | Air Cleaner | 100-103 |
| B100126 | ERB2 | Air Cleaner | 43-48 |
| B100127 | XRB | Air Cleaner | 56-59 |
| B105002 | ECB Duralite™ | Air Cleaner | 38-42 |
| B105006 | ECB Duralite™ | Air Cleaner | 38-42 |
| B105012 | ECB Duralite™ | Air Cleaner | 38-42 |
| B110155 | SRB | Air Cleaner | 100-103 |
| B120260 | FLB | Air Cleaner | 90-92 |
| B120376 | ECB Duralite™ | Air Cleaner | 38-42 |
| B120470 | XRB | Air Cleaner | 56-59 |
| B125003 | ECB Duralite™ | Air Cleaner | 38-42 |
| B125005 | ECB Duralite™ | Air Cleaner | 38-42 |
| B125011 | ECB Duralite™ | Air Cleaner | 38-42 |
| B130010 | ERB | Air Cleaner | 45 |
| B130013 | ERB | Air Cleaner | 45 |
| B130046 | SRB | Air Cleaner | 100-103 |
| B130048 | SPB2 | Air Cleaner | 97-99 |
| B130057 | ERB2 | Air Cleaner | 43-48 |
| B130058 | ERB2 | Air Cleaner | 43-48 |
| B130060 | SPB2 | Air Cleaner | 97-99 |
| B150025 | ERB | Air Cleaner | 45 |
| B150028 | ERB | Air Cleaner | 45 |
| B150058 | ERB2 | Air Cleaner | 43-48 |
| B150059 | ERB2 | Air Cleaner | 43-48 |
| B180011 | ERB | Air Cleaner | 45 |
| B180012 | ERB | Air Cleaner | 45 |
| B180016 | ERB2 | Air Cleaner | 43-48 |
| B180017 | ERB2 | Air Cleaner | 43-48 |
| C045001 | ECC Duralite™ | Air Cleaner | 38-42 |
| C045002 | ECC Duralite™ | Air Cleaner | 38-42 |
| C055002 | ECC Duralite™ | Air Cleaner | 38-42 |
| C055003 | ECC Duralite™ | Air Cleaner | 38-42 |
| C055008 | ECC Duralite™ | Air Cleaner | 38-42 |
| C065001 | ECC Duralite™ | Air Cleaner | 38-42 |
| C065002 | ECC Duralite™ | Air Cleaner | 38-42 |
| C065003 | ECC Duralite™ | Air Cleaner | 38-42 |
| C065004 | ECC Duralite™ | Air Cleaner | 38-42 |
| C065015 | ECC Duralite™ | Air Cleaner | 38-42 |
| C085001 | ECC Duralite™ | Air Cleaner | 38-42 |
| C085002 | ECC Duralite™ | Air Cleaner | 38-42 |
| C085003 | ECC Duralite™ | Air Cleaner | 38-42 |
| C085004 | ECC Duralite™ | Air Cleaner | 38-42 |
| C085005 | ECC Duralite™ | Air Cleaner | 38-42 |
| C085006 | ECC Duralite™ | Air Cleaner | 38-42 |
| C105003 | ECC Duralite™ | Air Cleaner | 38-42 |

| Part Number | Product Description | | Page Number |
|-------------|---------------------|---------------|-------------|
| C105004 | ECC Duralite™ | Air Cleaner | 38-42 |
| C125003 | ECC Duralite™ | Air Cleaner | 38-42 |
| C125004 | ECC Duralite™ | Air Cleaner | 38-42 |
| D045003 | ECD Duralite™ | Air Cleaner | 38-42 |
| D045004 | ECD Duralite™ | Air Cleaner | 38-42 |
| D055004 | ECD Duralite™ | Air Cleaner | 38-42 |
| D065003 | ECD Duralite™ | Air Cleaner | 38-42 |
| D065008 | ECD Duralite™ | Air Cleaner | 38-42 |
| D080020 | PSD PowerCore® | Air Cleaner | 27 |
| D080026 | PSD PowerCore® | Air Cleaner | 27 |
| D080069 | PSD PowerCore® | Air Cleaner | 19-35 |
| D080070 | PSD PowerCore® | Air Cleaner | 19-35 |
| D085011 | ECD Duralite™ | Air Cleaner | 38-42 |
| D085012 | ECD Duralite™ | Air Cleaner | 38-42 |
| D090019 | PSD PowerCore® | Air Cleaner | 27 |
| D090020 | PSD PowerCore® | Air Cleaner | 27 |
| D090021 | PSD PowerCore® | Air Cleaner | 27 |
| D090022 | PSD PowerCore® | Air Cleaner | 27 |
| D090073 | PSD PowerCore® | Air Cleaner | 19-35 |
| D090074 | PSD PowerCore® | Air Cleaner | 19-35 |
| D090086 | PSD PowerCore® | Air Cleaner | 19-35 |
| D090087 | PSD PowerCore® | Air Cleaner | 19-35 |
| D090088 | PSD PowerCore® | Air Cleaner | 19-35 |
| D090089 | PSD PowerCore® | Air Cleaner | 19-35 |
| D090090 | PSD PowerCore® | Air Cleaner | 19-35 |
| D090091 | PSD PowerCore® | Air Cleaner | 19-35 |
| D090098 | PSD PowerCore® | Air Cleaner | 19-35 |
| D090099 | PSD PowerCore® | Air Cleaner | 19-35 |
| D090100 | PSD PowerCore® | Air Cleaner | 19-35 |
| D090101 | PSD PowerCore® | Air Cleaner | 19-35 |
| D100029 | PSD PowerCore® | Air Cleaner | 19-35 |
| D100030 | PSD PowerCore® | Air Cleaner | 19-35 |
| D100031 | PSD PowerCore® | Air Cleaner | 19-35 |
| D100032 | PSD PowerCore® | Air Cleaner | 19-35 |
| D100121 | PSD PowerCore® | Air Cleaner | 19-35 |
| D100122 | PSD PowerCore® | Air Cleaner | 19-35 |
| D100123 | PSD PowerCore® | Air Cleaner | 19-35 |
| D100124 | PSD PowerCore® | Air Cleaner | 19-35 |
| D120035 | PSD PowerCore® | Air Cleaner | 19-35 |
| D120036 | PSD PowerCore® | Air Cleaner | 19-35 |
| D120037 | PSD PowerCore® | Air Cleaner | 19-35 |
| D120038 | PSD PowerCore® | Air Cleaner | 19-35 |
| D125004 | ECD Duralite™ | Air Cleaner | 38-42 |
| E500206 | Metal | Mounting Band | 129 |
| G042546 | FPG | Air Cleaner | 64-69 |
| G042575 | FPG | Air Cleaner | 64-69 |
| G057502 | FPG | Air Cleaner | 64-69 |
| G057504 | FPG | Air Cleaner | 64-69 |
| G057505 | FPG | Air Cleaner | 64-69 |
| G065497 | FPG Alexin™ | Air Cleaner | 70-76 |
| G065498 | FPG Alexin™ | Air Cleaner | 70-76 |
| G065499 | FPG Alexin™ | Air Cleaner | 70-76 |
| G065500 | FPG Alexin™ | Air Cleaner | 70-76 |
| G070006 | FPG | Air Cleaner | 64-69 |
| G070009 | FPG | Air Cleaner | 64-69 |
| G070059 | FPG | Air Cleaner | 64-69 |
| G070060 | FPG | Air Cleaner | 64-69 |
| G082503 | FPG | Air Cleaner | 64-69 |
| G082505 | FPG | Air Cleaner | 64-69 |
| G082508 | FPG | Air Cleaner | 64-69 |
| G082580 | FPG Alexin™ | Air Cleaner | 70-76 |

| Part Number | Product Description | | Page Number |
|-------------|-----------------------|-------------|-------------|
| G082581 | FPG Alexin™ | Air Cleaner | 70-76 |
| G082582 | FPG Alexin™ | Air Cleaner | 70-76 |
| G082583 | FPG Alexin™ | Air Cleaner | 70-76 |
| G090219 | FPG Alexin™ | Air Cleaner | 70-76 |
| G090220 | FPG Alexin™ | Air Cleaner | 70-76 |
| G090225 | FPG Alexin™ | Air Cleaner | 70-76 |
| G090226 | FPG Alexin™ | Air Cleaner | 70-76 |
| G100274 | FPG | Air Cleaner | 64-69 |
| G100275 | FPG | Air Cleaner | 64-69 |
| G100280 | FPG | Air Cleaner | 64-69 |
| G100281 | FRG | Air Cleaner | 83 |
| G100284 | FRG | Air Cleaner | 83 |
| G100317 | FPG Alexin™ | Air Cleaner | 70-76 |
| G100318 | FPG Alexin™ | Air Cleaner | 70-76 |
| G100319 | FPG Alexin™ | Air Cleaner | 70-76 |
| G100320 | FPG Alexin™ | Air Cleaner | 70-76 |
| G100420 | FRG2 | Air Cleaner | 82-88 |
| G100428 | FRG2 | Air Cleaner | 82-88 |
| G110211 | FRG | Air Cleaner | 83 |
| G110269 | FRG | Air Cleaner | 83 |
| G110381 | FRG2 | Air Cleaner | 82-88 |
| G110382 | FRG2 | Air Cleaner | 82-88 |
| G120332 | STG | Air Cleaner | 111-117 |
| G130061 | FRG | Air Cleaner | 83 |
| G130087 | FRG | Air Cleaner | 83 |
| G130088 | FRG | Air Cleaner | 83 |
| G130113 | FRG | Air Cleaner | 83 |
| G130120 | FRG | Air Cleaner | 83 |
| G130232 | FRG2 | Air Cleaner | 82-88 |
| G130233 | FRG2 | Air Cleaner | 82-88 |
| G130234 | FRG2 | Air Cleaner | 82-88 |
| G130235 | FRG2 | Air Cleaner | 82-88 |
| G130236 | FRG2 | Air Cleaner | 82-88 |
| G140076 | STG | Air Cleaner | 80-83 |
| G140445 | STG | Air Cleaner | 111-117 |
| G140076 | STG | Air Cleaner | 111-117 |
| G140077 | STG | Air Cleaner | 80-83 |
| G150092 | FRG | Air Cleaner | 83 |
| G150097 | FRG | Air Cleaner | 83 |
| G150112 | FRG | Air Cleaner | 83 |
| G150255 | FRG2 | Air Cleaner | 82-88 |
| G150256 | FRG2 | Air Cleaner | 82-88 |
| G150259 | FRG2 | Air Cleaner | 82-88 |
| G160077 | STG | Air Cleaner | 111-117 |
| G160445 | STG | Air Cleaner | 111-117 |
| G161006 | STG | Air Cleaner | 111-117 |
| G161020 | STG | Air Cleaner | 111-117 |
| G180031 | FRG | Air Cleaner | 83 |
| G180033 | FRG | Air Cleaner | 83 |
| G180035 | FRG | Air Cleaner | 83 |
| G180038 | FRG | Air Cleaner | 83 |
| G180073 | FRG2 | Air Cleaner | 82-88 |
| G180074 | FRG2 | Air Cleaner | 82-88 |
| G180075 | FRG2 | Air Cleaner | 82-88 |
| G180087 | FRG2 | Air Cleaner | 82-88 |
| G200008 | SRG Axial Seal, Metal | Air Cleaner | 76-79 |
| G200013 | SRG Axial Seal, Metal | Air Cleaner | 76-79 |
| G200086 | SSG | Air Cleaner | 104-110 |
| G200087 | SSG | Air Cleaner | 104-110 |
| G200088 | SSG | Air Cleaner | 104-110 |
| G210007 | FTG | Air Cleaner | 78-81 |

| Part Number | Product Description | | Page Number |
|-------------|--------------------------|-------------|---------------|
| G210010 | FTG | Air Cleaner | 78-81 |
| G290000 | SRG Axial Seal, Metal | Air Cleaner | 76-79 |
| G290012 | SRG Axial Seal, Metal | Air Cleaner | 76-79 |
| G290023 | SRG Axial Seal, Metal | Air Cleaner | 76-79 |
| G290052 | SSG | Air Cleaner | 104-110 |
| G290053 | SSG | Air Cleaner | 104-110 |
| G290055 | SSG | Air Cleaner | 104-110 |
| G290057 | SSG | Air Cleaner | 104-110 |
| H000349 | Metal Mounting Band | | 90, 115, 129 |
| H000350 | Metal Mounting Band | | 114, 115, 129 |
| H000351 | Metal Mounting Band | | 114, 115, 129 |
| H000606 | STG Air Inlet Hood | | 115 |
| H000820 | PBH Full-View | Pre-Cleaner | 131 |
| H000821 | PBH Full-View | Pre-Cleaner | 131 |
| H000822 | PBH Full-View | Pre-Cleaner | 131 |
| H000823 | PBH Full-View | Pre-Cleaner | 60, 131 |
| H000875 | In-Line Separators | | 127 |
| H000878 | In-Line Separators | | 127 |
| H000886 | In-Line Separators | | 127 |
| H000896 | PCH | Pre-Cleaner | 95 |
| H000975 | PCH | Pre-Cleaner | 95 |
| H001032 | Standard | Ejector | 125 |
| H001033 | Standard | Ejector | 125 |
| H001034 | Standard | Ejector | 125 |
| H001035 | Standard | Ejector | 125 |
| H001039 | Standard | Ejector | 125 |
| H001053 | | Rain Cap | 84, 134 |
| H001148 | PCH | Pre-Cleaner | 95 |
| H001212 | PLH Donaspin™ | Pre-Cleaner | 93, 130 |
| H001215 | PLH Donaspin™ | Pre-Cleaner | 93, 130 |
| H001220 | In-Line Separators | | 127 |
| H001249 | PBH Full-View | Pre-Cleaner | 60, 131 |
| H001250 | PBH Full-View | Pre-Cleaner | 131 |
| H001251 | PBH Full-View | Pre-Cleaner | 131 |
| H001277 | Compact Style | Ejector | 125 |
| H001278 | Compact Style | Ejector | 125 |
| H001279 | Compact Style | Ejector | 125 |
| H001280 | Compact Style | Ejector | 125 |
| H001281 | Compact Style | Ejector | 125 |
| H001282 | Compact Style | Ejector | 125 |
| H001283 | Compact Style | Ejector | 125 |
| H001284 | Compact Style | Ejector | 125 |
| H001307 | PLH Donaspin™ | Pre-Cleaner | 93, 130 |
| H001308 | PLH Donaspin™ | Pre-Cleaner | 130 |
| H001375 | PLH Donaspin™ | Pre-Cleaner | 130 |
| H001377 | | Rain Cap | 67, 134 |
| H001378 | | Rain Cap | 73, 134 |
| H001379 | | Rain Cap | 44, 67, 134 |
| H001474 | In-Line Separators | | 127 |
| H001510 | PCH | Pre-Cleaner | 95 |
| H001906 | In-Line Separators | | 127 |
| H002040 | PBH Full-View | Pre-Cleaner | 131 |
| H002041 | PBH Full-View | Pre-Cleaner | 131 |
| H002042 | PBH Full-View | Pre-Cleaner | 131 |
| H002043 | PBH Full-View | Pre-Cleaner | 131 |
| H002129 | Expanded Inlet End Style | Ejector | 125 |
| H002132 | Expanded Inlet End Style | Ejector | 125 |
| H002223 | PBH Full-View | Pre-Cleaner | 131 |
| H002224 | PBH Full-View | Pre-Cleaner | 60, 131 |
| H002394 | PTH TopSpin™ | Pre-Cleaner | 133 |
| H002425 | PTH TopSpin™ | Pre-Cleaner | 133 |

| Part Number | Product Description | Page Number |
|-------------|-----------------------------|----------------------|
| H002426 | PTH TopSpin™ Pre-Cleaner | 62, 133 |
| H002427 | PTH TopSpin™ Pre-Cleaner | 62, 133 |
| H002431 | PTH TopSpin™ Pre-Cleaner | 133 |
| H002432 | PTH TopSpin™ Pre-Cleaner | 133 |
| H002433 | PTH TopSpin™ Pre-Cleaner | 133 |
| H002434 | PTH TopSpin™ Pre-Cleaner | 133 |
| H002435 | PTH TopSpin™ Pre-Cleaner | 133 |
| H002436 | PTH TopSpin™ Pre-Cleaner | 133 |
| H002437 | PTH TopSpin™ Pre-Cleaner | 62, 133 |
| H002438 | PTH TopSpin™ Pre-Cleaner | 133 |
| H002439 | PTH TopSpin™ Pre-Cleaner | 62, 133 |
| H770010 | Rain Cap | 44, 67, 73, 134 |
| H770011 | Rain Cap | 134 |
| H770012 | Rain Cap | 45, 73, 84, 134 |
| H770013 | Rain Cap | 84, 134 |
| H770025 | Metal Mounting Band | 129 |
| H770037 | Metal Mounting Band | 45, 84, 129 |
| H770059 | Metal Mounting Band | 129 |
| H770065 | Metal Mounting Band | 129 |
| H770066 | Rain Cap | 67, 134 |
| H770068 | Metal Mounting Band | 79, 129 |
| H770081 | Rain Cap | 134 |
| H770082 | Rain Cap | 45, 79, 134 |
| H770089 | Rain Cap | 45, 84, 134 |
| H770090 | Rain Cap | 84, 134 |
| P002348 | Metal Mounting Band | 129 |
| P002351 | Metal Mounting Band | 129 |
| P004055 | Metal Mounting Band | 129 |
| P004073 | Metal Mounting Band | 101, 129 |
| P004076 | Metal Mounting Band | 45, 84, 90, 101, 129 |
| P004079 | Metal Mounting Band | 84, 101, 129 |
| P004307 | Metal Mounting Band | 90, 129 |
| P004906 | Metal Mounting Band | 129 |
| P007191 | Metal Mounting Band | 90, 129 |
| P013722 | Metal Mounting Band | 45, 84, 101, 129 |
| P016330 | Bowl Full-View Pre-Cleaner | 131 |
| P016548 | Cover Full-View Pre-Cleaner | 131 |
| P016845 | Metal Mounting Band | 45, 84, 129 |
| P016972 | STG Gasket, Cover | 114, 115 |
| P017281 | SSG20/29 Cover Chain | 107, 108 |
| P017283 | SSG20/29 Chain Connector | 107, 108 |
| P017335 | STG Gasket, Body or Cup | 114, 115 |
| P017336 | STG Gasket, Body or Cup | 114, 115 |
| P017365 | STG Gasket, Cover | 115 |
| P017367 | STG Gasket, Cover | 114, 115 |
| P017617 | STG Cover Latch Assembly | 114, 115 |
| P017804 | SSG20/29 Dust Cup Gasket | 107, 108 |
| P020115 | Bowl Full-View Pre-Cleaner | 131 |
| P020116 | Cover Full-View Pre-Cleaner | 131 |
| P020227 | Bowl Full-View Pre-Cleaner | 131 |
| P020344 | Bowl Full-View Pre-Cleaner | 131 |
| P020345 | Cover Full-View Pre-Cleaner | 131 |
| P020648 | Cover Full-View Pre-Cleaner | 131 |
| P100780 | STG Clamp, Body | 114 |
| P100789 | STG Clamp, Cup | 114 |
| P100794 | STG Dust Cup | 114, 115 |
| P100808 | SSG20/29 Dust Cup Clamp | 107, 108 |
| P100860 | STG Dust Cup | 114, 115 |
| P100866 | STG Clamp, Cup | 114 |
| P101290 | Hump Reducer | 139 |
| P101291 | Hump Reducer | 139 |

| Part Number | Product Description | Page Number |
|-------------|-------------------------------|---------------|
| P101292 | Hump Reducer | 139 |
| P101293 | Hump Reducer | 139 |
| P101294 | Hump Reducer | 139 |
| P101759 | STG Inlet Shroud - Optional | 114 |
| P101891 | Hump Reducer | 139 |
| P102256 | STG Body, Lower | 114 |
| P102820 | Hump Reducer | 139 |
| P102870 | STG Inlet Shroud - Optional | 114 |
| P102948 | Reducer | 139 |
| P103198 | Vacuator™ Valve | 107, 108, 141 |
| P103516 | Hump Reducer | 139 |
| P103530 | STG Dust Cup, Vac Valve, Horz | 114, 115 |
| P103746 | STG Dust Cup, Vac Valve, Horz | 115 |
| P104087 | Reducer | 139 |
| P104088 | Reducer | 139 |
| P104089 | Reducer | 139 |
| P104090 | Reducer | 139 |
| P104694 | Cover Full-View Pre-Cleaner | 131 |
| P104973 | STG Dust Cup, Vac Valve, Vert | 114, 115 |
| P105016 | STG Dust Cup, Vac Valve, Vert | 115 |
| P105220 | Vacuator™ Valve | 79, 84, 141 |
| P105529 | 90° Elbow | 137 |
| P105530 | 90° Elbow | 137 |
| P105531 | 90° Elbow | 137 |
| P105532 | 90° Elbow | 137 |
| P105533 | 90° Elbow | 137 |
| P105534 | 90° Elbow | 137 |
| P105535 | 90° Elbow | 137 |
| P105536 | 90° Elbow | 137 |
| P105541 | 45° Elbow | 138 |
| P105542 | 45° Elbow | 138 |
| P105543 | 45° Elbow | 138 |
| P105544 | 45° Elbow | 138 |
| P105545 | 45° Elbow | 138 |
| P105546 | 45° Elbow | 138 |
| P105547 | 45° Elbow | 138 |
| P105548 | 45° Elbow | 138 |
| P105608 | Straight Hump | 138 |
| P105609 | Straight Hump | 138 |
| P105610 | Straight Hump | 138 |
| P105611 | Straight Hump | 138 |
| P105612 | Straight Hump | 138 |
| P105613 | Straight Hump | 138 |
| P105740 | FTG, STG Gasket Washer | 78, 114, 115 |
| P106593 | Vacuator™ Valve | 106, 141 |
| P107375 | STG Dust Cup, Quick Release | 115 |
| P107377 | STG Dust Cup, Quick Release | 114, 115 |
| P107844 | 90° Elbow | 137 |
| P109021 | 45° Elbow | 138 |
| P109062 | Wing Nut | 114 |
| P109153 | STG Cover | 114, 115 |
| P109331 | 45° Elbow | 138 |
| P110875 | STG Body, Lower | 115 |
| P111414 | Straight Hump | 138 |
| P112605 | 90° Elbow | 137 |
| P112606 | 45° Elbow | 138 |
| P112607 | Hump Reducer | 139 |
| P112608 | Straight Hump | 138 |
| P112609 | Hump Reducer | 139 |
| P112610 | Hump Reducer | 139 |

| Part Number | Product Description | Page Number |
|-------------|--|---------------|
| P112611 | Hump Reducer | 139 |
| P112803 | Vacuator™ Valve | 26, 141 |
| P113733 | 90° Elbow | 137 |
| P114100 | STG Lower Body | 115 |
| P114313 | 45° Elbow | 138 |
| P114314 | 90° Elbow | 137 |
| P114315 | Hump Reducer | 139 |
| P114316 | 45° Elbow | 138 |
| P114317 | Straight Hump | 138 |
| P114318 | 90° Elbow | 137 |
| P114319 | Straight Hump | 138 |
| P114411 | Reducer | 139 |
| P114412 | Reducer | 139 |
| P114931 | STG Safety Element | 114, 115 |
| P115023 | STG Body, Lower | 114 |
| P115096 | SSG29 Body Gasket Strips - two, long | 108 |
| P115098 | SSG20/29 Body Gasket Strips - two, short | 107, 108 |
| P115110 | SSG29 Lower Body Assembly | 108 |
| P115200 | Lined Hose Clamp | 120, 125, 131 |
| P115201 | Lined Hose Clamp | 120, 131 |
| P115202 | Lined Hose Clamp | 120, 131 |
| P115203 | Lined Hose Clamp | 120, 131 |
| P115204 | High Torque Clamp | 120 |
| P115205 | High Torque Clamp | 120 |
| P115206 | High Torque Clamp | 120 |
| P115207 | High Torque Clamp | 120 |
| P115208 | High Torque Clamp | 120 |
| P115209 | High Torque Clamp | 120 |
| P116175 | FTG Wing Nut | 79 |
| P117724 | 90° Elbow Reducer | 137 |
| P117781 | FTG Safety Element | 79 |
| P117785 | SSG20 Lower Body Assembly | 107 |
| P117791 | SSG20 Body Gasket Strips - two, long | 107 |
| P118552 | SSG29 Lower Body Assembly | 108 |
| P119370 | STG Safety Element | 114, 115 |
| P119371 | STG Safety Element | 114 |
| P119410 | FLB Safety Element | 90 |
| P119874 | SSG20/29 Rain Shroud, Right Side | 107, 108 |
| P119875 | SSG20/29 Rain Shroud, Left Side | 107, 108 |
| P119876 | SSG20 Rain Shroud, Front | 107 |
| P119877 | SSG29 Rain Shroud, Front | 108 |
| P121482 | 90° Elbow Reducer | 137 |
| P123462 | 90° Elbow Reducer | 137 |
| P126530 | Hump Reducer | 139 |
| P128408 | FTG Safety Element | 114, 115 |
| P128990 | 90° Elbow Reducer | 137 |
| P129660 | Hump Reducer | 139 |
| P133138 | FLB Safety Element | 90 |
| P133338 | 45° Elbow Reducer | 138 |
| P133339 | 45° Elbow Reducer | 138 |
| P136494 | Hump Reducer | 139 |
| P138403 | Filter Wing Nut | 90 |
| P143422 | Lined Hose Clamp | 120, 131 |
| P143895 | 90° Elbow Reducer | 137 |
| P148337 | T-Bolt Clamp | 120 |
| P148338 | T-Bolt Clamp | 120 |
| P148339 | T-Bolt Clamp | 120 |
| P148340 | T-Bolt Clamp | 120 |
| P148341 | T-Bolt Clamp | 120 |
| P148342 | T-Bolt Clamp | 120 |
| P148343 | T-Bolt Clamp | 120 |

| Part Number | Product Description | Page Number |
|-------------|--|---------------------|
| P148344 | T-Bolt Clamp | 120 |
| P148345 | T-Bolt Clamp | 120 |
| P148346 | T-Bolt Clamp | 120 |
| P148347 | T-Bolt Clamp | 120 |
| P148348 | T-Bolt Clamp | 120 |
| P148349 | T-Bolt Clamp | 120 |
| P148350 | T-Bolt Clamp | 120 |
| P149099 | Vacuator™ Valve | 106, 141 |
| P158089 | SSG20/29 Dust Cup | 107, 108 |
| P158324 | Bowl Full-View Pre-Cleaner | 131 |
| P158914 | Vacuator™ Valve | 57, 67, 73, 84, 141 |
| P159820 | 90° Elbow Reducer | 137 |
| P171376 | 3-Ply Silicone Scavenge Hose | 125 |
| P171378 | 3-Ply Silicone Scavenge Hose | 125 |
| P171381 | 3-Ply Silicone Scavenge Hose | 125 |
| P181039 | STG Main Element | 114, 115 |
| P181041 | STG Main Element | 114, 115 |
| P181042 | STG Main Element | 114, 115 |
| P181044 | STG Main Element | 115 |
| P182039 | STG Main Element | 114, 115 |
| P182040 | FTG Main Element | 79 |
| P182041 | STG Main Element | 114, 115 |
| P182042 | STG Main Element | 114, 115 |
| P182044 | STG Main Element | 115 |
| P185039 | STG Donaldson Endurance™ Mail Element | 114, 115 |
| P185041 | STG Donaldson Endurance™ Main Element | 114, 115 |
| P185042 | STG Donaldson Endurance™ Main Element | 115 |
| P185044 | STG Donaldson Endurance™ Main Element | 115 |
| P185052 | STG Donaldson Endurance™ Main Element | 114 |
| P185152 | SSG20/29 Donaldson Endurance™ Main Element | 107, 108 |
| P185153 | SSG20/29 Donaldson Endurance™ Main Element | 107, 108 |
| P520882 | Hump Reducer | 139 |
| P520883 | Hump Reducer | 139 |
| P520884 | Hump Reducer | 139 |
| P522958 | Vacuator™ Valve | 67, 73, 114 |
| P525956 | Vacuator™ Valve | 106, 114 |
| P532919 | Lined Hose Clamp | 120 |
| P532920 | Lined Hose Clamp | 120 |
| P532921 | Lined Hose Clamp | 120 |
| P532922 | Lined Hose Clamp | 120 |
| P532923 | Lined Hose Clamp | 120 |
| P532924 | Lined Hose Clamp | 120, 125, 131 |
| P532925 | Constant Torque Clamp | 120 |
| P532926 | Constant Torque Clamp | 120 |
| P532927 | Constant Torque Clamp | 120 |
| P532928 | Constant Torque Clamp | 120 |
| P532929 | Constant Torque Clamp | 120 |
| P532943 | 4-Ply Below | 140 |
| P532944 | 4-Ply Below | 140 |
| P532945 | 4-Ply Below | 140 |
| P532946 | Connector/Sleeve | 140 |
| P532947 | Connector/Sleeve | 140 |
| P532948 | Connector/Sleeve | 140 |
| P532949 | Connector/Sleeve | 140 |
| P532950 | Connector/Sleeve | 140 |
| P532951 | Connector/Sleeve | 140 |
| P532952 | Connector/Sleeve | 140 |
| P532953 | Connector/Sleeve | 140 |
| P532954 | Connector/Sleeve | 140 |
| P532956 | Connector/Sleeve | 140 |
| P532957 | Connector/Sleeve | 140 |

| Part Number | Product Description | Page Number |
|-------------|--|-------------|
| P532958 | Connector/Sleeve | 140 |
| P532959 | Connector/Sleeve | 140 |
| P532960 | Hump Hose Connector | 140 |
| P532961 | Hump Hose Connector | 140 |
| P532962 | Hump Hose Connector | 140 |
| P535396 | FPG Safety Element | 67 |
| P535571 | 4-Ply Below | 140 |
| P535572 | 4-Ply Below | 140 |
| P535573 | 4-Ply Below | 140 |
| P541619 | FPG Cover Assy | 48 |
| P544356 | FPG Cover Assy | 48 |
| P544357 | FPG Cover Assy | 48 |
| P600975 | PSD Safety Element | 26 |
| P601560 | PSD Safety Element | 26 |
| P602427 | FKB04 Safety Element | 52 |
| P603504 | SSG20/29 Body Gasket Strips - two, short | 107, 108 |
| P603505 | SSG20 Lower Body Assembly | 107 |
| P603716 | SSG20/29 Cover | 107, 108 |
| P603729 | FKB04 Safety Element | 52 |
| P604457 | FKB04 Main Element | 52 |
| P605731 | XRБ Cover Assy | 57 |
| P606121 | PSD Safety Element | 26 |
| P606497 | FKB04 Cover Assy | 52 |
| P607557 | PSD Safety Element | 26 |
| P608116 | XRБ Main Element | 57 |
| P608117 | XRБ Cover Assy | 57 |
| P608305 | SSG20/29 Safety Element | 107, 108 |
| P608306 | SSG20/29 Main Element | 107, 108 |
| P608391 | XRБ Safety Element | 57 |
| P608533 | PSD Main Element | 26 |
| P608592 | FKB06 Cover Assy | 52 |
| P608599 | FKB06 Safety Element | 52 |
| P608665 | PSD Main Element | 26 |
| P608666 | PSD Main Element | 26 |
| P608667 | PSD Main Element | 26 |
| P608675 | PSD Main Element | 26 |
| P608676 | PSD Main Element | 26 |
| P608677 | PSD Main Element | 26 |
| P609218 | FKB05 Main Element | 52 |
| P609219 | FKB05 Cover Assy | 52 |
| P609221 | FKB06 Main Element | 52 |
| P609508 | SSG29 Lower Body Assembly | 108 |
| P609518 | SSG20/29 Safety Element | 107, 108 |
| P609519 | SSG20/29 Main Element | 107, 108 |
| P609942 | XRБ Cover Assy | 57 |
| P610776 | SSG20/29 Rain Shroud, Right Side | 107, 108 |
| P610777 | SSG20/29 Rain Shroud, Left Side | 107, 108 |
| P611189 | XRБ Safety Element | 57 |
| P611190 | XRБ Main Element | 57 |
| P611539 | XRБ Main Element | 57 |
| P611540 | XRБ Safety Element | 57 |
| P770207 | FLB Safety Element | 90 |
| P770678 | FLB Safety Element | 90 |
| P771039 | SRB Main Element | 101 |
| P772520 | FLB Main Element | 90 |
| P772530 | FLB Main Element | 90 |
| P772556 | FLB Main Element | 90 |
| P772565 | FLB Main Element | 90 |
| P772578 | FPG Main Element | 67 |
| P772579 | EPB, FPG Main Element | 44, 67 |
| P772580 | EPB, FPG Main Element | 44, 67 |

| Part Number | Product Description | Page Number |
|-------------|---------------------------------|-------------|
| P775228 | 90° Elbow Reducer | 137 |
| P775298 | FPG Safety Element | 67 |
| P775300 | EPB, FPG Safety Element | 44, 67 |
| P775302 | EPB, FPG Safety Element | 44, 67 |
| P775305 | EPB, FPG Cover Assy | 44, 67 |
| P775308 | FPG Safety Element | 67 |
| P775311 | FPG Safety Element | 67 |
| P775569 | Vacuator™ Valve | 67, 84, 114 |
| P775631 | FPG Main Element | 67 |
| P776008 | Vacuator™ Valve | 73, 84, 114 |
| P776343 | Rain Cap | 67, 77 |
| P777151 | Plastic Mounting Band | 67 |
| P777153 | FPG Safety Element | 67 |
| P777279 | SRB Main Element | 101 |
| P777414 | SRB Safety Element | 101 |
| P777588 | FPG Main Element | 67 |
| P777589 | FPG Safety Element | 67 |
| P777592 | FPG Main Element | 67 |
| P777593 | FPG Safety Element | 67 |
| P777639 | FPG Alexin™, SRB Safety Element | 73, 101 |
| P777730 | Plastic Mounting Band | 67, 77 |
| P777731 | Plastic Mounting Band | 44, 67, 77 |
| P777732 | Plastic Mounting Band | 44, 67, 77 |
| P777779 | FPG Safety Element | 67 |
| P777998 | SRB Cover Assy | 101 |
| P778214 | RadialSeal™ Main Element | 27, 61 |
| P778565 | 90° Elbow Reducer | 137 |
| P778758 | EPB, FPG Cover Assy | 44, 67 |
| P778776 | RadialSeal™ Safety Element | 41 |
| P778810 | Plastic Mounting Band | 77 |
| P778901 | Plastic Mounting Band | 77 |
| P778905 | SRB Main Element | 101 |
| P778906 | SRB Safety Element | 101 |
| P780378 | Plastic Mounting Band | 77 |
| P780401 | FPG Alexin™ Cover Assy | 73 |
| P780403 | FPG Alexin™ Cover Assy | 73 |
| P780522 | FPG Alexin™, SRB Main Element | 73, 101 |
| P780523 | FPG Alexin™, SRB Safety Element | 73, 101 |
| P780524 | FPG Alexin™ Cover Assy | 73 |
| P780532 | Plastic Mounting Band | 73, 77 |
| P780578 | FPG Alexin™ Cover Assy | 73 |
| P780580 | Plastic Mounting Band | 77 |
| P780594 | Plastic Mounting Band | 73, 77 |
| P781039 | FPG Alexin™ Main Element | 73 |
| P781124 | SRB Cover Assy | 101 |
| P781509 | 90° Elbow | 137 |
| P781510 | 90° Elbow Reducer | 137 |
| P781511 | Straight Hump | 138 |
| P781831 | Plastic Mounting Band | 77 |
| P782176 | SRB Cover Assy | 101 |
| P782578 | FPG Main Element | 67 |
| P783014 | SRB Cover Assy | 101 |
| P783543 | SPB2 Main Element | 99 |
| P783693 | ERB2, SPB2 Cover Assy | 45, 99 |
| P783746 | PSD Adapter | 26 |
| P783747 | PSD Adapter | 26 |
| P783748 | PSD Adapter | 26 |
| P784019 | PSD Adapter (PP) | 26 |
| P784517 | PSD U-Clip Mounting (x4) | 26 |
| P784790 | PSD Check Valve | 26 |
| P784792 | FRG2 Cover Assy | 84 |

| Part Number | Product Description | | Page Number |
|-------------|--------------------------|----------------------|-------------|
| P784834 | PSD | Adapter (PA) | 26 |
| P784869 | ERB2 | Cover Assy | 45 |
| P784892 | FRG2 | Cover Assy | 84 |
| P784923 | FRG2 | Cover Assy | 84 |
| P784944 | FRG2 | Cover Assy | 84 |
| P784954 | ERB2 | Cover Assy | 45 |
| P785236 | PSD | Cover Assy | 26 |
| P785237 | PSD | Cover Assy | 26 |
| P785388 | ERB2 | Main Element | 45 |
| P785390 | FRG2 | Main Element | 84 |
| P785394 | ERB2, FRG2 | Main Element | 45, 84 |
| P785396 | FRG2 | Main Element | 84 |
| P785398 | FRG2 | Main Element | 84 |
| P785426 | ERB2 | Main Element | 45 |
| P785546 | ERB2 | Cover Assy | 45 |
| P785551 | FRG2 | Cover Assy | 84 |
| P785589 | FRG2 | Main Element | 84 |
| P785590 | FRG2 | Main Element | 84 |
| P785610 | ERB2 | Main Element | 45 |
| P785651 | PSD | Cover Assy | 26 |
| P785978 | PSD | Cover Assy | 26 |
| P786050 | PSD | U-Clip Mounting (x4) | 26 |
| P786197 | FRG2 | Main Element | 84 |
| P786337 | In-Line Check Valve | | 126 |
| P786338 | In-Line Check Valve | | 126 |
| P786339 | In-Line Check Valve | | 126 |
| P786340 | In-Line Check Valve | | 126 |
| P786341 | In-Line Check Valve | | 126 |
| P786342 | In-Line Check Valve | | 126 |
| P786343 | In-Line Check Valve | | 126 |
| P786344 | In-Line Check Valve | | 126 |
| P786345 | In-Line Check Valve | | 126 |
| P786685 | PSD | Adapter | 26 |
| P786778 | PSD | Adapter | 26 |
| P786989 | PSD | Cover Assy | 26 |
| P787281 | PSD | Main Element | 26 |
| P788708 | High Torque Clamp | | 120 |
| P822686 | FPG, FPG Alexin™ | Main Element | 67, 72 |
| P822768 | FPG Alexin™ | Main Element | 73 |
| P822769 | FPG Alexin™ | Safety Element | 73 |
| P828889 | FPG Alexin™ | Main Element | 73 |
| P829333 | FPG Alexin™ | Safety Element | 73 |
| X002250 | Mechanical, ServiSignal™ | Indicator | 136 |
| X002251 | Mechanical, ServiSignal™ | Indicator | 136 |
| X002252 | Mechanical, ServiSignal™ | Indicator | 136 |
| X002254 | Mechanical, ServiSignal™ | Indicator | 136 |
| X002275 | Mechanical, Informer™ | Indicator | 136 |
| X002277 | Mechanical, Informer™ | Indicator | 136 |
| X002278 | Mechanical, Informer™ | Indicator | 136 |
| X003538 | STG Gasket Kit | | 114, 115 |
| X003539 | STG Gasket Kit | | 114, 115 |
| X003691 | Moisture Eliminator | | 128 |
| X004476 | Flat Band SealClamp™ | | 121 |
| X004478 | Flat Band SealClamp™ | | 121 |
| X004480 | Flat Band SealClamp™ | | 121 |
| X004482 | Flat Band SealClamp™ | | 121 |
| X004484 | Flat Band SealClamp™ | | 121 |
| X004536 | Flat Band SealClamp™ | | 121 |
| X004537 | Flat Band SealClamp™ | | 121 |
| X004538 | Flat Band SealClamp™ | | 121 |
| X004539 | Flat Band SealClamp™ | | 121 |
| X004816 | Safety Signal Indicator | | 114 |

| Part Number | Product Description | | Page Number |
|-------------|----------------------------------|-------------------|-------------|
| X004962 | Flat Band SealClamp™ | | 121 |
| X005164 | Preformed SealClamp™ | | 121 |
| X005265 | Preformed SealClamp™ | | 121 |
| X005555 | STG Sprint Clip & Pin | | 114, 115 |
| X005822 | Moisture Skimmer | | 128 |
| X005900 | Moisture Skimmer | | 128 |
| X005901 | Moisture Skimmer | | 128 |
| X005921 | Flat Band / Performed SealClamp™ | | 121 |
| X006202 | Flat Band SealClamp™ | | 121 |
| X006203 | Flat Band SealClamp™ | | 121 |
| X006204 | Flat Band SealClamp™ | | 121 |
| X006561 | Drop Down Tube Extension | | 122 |
| X006562 | Drop Down Tube Extension | | 122 |
| X007057 | Preformed SealClamp™ | | 121 |
| X007784 | Stepped Preformed SealClamp™ | | 121 |
| X007785 | Stepped Preformed SealClamp™ | | 121 |
| X007805 | Stepped Preformed SealClamp™ | | 121 |
| X007824 | Stepped Preformed SealClamp™ | | 121 |
| X007829 | Stepped Preformed SealClamp™ | | 121 |
| X007830 | Stepped Preformed SealClamp™ | | 121 |
| X007831 | Stepped Preformed SealClamp™ | | 121 |
| X007832 | Stepped Preformed SealClamp™ | | 121 |
| X007833 | Stepped Preformed SealClamp™ | | 121 |
| X007834 | Stepped Preformed SealClamp™ | | 121 |
| X770037 | Electrical | Indicator | 136 |
| X770050 | Electrical | Indicator | 136 |
| X770052 | Electrical | Indicator | 136 |
| X770061 | Electrical | Indicator | 136 |
| X770062 | Electrical | Indicator | 136 |
| X770075 | Electrical | Indicator | 136 |
| X770225 | Electrical with AMP Connector | Indicator | 136 |
| X770301 | Electrical with AMP Connector | Indicator | 136 |
| X770316 | Electrical with AMP Connector | Indicator | 136 |
| X770317 | Electrical with AMP Connector | Indicator | 136 |
| X770526 | Electrical with AMP Connector | Indicator | 136 |
| X770683 | FRG2 | Kit (Main+Safety) | 84 |
| X770684 | SPB2 | Kit (Main+Safety) | 99 |
| X770685 | ERB2 | Kit (Main+Safety) | 45 |
| X770686 | ERB2 | Kit (Main+Safety) | 45 |
| X770687 | ERB2 | Kit (Main+Safety) | 45 |
| X770688 | ERB2, FRG2 | Kit (Main+Safety) | 45, 84 |
| X770689 | FRG2 | Kit (Main+Safety) | 84 |
| X770690 | FRG2 | Kit (Main+Safety) | 84 |
| X770691 | FRG2 | Kit (Main+Safety) | 84 |
| X770692 | FRG2 | Kit (Main+Safety) | 84 |
| X770693 | FRG2 | Kit (Main+Safety) | 84 |